

Service Manual

**Diagnostic Ultrasound System
1101**

Valid for systems from serial no. 1824869

May 2002



B-K Medical
A Subsidiary of Analogic Corporation

World Headquarters: Mileparken 34 • DK-2730 Herlev • Denmark
Tel.: +45 4452 8100 • Fax +45 4452 8199 • www.bkmed.com • e-mail: support@bkmed.com

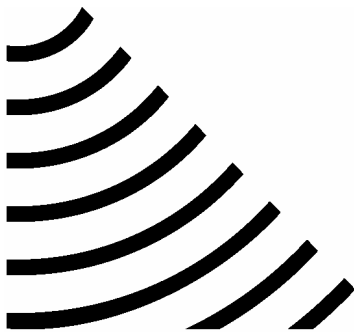

B-K Medical
A Subsidiary of Analogic Corporation

World Headquarters: Mileparken 34 • DK-2730 Herlev • Denmark
Tel.: +45 4452 8100 • Fax +45 4452 8199 • www.bkmed.com • e-mail: support@bkmed.com

1	General Information
2	Service Notes
3	Checking Procedure
4	Trouble Shooting
5	Adjustment Procedure
6	Mechanical Parts
7	Preventative Maintenance
8	Theory of Operation
9	System Interconnections
10	

Section 1

GENERAL INFORMATION

CONTENTS	PAGE
1.1. Safety Aspects	1-2
1.1.1. Terms and Symbols used.....	1-2
1.1.2. WARNINGS and CAUTIONS:.....	1-3
1.2. System Overview	1-4
1.2.1. Front View	1-4
1.2.2. Rear View	1-4
1.2.3. System Configuration	1-5
1.2.4. Modules and PC Boards	1-5
1.3. Revision System	1-5
1.4. Special Tools and Equipment.....	1-6
1.4.1. Checking Procedure (Section 3)	1-6
1.4.2. Troubleshooting (Section 4)	1-6
1.4.3. Adjustment Procedure (Section 5)	1-6
1.4.4. Mechanical Parts (Section 6)	1-6
1.4.5. Preventative Maintenance (Section 7).....	1-7
1.4.6. Electrical Safety Test.....	1-7

1.1. Safety Aspects

The 1101 System complies with IEC 60601-1 safety class I.

The 1101 System is classified as follows:

- Array Input Module: Type B (Body)
- Single-element Transducer Module: Type B (Body)

Note: Some transducers available with the 1101 are however classified as BF. Refer to the attached Safety Test Records in this chapter.

Terms and Symbols used

Throughout this manual the following terms are used to indicate a situation where safety precautions are required:

"WARNING": Indicates a situation involving risk of injury or loss of life to personnel or patient.

"CAUTION": Indicates a situation involving risk of damage to the instrument or other equipment connected.













Symbol	Name	Description
	ATTENTION	Consult ACCOMPANYING User Guide (BB0340) when this sign is encountered on the instrument, to avoid reducing its safety
	Potential Equalisation	Terminal connected to the chassis. Should be connected to corresponding terminals on other equipment to eliminate potential differences.
	Protective Earth	Additional Protective Earth
	Type CF	CF: Isolated from earth. Maximum Patient Leakage Current under: Normal Condition $\leq 10\mu\text{A}$, Single Fault Condition $\leq 50\mu\text{A}$
	Type BF	BF: Isolated from earth. Maximum Patient Leakage Current under: Normal Condition $\leq 100\mu\text{A}$, Single Fault Condition $\leq 500\mu\text{A}$
	Type BF	BF, DEFIBRILLATOR-PROOF
	Type B	B: Maximum Patient Leakage Current under: Normal Condition $\leq 100\mu\text{A}$, Single Fault Condition $\leq 500\mu\text{A}$
IP57	SEALING	Dust and immersion protected according to IEC Publication 529
	Stand-by	Push button for switching the scanner from stand-by to active. (The power supply cord is the means of separation from the main power supply.)
	Off	Main power supply off
	On	Main power supply on
	Non-ionizing radiation	Ultrasound Scanner emits acoustic radiation
	STERILE	Device is in a sterile condition

Table 1. IEC safety symbols

WARNINGS and CAUTIONS:

For your own and others safety please read the following carefully:

Warnings:

- Opening the instrument can expose live parts.
- Any work done on the open instrument with power on must only be done by B-K Medical or their authorised representatives, who are aware of the hazards involved.
- Any repair on the 1101 must be followed by an electrical safety test to verify a continuous safe operation of the system.
- Only the original mains cable must be used
NEVER USE EXTENSION CABLES!!
- The 1101 contains a Lithium battery. Under no circumstances must this battery be removed or replaced by the user as there is danger of explosion.

Personal Safety:

Be aware that there may be a risk of infection due to contaminated equipment, especially puncture guides/needles and transducers. The following precautions should be taken:

At the hospital ask the staff to sterilise transducers and puncture guides before receipt. Consoles must be disinfected as recommended in the User Guide before any repair.

When working with possible infected equipment, use gloves especially if you have open wounds or scratches.

Possible infected equipment must be sterilised before handed over to customers. Follow the recommendations in the Transducer User Guide.

- Always wash your hands after working with the equipment.
- If you scratch yourself on contaminated equipment you should immediately contact the hospital staff or see a doctor.

Cautions:

- Always use correct fuses.
- Switch off all equipment before connecting or disconnecting their interfaces. Failure to do so could damage the equipment.
- The power supply cord is the means of separating the 1101 from the main power supply.

1.2. System Overview

Front View



Fig. 1.2-1. Identify the main parts.

Rear View

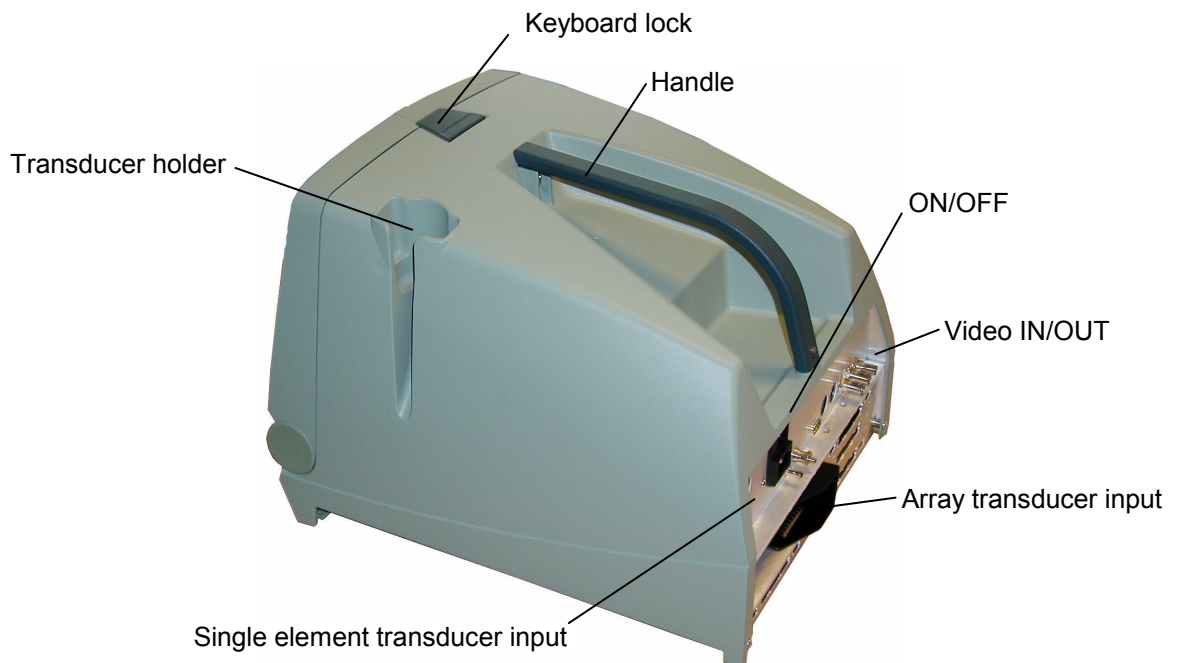

Fig. 1.2-2. Identify the main parts.

System Configuration

The Diagnostic Ultrasound System 1101 is a portable multipurpose ultrasound scanner for B-, and M-mode examinations.

Modules and PC Boards

Part Number	Description
ZE0732	Front End/Delay Board (FE/DLAY)
ZD0761	Core Board
ZH0689	Motherboard
ZH0690	I/O Board
AQ1674	Cable I/O Board - Motherboard
ZV0056	10" Monitor
ZG0342	Power Supply
ZN0023	Fan
NT0256	Track ball
ZH0688	Potentiometer and Gain Board
ZN0014	Keyboard Complete (incl. of NT0256 and ZH0688)
UL0018	Floppy Disk Drive
AQ1673	Cable for Floppy Disk Drive
ZN0020	Single Element Transducer Module (Not available for type 1101-1)

1.3. Revision System

All PC Boards in the 1101 are described by the board name, Type number, Revision code (ID) and PCB Version.

The *name* of the board indicates the *function* of the board, for example the Core Board. The name of the board is changed only if the function of the board changes.

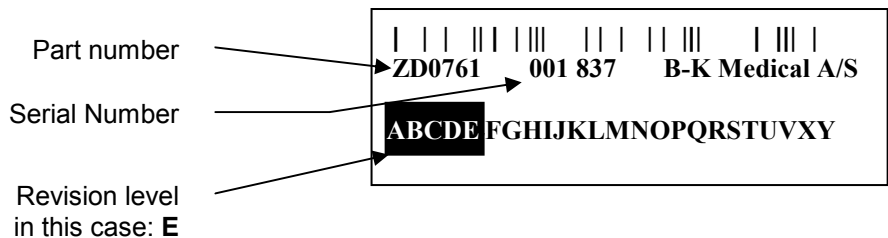

Bar Code Label

The *Part number* of the board, for example ZD0761, is the *order number* of the board. The number is changed if the modification of the existing PCB is found to be too extensive.

The serial number of the board is a unique number used for tracking purposes.

The *revision code* (ABCDEFGH.....) is related to the *modifications* made on the board. The revision letter is marked when modifications are made. When boards are ordered from the B-K Medical stock it is important that the serial number of the scanner is stated. The serial number ensures that the correct revision is shipped.

The PCB version (number e.g. 3) is printed on the circuit board.

1.4. Special Tools and Equipment

The tools and equipment listed below does not include standard tools and commonly used equipment.

Checking Procedure (Section 3)

- Transducer Phantom, model 254 (WQ 0973) for checking a 1101 system equipped with Array- and Single-element Transducers.
- Transducer Phantom, type 251 (WQ 0972) for checking a 1101 system equipped with the Endosonic Probe 1850.
- Ruler (for checking the size of the image on the monitor)
- Floppy disk 3.5" (for testing the floppy disk drive)

Further it is recommended to bring a 150 ml bottle containing preserving fluid for the phantom(s):

Prescription for preserving fluid:

- 94 ml Glycerol (85%)
- 50 ml Rodalon (10%)
- 1000 ml purified Water

Troubleshooting (Section 4)

For troubleshooting the power supply

- DVM

Adjustment Procedure (Section 5)

For adjusting the monitor:

- Nonmagnetic screwdriver
- Ruler (for checking the size of the image on the monitor)

Mechanical Parts (Section 6)

- Static Control Service Kit, type 3M 8501 (WQ 0969) or similar. (when handling the static sensitive PCB's).
- TORX key size 7, 10, and 20.
- Allen key size 2 mm
- Spanner 7 mm

Preventative Maintenance (Section 7)

- Equipment necessary to perform the Preventative Maintenance is the equipment used in the Checking Procedure and Electrical Safety Test.

Electrical Safety Test

- Safety Tester
- HV Tester
- WB 1275 HV test adaptor for type BF Transducers
- WJ 0246 HV Test Plug for Mains
- Electrical Safety Test Record (Enclosed)

This page is left blank intentionally

1101 Electrical Safety Test Record



Equipment under test	Serial no:	Location:
----------------------	------------	-----------

For INSTRUCTIONS read the back of this sheet.

Test Select or	Test		Test Date					Typical value	Test Limits
1	Rigel self test	-						-	-
2	Mains Voltage	-						-	Nominal +/- 10%
5	Pr. gnd	Earth terminal						0,1 ohm	0,2 ohm
5	Pr. gnd	Transducer connector –array						0,1 ohm	0,2 ohm
5	Pr. gnd	Single module connector						0,1 ohm	0,2 ohm
5	Pr. gnd	Monitor						0,1 ohm	0,2 ohm
6	Earth Leakage	Norm.						40 μ A	500 μ A
6	Earth Leakage	Rev.						80 μ A	500 μ A
7	Earth Leakage	Norm.						2 μ A	1000 μ A
7	Earth Leakage	Rev.						120 μ A	1000 μ A
A	2.2 kV (DC)	Mains							No Flash over
Signature									

The test complies with IEC 60601-1 regulations for medical equipment, safety class I, Type B.

Important:

High Voltage testers deliver hazardous currents. Therefore these testers should only be operated by technicians who are aware of the hazards involved.

The complete test must always follow immediately after a repair made on the 1101 Ultrasound Scanner, and always on the fully assembled unit.

Protective GND: General remarks and settings for Test no. 5:

Tester: Rigel 233
Cables: Mains cable for scanner; clip/probe lead (Rigel accessories)
Basic settings: 1101 mains switch ON; Rigel switch settings: Class=I, Type: B
Calibrate Rigel: Connect clip/probe lead between PROBE and GND in IUT POWER socket; Press TEST and zero ohm-meter.

Connect the scanners Main cable from IUT POWER (Rigel) to power inlet on the scanner.

1. Connect the clip/probe lead between PROBE (Rigel) and the left GND connector on the back of the scanner. Press the TEST button and record the resistance. Disconnect the power cable for the monitor.

Note: As the test current is 25 Amps. it is important that the clip/probe lead is held firmly against, or clipped to the GND connector before the TEST button is pressed !

2. Move the clip/probe to the metal the array transducer connector. Press the TEST button and record the resistance.
3. If single module installed: Move the clip/probe to the metal ring on the single module connector. Press the TEST button and record the resistance.
4. Move the clip/probe to on of the metal on the back of the monitor. Press the TEST button and record the resistance.

Leakage Current: General remarks and settings for test no. 6 and 7.

Test 6 measures Earth Leakage current – normal condition

Test 7 measures Earth Leakage current – single Fault Condition (supply open)

Tester: Rigel 233
Cables: Mains cable for scanner;
Basic settings: 1101 mains switch ON; Rigel switch settings: Class = I, Type: B,

1. Connect the mains cable for the scanner to the IUT POWER outlet (Rigel) to power inlet on the scanner
2. Position the Rigel Normal-Reverse switch in *Normal* and record the current.
3. Position the Rigel Normal-Reverse switch in *Reverse* and record the current.
4. Repeat the above test for test no. 7.

High Voltage Test: General remarks and settings for A

Tester: HV Insulation Tester JP15
Cables: HV probe and GND lead (JP15 accessories)
Adaptors: HV test plug for mains WJ0246
Connections: Insert the HV test plug for mains into socket for mains input socket. Connect the JP15 GND with the scanners GND using the JP15 GND lead.
Basic settings: Mains switch on scanner ON; on JP15: Connect HV probe cable with switch plug into socket "HT"/"sw". Select 1µA and 7,5 kV. "Volume" to mid position and HV potentiometer fully anti-clockwise.

Test A: Insert tip of HV probe into the HV test plug for mains. Press button on HV probe handle while increasing the HV to **2.2 kV (DC)** read from the voltmeter. Apply this voltage for **maximum 5 sec.** There must be no flash over nor breakdowns indicated by full deflection on the µA-meter.

1101

Electrical Safety Test Record



Section 2

SERVICE NOTES

Service Notes

To improve the performance of the Merlin scanner 1101, small changes in the hardware and firmware may be made. All information about these changes, and any other change or correction to this Service Manual will be released in the form of Service Informations in the Medical Hotline.

Note

All existing and future Service Notes concerning the 1101 Merlin scanner should be placed in this section.

Edition Number

If any major changes are made to the 1101 Merlin scanner and/or the Service Manual, a new edition will be released.

Any new editions can be recognized by the edition number given in the footer.

The serial numbers from which each edition is valid are listed on the front page.

This page is left blank intentionally

Section 3

CHECKING PROCEDURE

CONTENTS	PAGE
3.1. Introduction	3-2
3.1.1. Necessary Equipment to Perform the Checking Procedure.....	3-2
3.2. Basic Checks	3-2
3.2.1. Visual Inspection	3-2
3.2.2. Keyboard	3-3
3.2.3. Before Power Up	3-3
3.2.4. Power Up.....	3-3
3.2.5. Test Oscillators.....	3-4
3.3. Monitor Checking	3-7
3.4. Transducer Inputs	3-8
3.5. Track Ball	3-8
3.6. Gain/TGC	3-8
3.7. Size	3-8
3.8. Focusing	3-8
3.9. Frame Rate	3-8
3.10. Image Processing	3-9
3.11. Puncture	3-9
3.12. Zoom	3-9
3.13. Measure	3-9
3.14. Image review	3-10
3.15. M-mode	3-10
3.16. Split Screen	3-10
3.17. Image Storage	3-10

Introduction

The Checking Procedure is to verify proper operation of the main functions of the 1101 System.

The procedure should be used during installation, incoming inspection, preventative maintenance and before and after repair.

The procedure is arranged in sections and must be followed from the beginning when performed.

Notes

If the Checking Procedure cannot be performed successfully or if there is a specific fault in the System, refer to Section 4, TROUBLESHOOTING or Section 5, ADJUSTMENT PROCEDURE.

The Checking Procedure does not include a check of the different transducer types.

If in doubt about the functions of the 1101 you should consult the user guide BB0800.

Important!!

Any inside repairs performed on the 1101 must be followed by an Electrical Safety Test.

Necessary Equipment to Perform the Checking Procedure

- Transducer Phantom, model 254 (WQ 0973) for checking a 1101 system equipped with Array- and Single-element Transducers.
- Transducer Phantom, type 251 (WQ 0972) for checking a 1101 system equipped with the Endosonic Probe 1850.
- Ruler (for checking the size of the image on the monitor)
- Floppy disk 3.5" (for testing the floppy disk drive)
- Array Transducer (Linear or Convex).
- Sector Transducer (for systems equipped with Single-element module)

Note:

If a phantom is not available the human body is a good alternative.

Basic Checks

Visual Inspection

1. Check the overall appearance of the 1101.

Especially check for scratches.

Keyboard

1. Check that the keyboard is easy to move up and down.

Before Power Up

1. The 1101 System complies with the IEC 60601-1 safety regulations and as such it **must** be connected to a mains outlet having a safety ground connection. Therefore: Check that the 1101 mains cable is terminated with a three-pole plug that fits a three-pole mains outlet. For safety reasons do not use extension cables!
Note: The 1101 operates from 90 – 270V using the same type fuse VF0007 (T 1.6A H, 250V).

Power Up

1. Disconnect all accessories from the 1101 and connect any transducer available which fits the Array Input Module.
2. Switch On the 1101.
After a few seconds the power up (boot) sequence is completed.
3. Verify that the monitor opening layouts are shown in Fig. 3.3 -1. Note that the menu shown (settings) differs from transducer type.

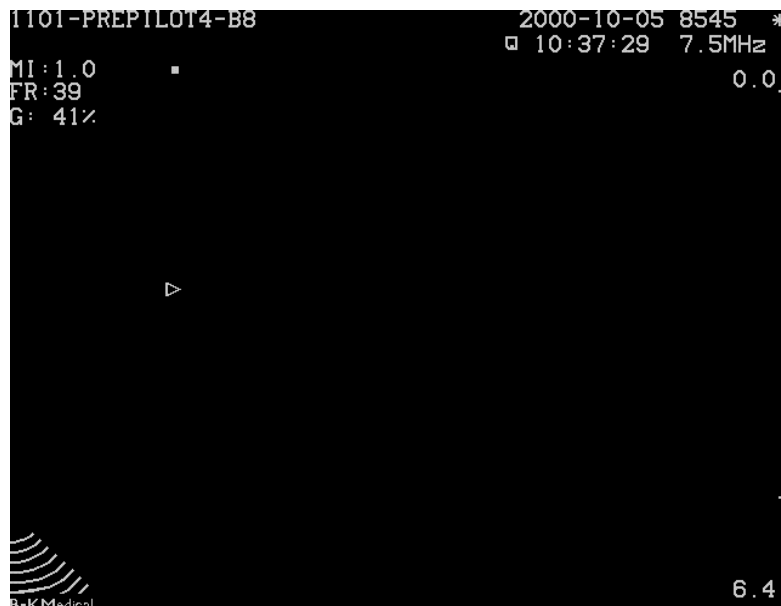

Fig. 3.3-1. The default display.

4. Check that the following is displayed on the monitor:
 - the current date and time
 - a white "Asterisk" ("Freeze"-mode)
 - Transducer type

Note: If the displayed date and time is incorrect, press **Setup** to display the Setup menu where the date and time adjustment is found.

Test Oscillators

1. Connect a transducer to the 1101.
2. Switch On the scanner.
3. Press **Shift, Alt** and **Probe (X)** to select the Test menu
4. Select the Scancon Test oscillator by pressing **F3** and unfreeze
5. Press **Shift, Alt** and **Probe (X)** to access the Test Oscillator again.
6. Toggle between Scancon test 1,2 and 3 by pressing **F3**, and compare to the images below. Note that the actual image on the scanner depends on various settings e.g size.

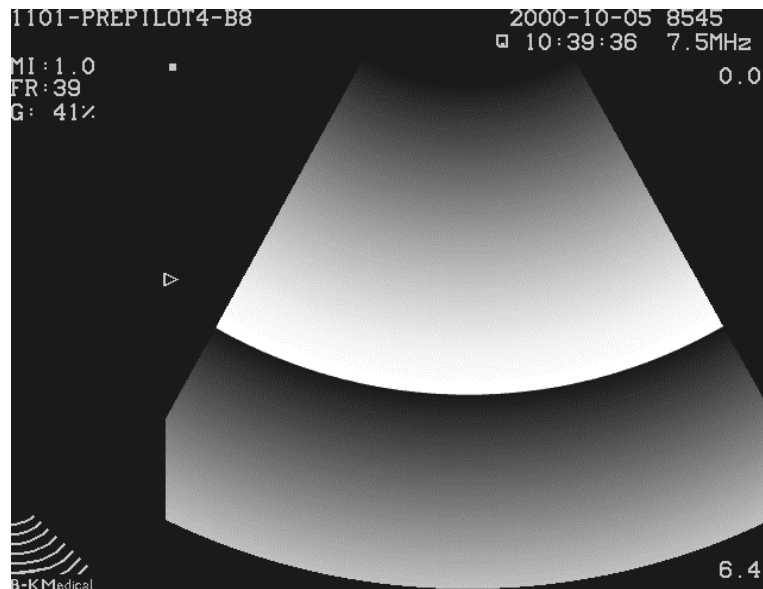

Fig. 3.3-2. Scancon Test Osc. 1 and 2. Check that image is going from black to white

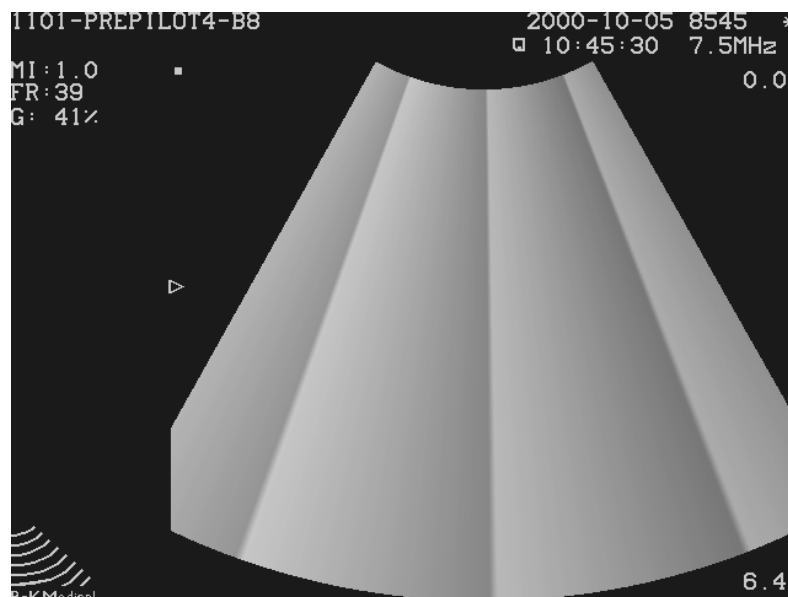

Fig. 3.3-3. Scancon Test Oscillator 3.

7. Exit the Scancon Test by keeping **F3** depressed for 1 second.

8. Select the Input Test Oscillator by pressing **F1**. Compare to the image below.

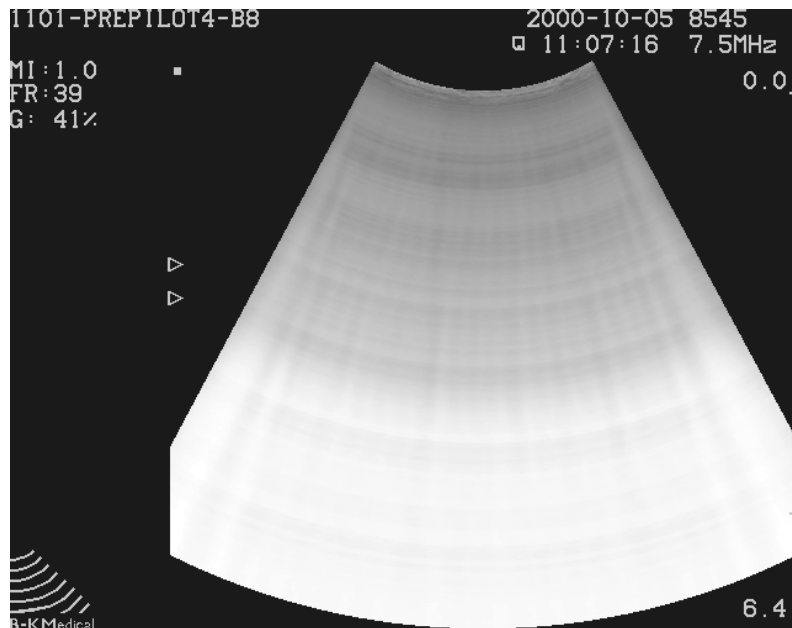

Fig. 3.3-4. Input Test Oscillator.

9. Exit the Input Test Oscillator by pressing **F1**.
10. Switch off the scanner and disconnect all transducers from the 1101.
11. Turn on the scanner and after the boot sequence press **Shift, Alt** and **Probe (X)**
12. Select the Delay Test oscillator by pressing **F2** and unfreeze The image should now look like the figure below i.e. concentric bands which gradually goes from black to white (light grey) and then back to black.
Note ! The actual number of concentric bands depends on the size selected.

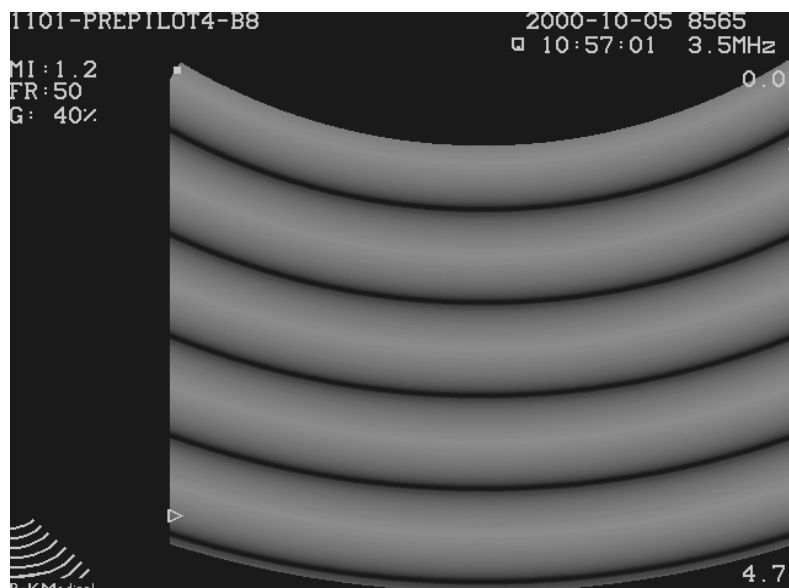

Fig. 3.3-5. Delay Test Oscillator 1

13. Press **Shift, Alt** and **Probe (X)** to access the Test Oscillator again.
14. Press **F2** to start Delay test oscillator 2. The image should now look like the figure below. 4 concentric bands which consist of a number of white (light grey) blocks separated by 32 narrow black radial lines.
15. Turn the gain down to see if all bands can be adjusted to dark grey and turn the gain up again to see if all bands appears white again.

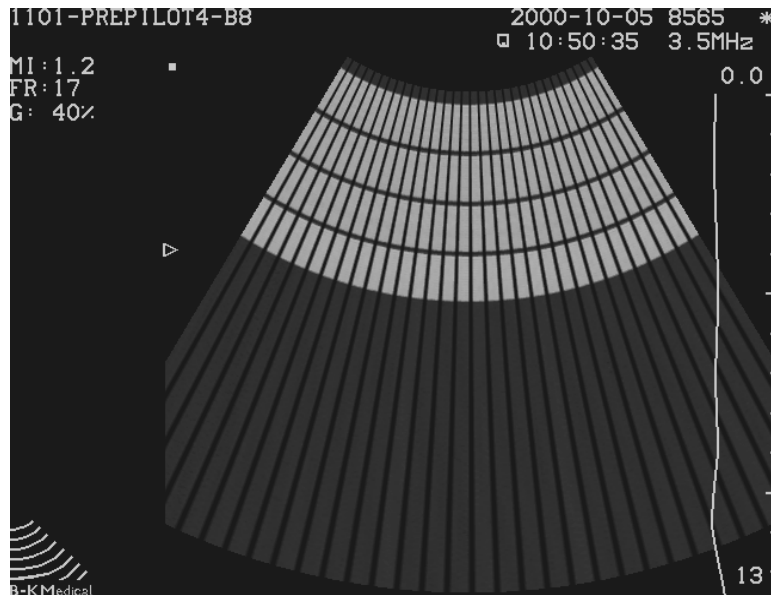

Fig. 3.3-6. Delay Test Oscillator 2.

16. Press **F2** to start Delay test oscillator 3. The image should now look like the figure below i.e. 16 radial fields separated by narrow white lines. The fields should be white from top to bottom and then gradual decrease in length going from right to left.
17. Turn the gain down to see if all fields can be adjusted to dark grey and turn the gain up again to see if all fields appears white again.

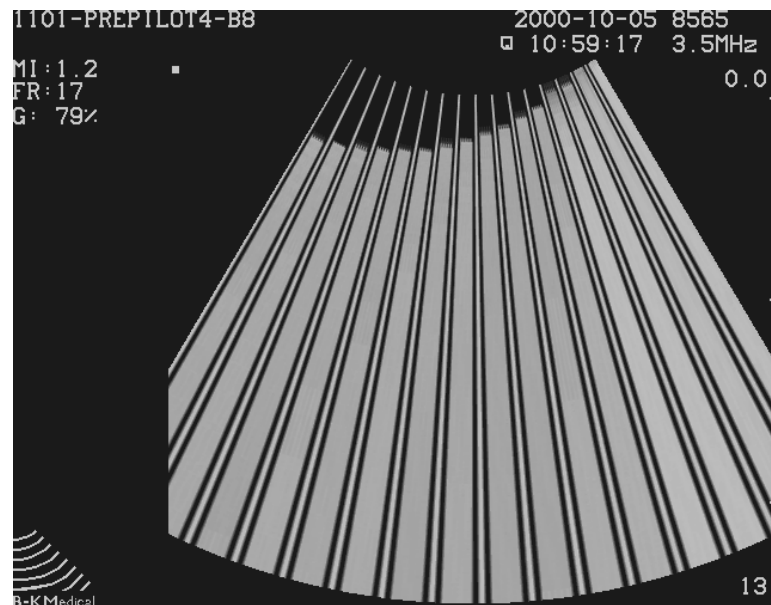

Fig. 3.3-7. Delay Test Oscillator 3.

18. If the 1101 has a single input module then disconnect the transducers.
19. Start the Single Input Test Oscillator by pressing **Shift, Alt, and Z**, select e.g. 8539 (**F2**) and unfreeze. Compare to the image below. Note that it may be necessary to increase the gain to get an image like the one below.

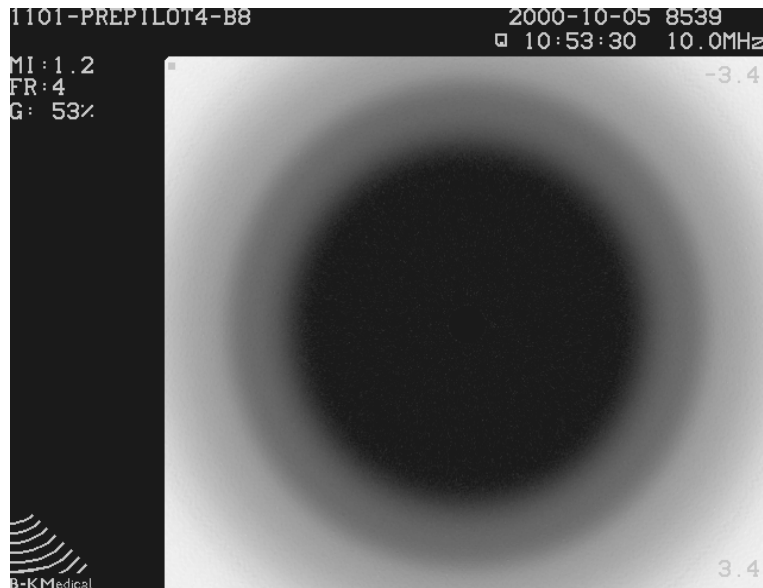

Fig. 3.3-8. Single Input Test Oscillator.

20. Exit the Single Input oscillator by pressing **Shift, Alt, and Z**.

Monitor Checking

1. Press **Shift, Alt, and G**, to get a greyscale on the monitor screen (The scanner must be in freeze mode).
2. Verify that the external controls for Brightness and Contrast (on the monitor) provides sufficient adjustment range and set to give the best image.
3. Press the **Shift, Alt and Probe(X)**. Then press **F5** to chose the Test picture. (Pressing **F5** toggles between Geometric test picture, all pixel off, all pixels on)

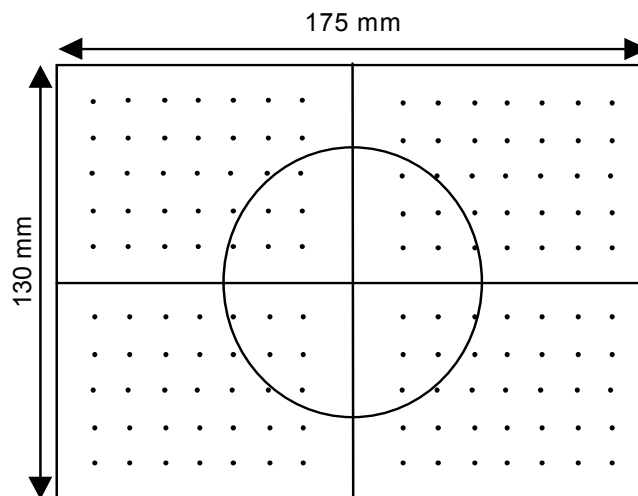

Fig. 3.3-9. The Geometric Test Picture..

4. Check the geometry of the test Picture.
If you have problems meeting the above requirements, consult Section 5, ADJUSTMENT PROCEDURE.

Transducer Inputs

If available connect a Single-element transducer to the Single element socket and verify correct operation of the transducer.

Track Ball

The track ball should move smoothly.

1. Start the scan mode and press .
2. Press **ABC** and check that a white square appears on the monitor screen. Move your finger on the Tracker ball and verify that the square can be set off for a linear movement in any direction within the B-image field.
3. Press **ABC** until the square disappears.

Gain/TGC



1. Press  to start scanning.
2. Adjust the gain using the gain potentiometer and observe the effects on the B-image.
3. Adjust the TGC curve using the TGC Potentiometers and observe the effect on the B-image.

Size

1. Verify the function of the  (Image Size): Press Lower Image Size button to decrease the size of the objects (higher scale units) and the upper Image Size button to enlarge the size of the objects (lower scale units).

Focusing

Note: This section is only valid for array transducers.

1. Check that there is a focus zone mark (arrow) on the screen. (If not press )
2. Move the Tracker Ball up and down and check that the arrow moves accordingly on the monitor screen. Also check that max. lateral (horizontal) resolution is at the position of the arrow - use the phantom, model 254, to check the focusing.
3. Press  again to toggle the number of zones selected (1-4)

Frame Rate



1. Connect a mechanical transducer and press the Frame Rate Up/Down  and observe that the speed of motor change correspondingly.
2. Connect a Array transducer, press the Frame Rate Up/Down and observe that increased frame rate narrows the scanning field.





Image Processing

1. Press . Use phantom, model 254, to check the following:
2. Press Contrast **F1**, **F2** and observe the effect on the image.
3. Press Contour **F3** and observe the effect on the image
4. Press Grey Scale **F4**, and step through the five different gray scales by pressing **F4** successive. Observe the effect on the image
5. Press Persistence **F5** and step through the four different settings by pressing **F5** successive. (4 is max. persistence).

Puncture

1. Press  to select the default puncture guide for the selected transducer, if applicable, and check that puncture dots appear in the B-image field.

Zoom

1. Press  and check that a white frame appears on the screen. (Dependent on the setting in System Setup the frame will have a zoom or panning function)
2. Check by using the tracker ball that the frame can be moved to any position.
3. Press the  control to adjust the size of the zoom frame.
4. Press the  control to be able to move the zoom frame again if necessary.
5. The scanner will automatically zoom in on the selected area when you have finished resizing and moving the frame.
6. To move or resize the zoom area Press , the image is shown in full size, adjust the frame size and location and the scanner will automatically zoom in on the new area.
7. To turn off the Zoom function, press  for more than 1 second.

Measure









1. Freeze the image and press  to place a set of distance markers on the monitor. Check that the distance between the markers are read out.
2. Press  to move the other marker.
3. Activate another set of markers by pressing .
4. Check the Area and Volume determination using the Draw- or Ellipse methods. Press .
5. Press **Draw** or .
6. Press  to start drawing and use the trackball to draw/move the cursor.
7. Press  to stop drawing and check the readout of area and volume (press **Volume** if using the draw function).

Image review

1. Make a scan and press .
2. Observe that a horizontal Track ball movement scrolls through the most recently recorded B mode images.

M-mode

Note: This section is only valid Array transducers.

1. Press the **M** on the keyboard.
2. Start the transducer and check that the echoes now are displayed both as a normal image and as horizontal lines that reflect the echo information along the M-mode line.

Split Screen





1. Press  to activate Split Screen.
2. Press  to make a scan "A"
3. Press  and repeat for "B"

Image Storage

1. Insert a formatted floppy disk in the floppy drive.
2. Freeze the image on the screen.
3. Press **Store** to store the current monitor display on a floppy disk and enter Yes (**F1**) When asked "Patient ID OK?".
4. Press  and press **F5** to see the list of images on the floppy disk and press  to retrieve the image.

Section 4

TROUBLESHOOTING

CONTENTS	PAGE
4.1. Introduction	4-2
4.2. Replaceable Parts	4-2
4.3. Keys to Troubleshoot Specific Problems (Hints)	4-3
4.3.1. Boot Problem	4-3
4.3.2. Loss of use set-up	4-3
4.3.3. Transducer or scanner ?	4-3
4.3.4. No Echo Information	4-4
4.4. The Test Oscillators	4-5
4.4.1. The Scancon Test Oscillators (Core Board).....	4-6
4.4.2. The Delay Test Oscillator (FE/Delay board).....	4-7
4.4.3. The Input Test Oscillator	4-8
4.4.4. The SingleInput Test Oscillator Optional).....	4-9
4.4.5. Monitor Tests	4-9
4.5. Power Supply	4-10
4.5.1. Troubleshooting the Power Supply	4-10
4.5.2. The Voltage LED's.....	4-10
4.5.3. Block Diagram of the Power Supply	4-10
4.5.4. Power Supply Specifications.....	4-12
4.6. Monitor	4-12
4.6.1. Monitor Disassembling	4-12
4.6.2. Missing picture on monitor.....	4-12
4.7. Software update	4-13
4.8. Error Log on Core Board.....	4-14

4.1. Introduction

This section is divided into separate sub-sections some of which cover specific areas within the troubleshooting, others describe the overall test facilities in the 1101.

But before you jump to any of the subsections you should first consult Section 4.3 which might give you, if not the solution, then some ideas of how to troubleshoot this particular problem of yours.

To prevent injury to persons and damage to the 1101 be aware of the following:

WARNINGS:

- Opening the Cabinet can expose live parts.
- Any work done on the open instrument with power On must only be done by B-K Medical or their authorized representatives, who are aware of the hazards involved.
- Any repair work done on the 1101 system must be followed by an electrical safety test to verify a continuous safe operation of the system.
- The Core board contains a lithium battery. The battery must only be replaced by a person having special knowledge as described in sec. 4.2 Replaceable Parts

CAUTIONS:

- Switch Off the 1101 before connecting or disconnecting the 1101 to any peripheral units. Failure to do so could damage the equipment.
- The PC Boards in the 1101 are sensitive for static discharge. Therefore, when handling PC Boards always take steps to prevent static discharge - see Section 1.5, Special Tools and Equipment.

4.2. Replaceable Parts

Apart from a few exceptions listed below all PC Boards and modules in 1101 can be replaced without further actions made. Any work that requires opening the 1101 must however be followed by an electrical safety test.
 Before replacing a subassembly it is necessary to verify that the ID (revision) of the new part is the same or higher than the ID of the defective part.

Item to be replaced:

Necessary action after replacement:

ZV0056 - Monitor
 QB0041 – Lithium battery

Monitor Adjustment - Section 5
 Set real time clock + User settings

4.3. Keys to Troubleshoot Specific Problems (Hints)

Boot Problem

Possible cause	Look for	Actions to locate failure
Defective Power Supply	Green LED inside power supply	Check the Power Supply – sec. 4.5
Dip Switch #8 set to Debug terminal	Only the first line in the boot sequence is displayed	Check dip switch #8 – sec. 9.5
Defective Core board	After “switching task” in the boot sequence the scanner stops (breaks down).	Check error log – sec. 4.8
Defective Core board	The count up in the boot sequence is never completed to “switching task”	Try to reload the software
Defective Keyboard	The message : “Keyboard error ! “ is displayed during boot up	Check the keyboard connection if OK try another keyboard Note: a keyboard from a 2101/2102 can also be used for this test

The boot sequence should under normal circumstances look like below. The first line: “Type 2100 LOADER VP2767 (CB2100) 10-26-2001 08:48:14” appears when the system is starting in the boot-prom.

Then it starts loading the main software from the Flash-prom into the RAM, this is indicated with a number (Byte) counting up.

As the last sequence the task is changed to the main software – “switching task”.

```

Type 2100 LOADER VP2767 (CB2100) 10-26-2001 08:48:14
-----
P /F00 /IO
Loading from prom to ram
Reading data
Id:  Rel_V1.20_CB2100
    04-15-2002 10:51:35
2863956
switching task

```

Fig. 4.3-1. Booting sequence on the monitor screen

Loss of use set-up

Check the lithium battery on the Core board (also check for bad contact)

Transducer or scanner ?

- First of all: Try another transducer!
- If possible, connect a single-element transducer to bypass most of the FE/Delay board.

Radial or Vertical lines

The problem is most likely caused by the FE/Delay, or the transducer. Use the Test Oscillators to isolate the fault. (**Shift, Alt and Probe(X)**)

Concentric rings or Horizontal bands

If concentric rings or horizontal bands are visible in the B-image the FE/Delay board should be suspected. Use the Test Oscillators to isolate the fault. (**Shift, Alt and Probe (X)**)

Noise pattern in the B-image

A noise pattern in the **far field** is often caused by external noise entering the scanner through the air or via the mains cable. To isolate the problem check/try the following:

- Connect the scanner to another mains outlet, preferably in another room. A change in the noise pattern indicates noise on the mains.
- Check that the wall outlet has a proper grounding.
- Compare different transducer types and frequencies (MFI). External noise is often frequency specific.

The noise can also be caused by a failure in the digital noise reduction system on the Delay board. Use the test oscillators to confirm this. (**Shift, Alt and Probe(X)**)

Note:

Before contacting the support group in Denmark for help with noise problems it is recommended that you try out the suggestions above. If installed, use the image storage facility of the 1101 to save a couple of images showing the problems. The images can easily be attached to a e-mail.

No Echo Information

Possible cause	Look for	Actions to locate failure
Defective transducer		Try another transducer
Defective Front End/Delay board - recognize circuit	Transducer type no. on the monitor	Try another transducer and/or try the delay/single module test which simulates the transducer codes
Defective keyboard (* key)	Does * symbol disappear when unfreezing	Try on the scanner keyboard and on the transducer as well
Missing HV on Power Supply	Green HV-LED inside power supply	Check the Power Supply – sec. 4.5
Failure on Front-end/Delay board - receive part		Check input test osc. – sec. 0
Failure on Front-end/Delay board - Delay part		Check delay test osc. – sec. 0
Defective Core board -Scan Converter part		Check scancon test osc - sec 0
Defective Core board – HV setup to Power Supply	Green HV-LED inside power supply	Check the Power Supply – sec. 4.5
Defective Core board – RTSC part		Try with another Core board

4.4. The Test Oscillators

The 1101 is equipped with a number of Test Oscillators for troubleshooting purposes. The Test Oscillator menu are activated by pressing **Shift, Alt and Probe(X)**. The Single Transducer test oscillator are activated by pressing **Shift, Alt, Z**

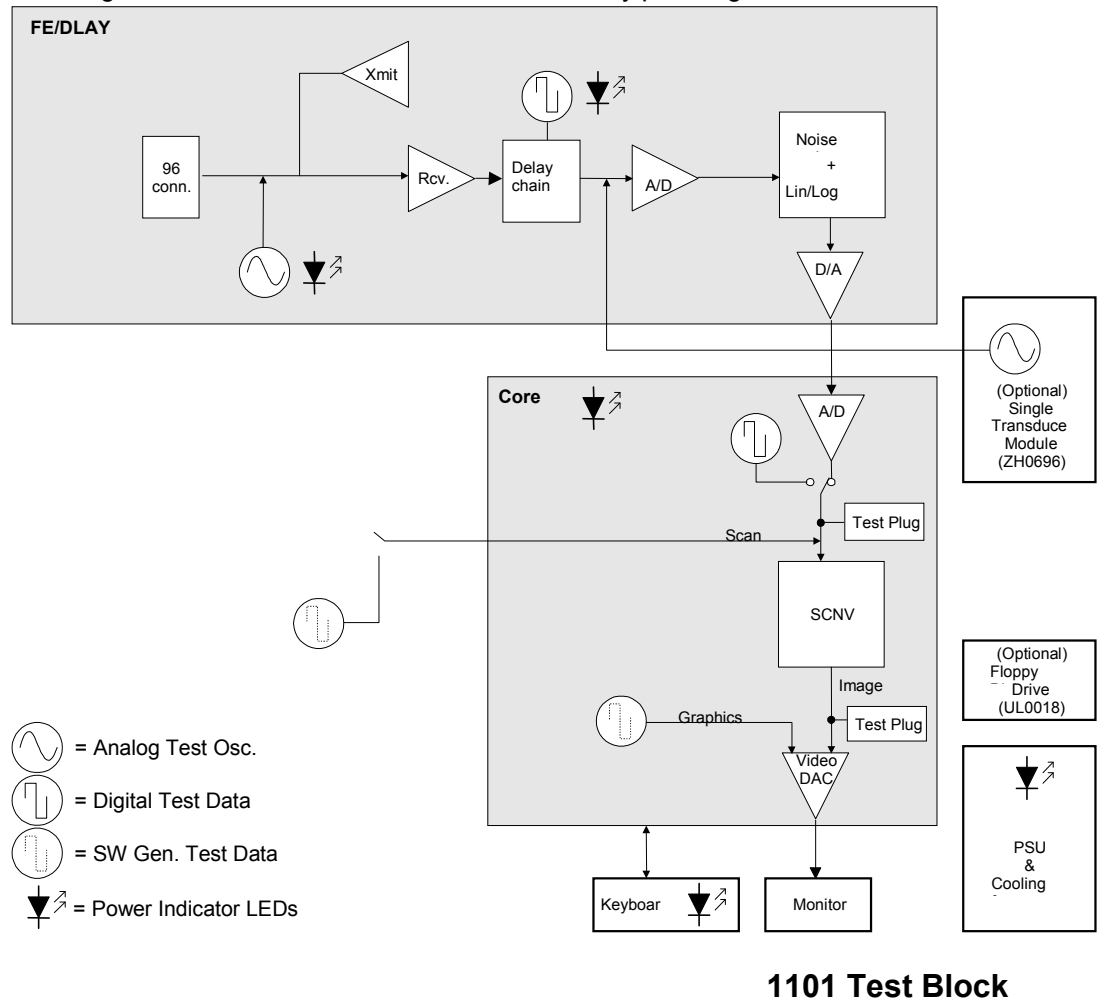

Fig. 4-4-1. Oscillator Signal Flow

The Delay test #2 and #3 uses the Input test oscillator thus the Input test osc. must work in order to start the Delay test osc.

The Delay and Single module test both simulates transducer codes which can be used to isolate failures with recognizing a transducer.

The Scancon Test Oscillators (Core Board)

An array transducer must be connected and active to start this oscillator.
 Press **F3** Scancon osc to toggle between Scancon test 1,2 and 3.

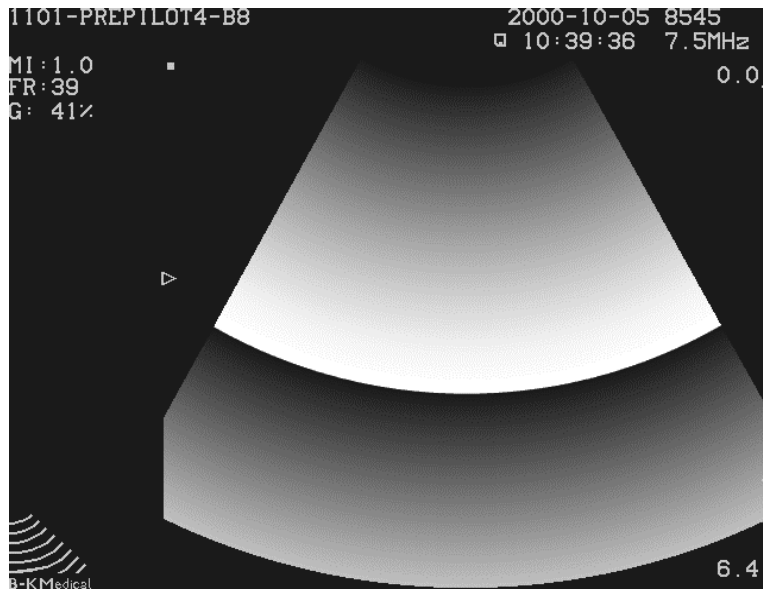

Fig. 4.4- 2. Scancon Test Oscillator 1 and 2

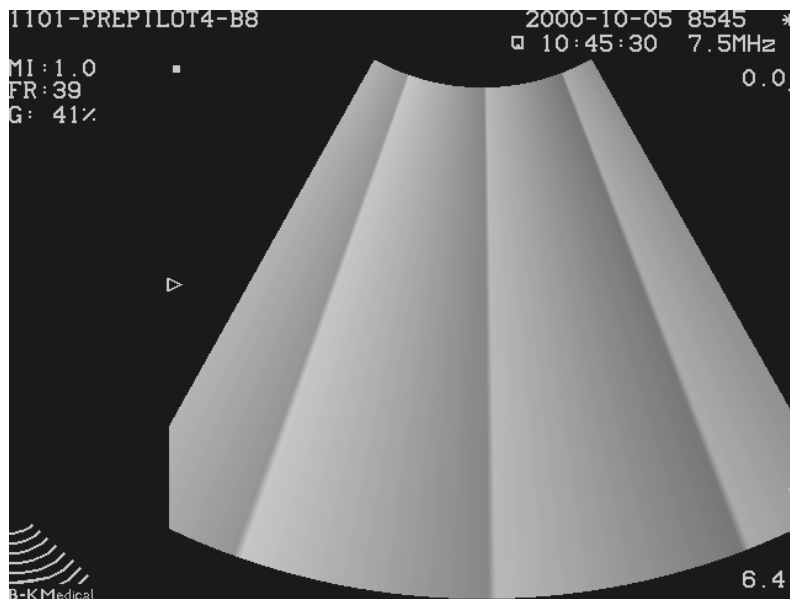

Fig. 4.4- 3. Scancon Test Oscillator 3

The Delay Test Oscillator (FE/Delay board)

Power off, disconnect all transducers and power on the 1101. Press **Shift, Alt** and **Probe(X)**. and then press **F2**, Delay Test to toggle between Delay osc. 1,2 and 3.

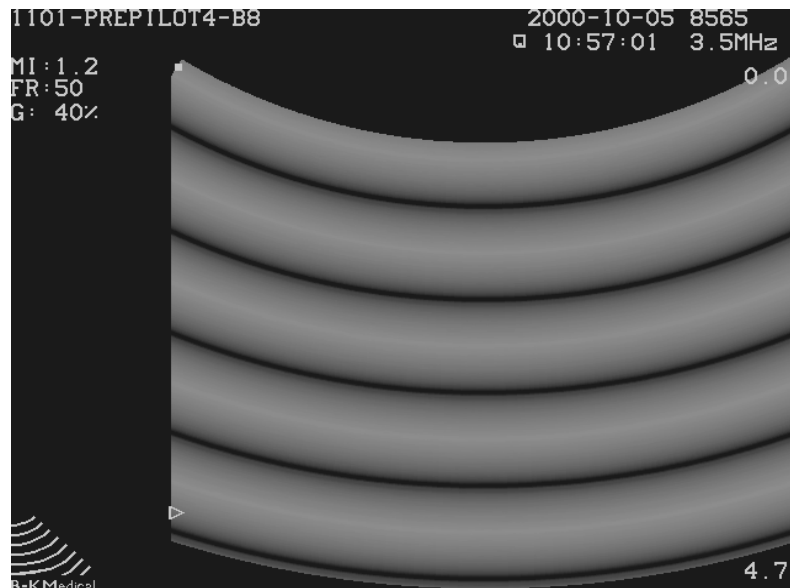

Fig. 4.4- 4. Delay Test Oscillator 1.

The DELAY TEST 1 is a verification of the digital noise reduction. It is controlled that data can be written to the noise reduction frames and that the signal compression is functioning. The image consist of concentric bands which gradually goes from black to white (light grey) and then back to black.

Pre-requisite: The Scancon Test must pass.

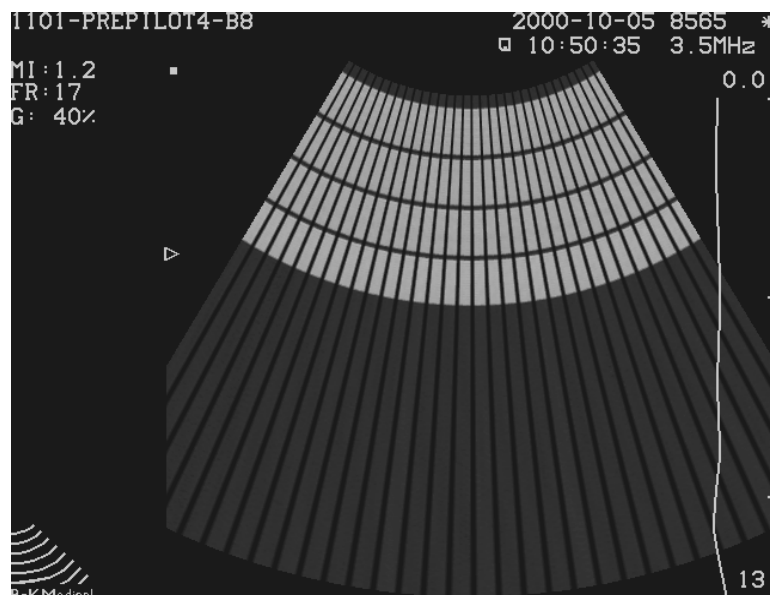

Fig. 4.4- 5. Delay Test Oscillator 2.

DELAY TEST 2 is a verification that all 32 channels from the FE/Delay board are active. Four circular bands are shown, one for each delay component. Each of the rectangles consist of 16 narrow bands. One for each Tap Driver. Note ! If changing size after the test is activated you may only see some of the four bands.

Pre-requisite: Input Test Oscillator and Delay Test 1 must pass

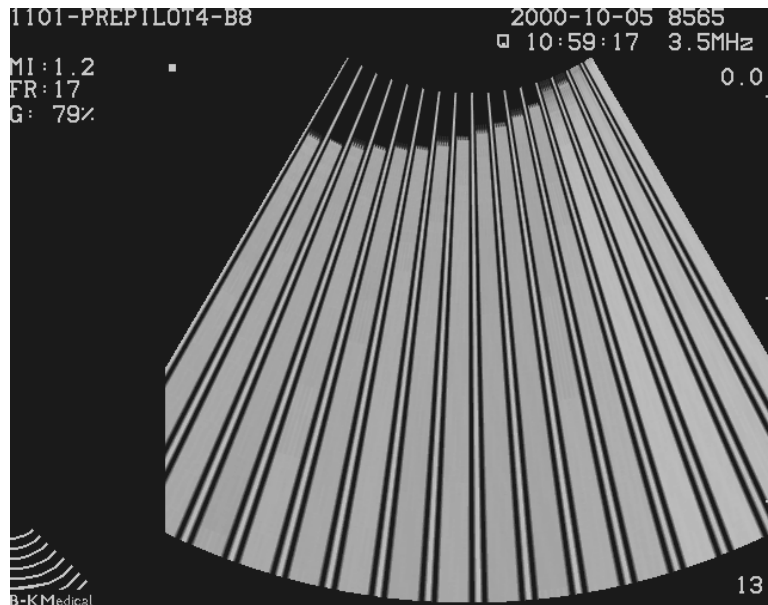

Fig. 4.4- 6. Delay Test Oscillator 3.

DELAY TEST 3 is a verification that all 16 inputs on the beamformer works, including aperture opening and dynamic focusing. The 16 radial fields separated by narrow white lines. The fields should be white from top to bottom and then gradual decrease in length going from right to left.

Pre-requisite: Input Test Oscillator, Delay Test 1 and Delay Test 2 must pass.

The Input Test Oscillator

An array transducer must be connected and active to start this oscillator. Press **F1** to select the Input Test Oscillator.

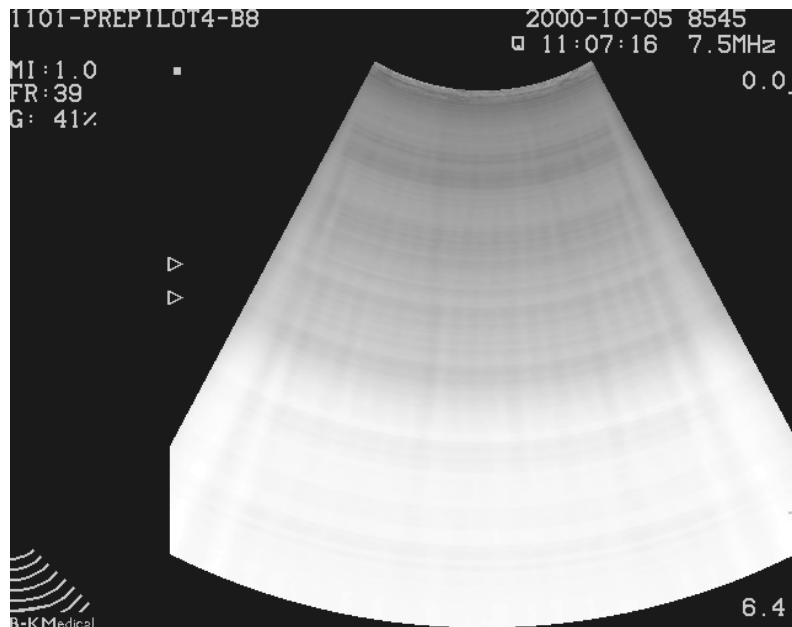

Fig. 4.4- 7. Input Test Oscillator.

The SingleInput Test Oscillator Optional)

Disconnect the transducer before activating the Single Input Test oscillator by pressing **Shift -Alt-Z**. Then select the single element simulator that you want to activate e.g. 8539 – used with 1850 - (F2) and press **⊛**.

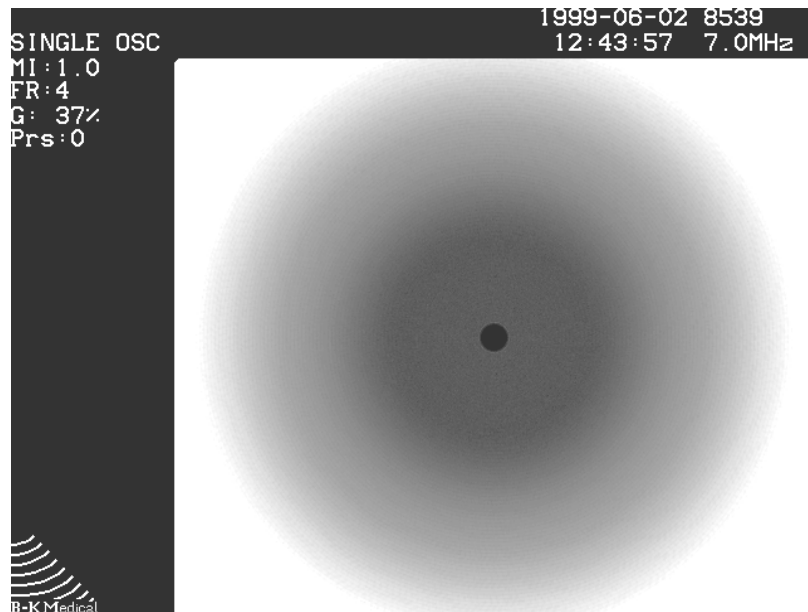

Fig. 4.4- 8. Single Input Test Oscillator.

Monitor Tests

The monitor tests are used during checking and adjustment of the 1101 monitor. To start the Test osc. Press **Shift, Alt** and **Probe(X)**. Press **F5** to toggle between the three test pictures.

1. Geometric Test picture for testing linearity, phase and size.
2. All pixels off.
3. All pixels on.

(See Section 5, MONITOR ADJUSTMENT PROCEDURE.)

4.5. Power Supply

Troubleshooting the Power Supply

The 1101 Power Supply is replaced as a complete unit.

WARNING: Mains voltage is present in the Power Supply.

The Voltage LED's

Inside the Power Supply are two green Voltage LED's which are visible through holes at the power supply cover (when the top cover of the 1101 has been removed). When the Power Supply is working satisfactorily, i.e. all voltages are present, the left hand Green Voltage LEDs will be lit. The right hand LED which represents the High Voltage (\pm HV) and \pm 100 V is only present during scanning. (After freezing the image the LED will be lit for approximate half a minute) Refer to Fig. 4.5-1.

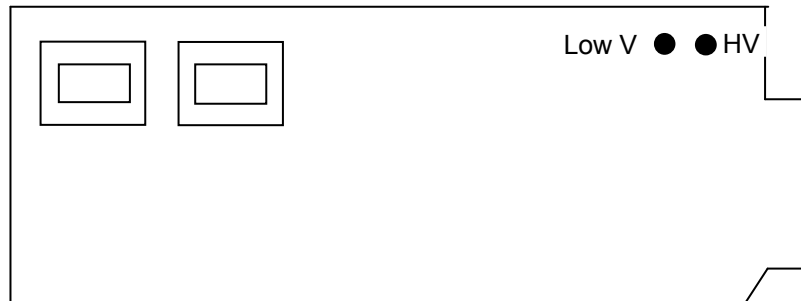

Fig. 4.5- 1 Voltage LED's.

Block Diagram of the Power Supply

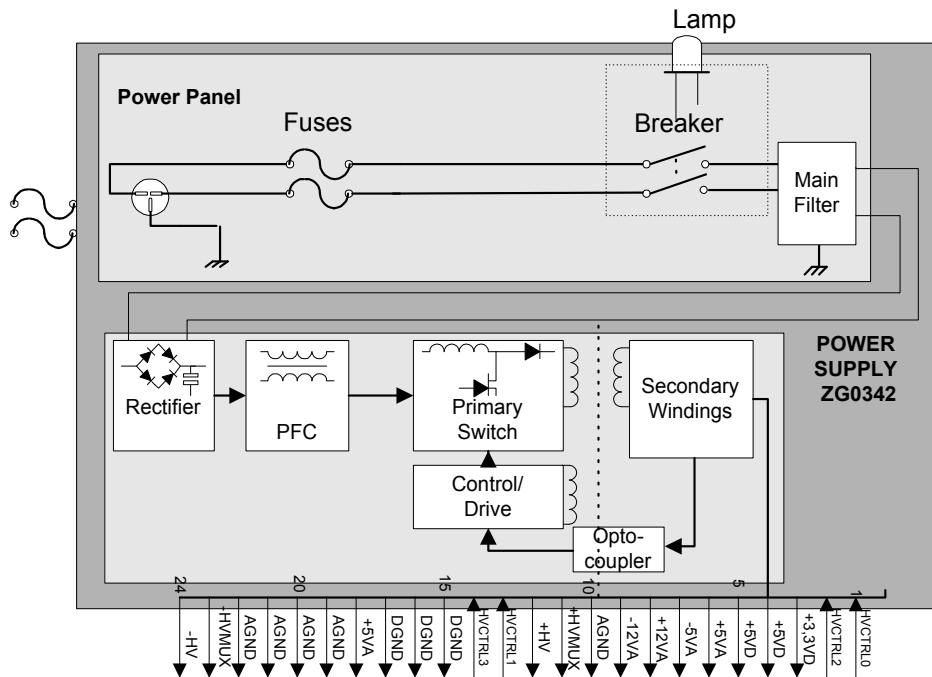

Fig. 4.5- 2. Power Supply ZG0342

If one or both of the Voltage LEDs are Off it indicates that one or more voltages are Missing. The reason is one of three:

- (1) A defective transducer shorting the HV
- (2) A short-circuit in the Console,
- (3) A Power Supply fault

What to do:

Try another transducer.

Switch off and disconnect the keyboard and the monitor . Switch on and observe the status of the LED's. If the Low V LED is "on" the keyboard or the monitor may be defective .

"Search for the short-circuit in the Console" is done by successively pulling out the PC boards. Remember to switch off the 1101 before the boards are removed

The power supply itself is checked by removing the supply from the 1101 and measuring the voltages on the power supply plug. Refer to Fig 4.5-3

Note:

The measured voltages does not reflect the tolerances from Table 4.5-1 as these are the values when the supply is loaded.

The Power Supply HV output can not operate with the power plug disconnected from the motherboard. By short circuiting pin 4 and pin 14 on the power supply plug the green HV-LED on the power supply should be on and from +68 to +76 Volts should be present at pin 12 (Ref. pin 10) and from -68 to -76 Volts should be present at pin 24 (Ref pin 10).

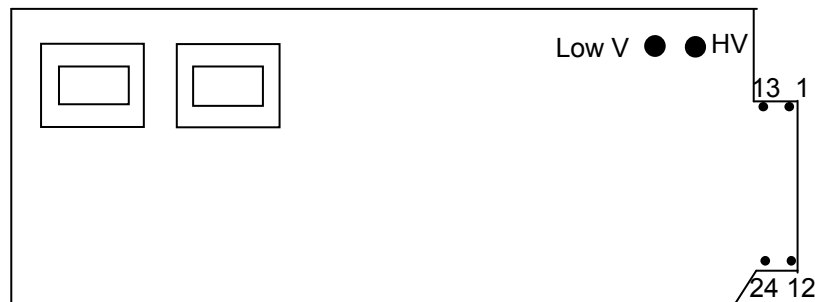

Fig. 4.5-3. PWR supply plug

Pin	In-/Output	Pin	In-/Output
1	HVCTRL0	13	HVCTRL1
2	HVCTRL2	14	HVCTRL3
3	+3.3VD	15	GND
4	+5VD	16	GND
5	+5VD	17	GND
6	+5VA	18	+5VA
7	-5VA	19	GND
8	+12VA	20	GND
9	-12VA	21	GND
19	GND	22	GND
11	+100VA	23	-100VA
12	+HV	24	-HV

Table 4.5-1 Pin connections

Power Supply Specifications

DC Output	Max Current	Ripple	REGULATION	PROTECTION Active	MIN. Load
+3,3 VD	1 A	50 mVpp	±5%	< 5 V, < 1.5 A	0.2 A
+5 VD	2 A	50 mVpp	5.1V, ±2%	< 6.5 V, < 4 A	0.5 A
+5 VA	5 A	50 mVpp	±5%	< 7.5 A	0.2 A
-5 VA	2.5 A	50 mVpp	±5%	< 4 A	0.2 A
+12 VA	3 A	50 mVpp	±5%	< 5 A	0.5 A
-12 VA	2 A	50 mVpp	±5%	< 4 A	0.5 A
+100 VA	25 mA	0.5 Vpp	±5%	< 50 mA	0
-100 VA	25 mA	0.5 Vpp	±5%	< 50 mA	0
+HV	75 mA	0.5 Vpp	±5%	< 110 mA	0
-HV	75 mA	0.5 Vpp	±5%	< 110 mA	0

Table 4.5-2 Table of voltage tolerances with load

4.6. Monitor

The 1101 is equipped with a 10" B/W Monitor.

Monitor Disassembling

To get access to the PCB remove the 1101 cover.

Missing picture on monitor

What to do:

- Check the power to the monitor.
- Check that the CRT-High Voltage is present. The CRT High Voltage build up can typically be heard during power on.
- Check cables/connectors.
- Try to connect an external monitor.
- If the picture is not present on the external monitor the problem is most likely located on the Core board, Motherboard or I/O board.

4.7. Software update

The software for the 1101 can be updated via the build-in floppy disk drive.

1. Insert the floppy disk labeled "Load 000" in the floppy drive.
2. Turn on the 1101.
3. When the line: "Type 2100 LOADER" appears (after approximately 3 seconds) then press **Shift, Alt, ***.
4. A repeating beeping then indicates that the software load menu has been accessed.

Type 2100 LOADER VP2767 (CB2100) 10-26-2001 08:48:14

```
Select command using <key>:  
<1> Upgrade scanner software using floppy disk  
<2> Upgrade scanner software using serial port  
<9> Reset all user programmed parameters (NVSS)  
<q> Quit, no upgrade performed
```

5. Press the **1** for "**Upgrade scanner software using floppy disk**" and follow the instructions on the screen.

Note ! Do not turn off the 1101 during the updates this may cause the Flash Proms on the Core board to fail !
6. At the completion of the software loading the 1101 will restart. After this reload press **Shift, Alt, ID** to check that the software version is correct.

By resetting the NVSS (by pressing **9** in the above menu) the applications(transducer setup), label library and bodymark library are set to factory default. If a default language different from English has been set by loading the "Language disk" then the names of the applications, label library, and bodymark library will be set to that language. Note ! Not all names may have been translated.

Note: Support of "Language disk" is only for units with boot-PROM VP2767 and sw. version 1.20 or above.

4.8. Error Log on Core Board

In case the scanner stops operating during normal use the CPU (Core Board) in some cases stores information in a error log. This log can be accessed via a PC and a terminal program e.g. Windows (Hyper)Terminal.

Note! The Error Log is stored until you delete it which means that you can also see old failures if present.

1. Connect the PC to the scanner via the RS232 with the cable EL4021 or similar.
2. Use PC terminal program e.g. Procomm or Windows Terminal. Com. settings: **19200 BPS N,8,1.**
3. Set DIP switch 8 down (scanner bottom).

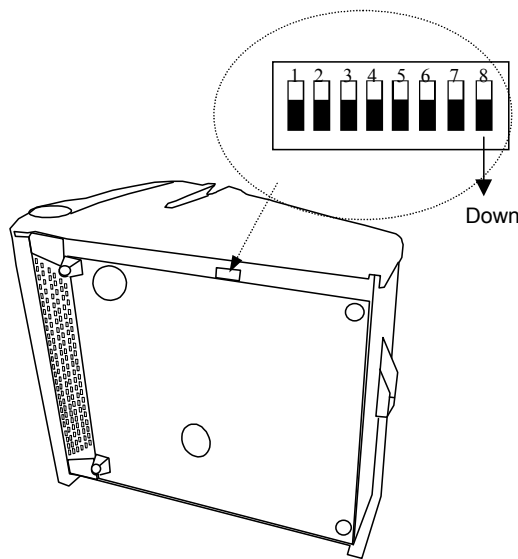

4. Switch on the scanner.
5. On the PC press **<N>** at the prompt:
"DO YOU WANT TO MODIFY JOB ? PRESS YES TO CONFIRM".
6. On the PC press **<N>** at the prompt:
"DO YOU WANT TO RESET TO DEFAULT SET_UP (Y/N) "
7. If any text in the error log, you will be prompted
"DO YOU WANT TO SEE THE POST MORTEM HISTORY ?"
Note ! This will only appear if the error log is not empty.
8. Then press **"y"**

Remember to re-set DIP switch 8 (Up), after turning the scanner Off.

If the contents of the error log does not make sense please then send a copy to the Service department at B-K Medical.

Section 5

ADJUSTMENT PROCEDURE

CONTENTS	PAGE
5.1. Introduction	5-2
5.2. Monitor Adjustment	5-2

Introduction

Most of the adjustable components in the 1101 are factory adjusted and need no further adjustment. **Do not attempt to make other adjustments than stated in this section.**

Monitor Adjustment

Necessary tools:

- A long, flexible, non-magnetic and non-conductive screwdriver.
1. Check which Video standard the scanner has been set to – refer to section 9: Dip switch setting.
 2. To get access to the potentiometers inside the monitor remove the handle and cover as described in section 6.

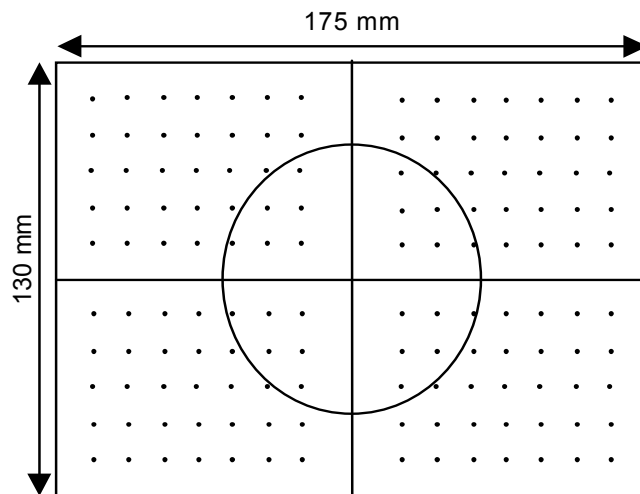

Fig. 5.2-1 *The Geometric Test Picture.*

3. Switch On the 1101 and press the **Shift, Alt** and **Probe(X)**. Then press **F5** to chose the Test picture. (Pressing **F5** toggles between Geometric test picture, all pixel off, and all pixels on)

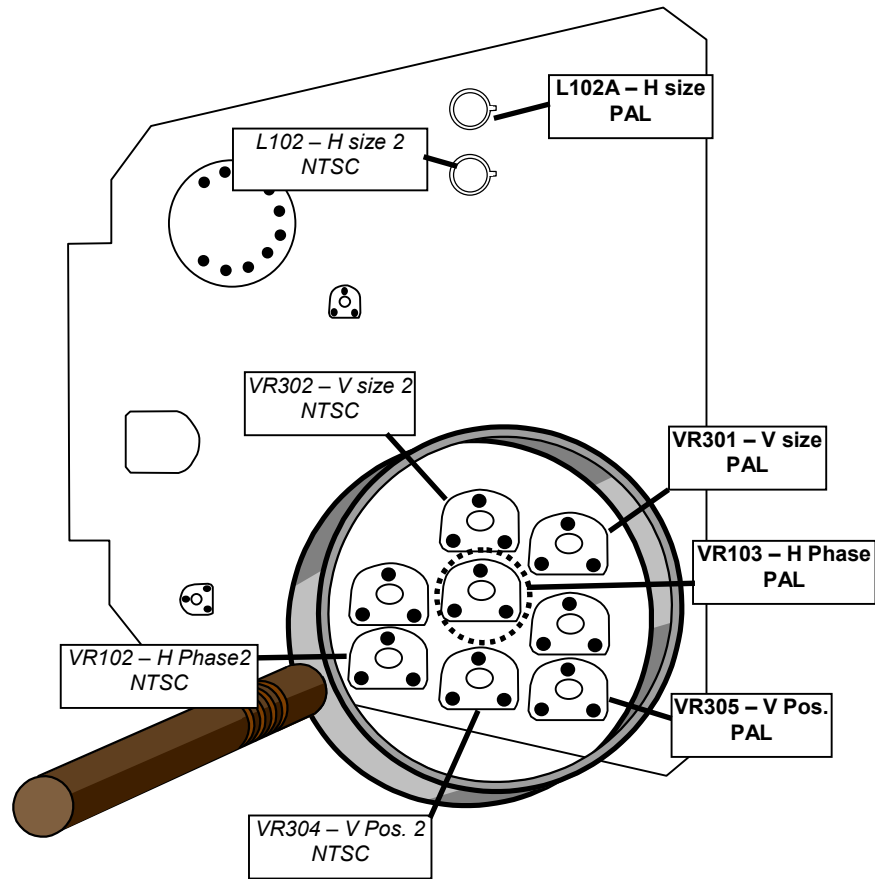

Fig. 5.2-2. Adjustment potentiometers/coils on the Deflection Board.

The following adjustments (step 3 - 11) are done on the Deflection PCB (refer to Fig. 5.2-2):

Allow the monitor to warm up for at least 15 minutes before you proceed with step 3.

3. Adjust the height on **PAL: V-SIZE1 - VR301** or **NTSC: V-SIZE2 VR302** so that the height of the test picture is 130 mm.
4. V-Position: Turn up the brightness until the background light is visible. Then adjust **PAL:V-POS11 - VR305** or **NTSC: V-POS/2 VR304** so that the test picture is located in the centre of the background light area.
5. Width: Adjust the width on **PAL: H-SIZE1 L102A** or **NTSC: H-SIZE2 L102** so that the width of the test picture is 175 mm.
6. H-Position: Adjust the position on **PAL: H-PHASE1 VR103H** or **NTSC: H-PHASE 2 VR102** so that the test picture is located in the centre of the background light area.
7. Switch Off the 1101 and re-assemble the Scanner.

This page is left blank intentionally

Section 6

MECHANICAL PARTS

CONTENTS	PAGE
6.1. Dismantling and Reassemble Procedures.....	6-2
6.1.1. Handle and Cover	6-2
6.1.2. Remove the keyboard.....	6-4
6.1.3. Getting access to the inside of the keyboard	6-5
6.1.4. Replacing the trackball	6-5
6.1.5. Removing the potentiometer module	6-5
6.1.6. Replacing the single input board	6-6
6.1.7. Replacing the Power Supply	6-8
6.1.8. Replacing the Fans	6-9
6.1.9. Getting access to the PC boards.....	6-10
6.1.10. Replacing the Front-end/Delay board	6-10
6.1.11. Replacing the Core board.....	6-11
6.1.12. Replacing the I/O board.....	6-11
6.1.13. Replacing the monitor and the Floppy Disk Drive	6-13
6.2. Exploded Views	6-15
6.2.1. 1101 part list.....	6-16

Dismantling and Reassemble Procedures

Handle and Cover

1. Disconnect the mains cable, remove transducer(s) from the transducer connector(s).
2. Remove the two hinge covers using a 2 mm Allen key, see Fig. 6. 1-1.

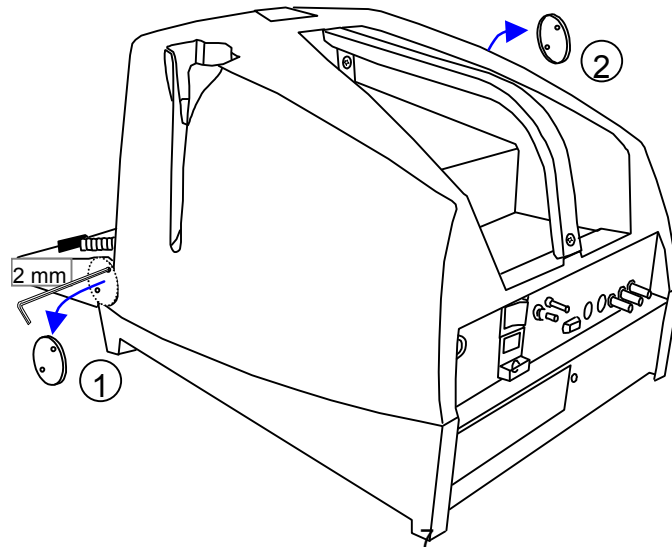

Fig. 6. 1-1. Removing the two hinge covers

3. Unscrew the two screws (M4×8 and M4×30) holding the handle and remove the handle, see Fig. 6. 1-2

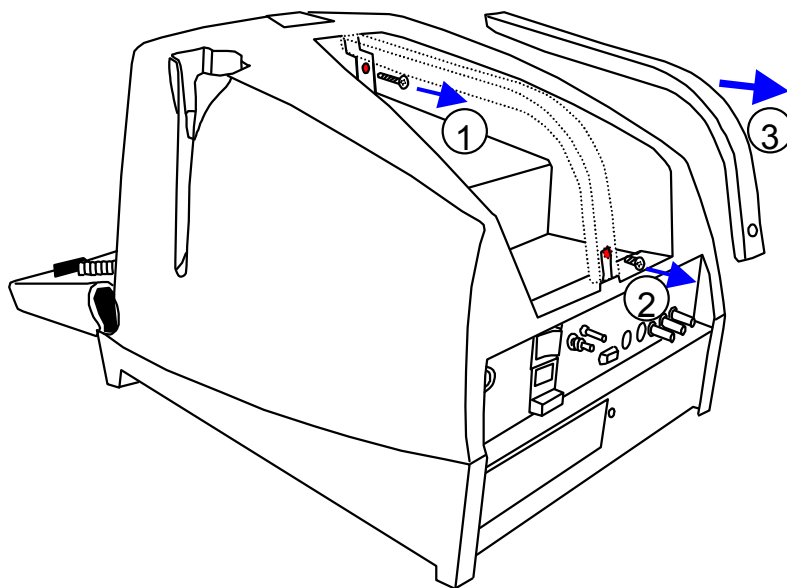

Fig. 6. 1-2. Removing the handle.

4. Unscrew the two screws (M4×8) on the back, see Fig. 6. 1-3.

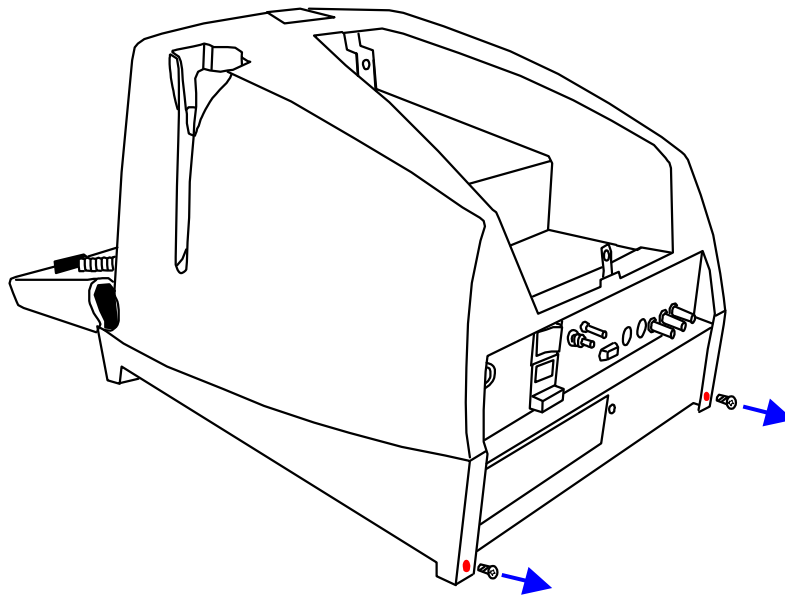

Fig. 6. 1-3. Screws for the cover.

5. Remove the cover, see Fig. 6.1-4.
Note that the cover is fixed in the two brackets so it has to be pushed up a few cm. and then spread apart from the keyboard hinge.

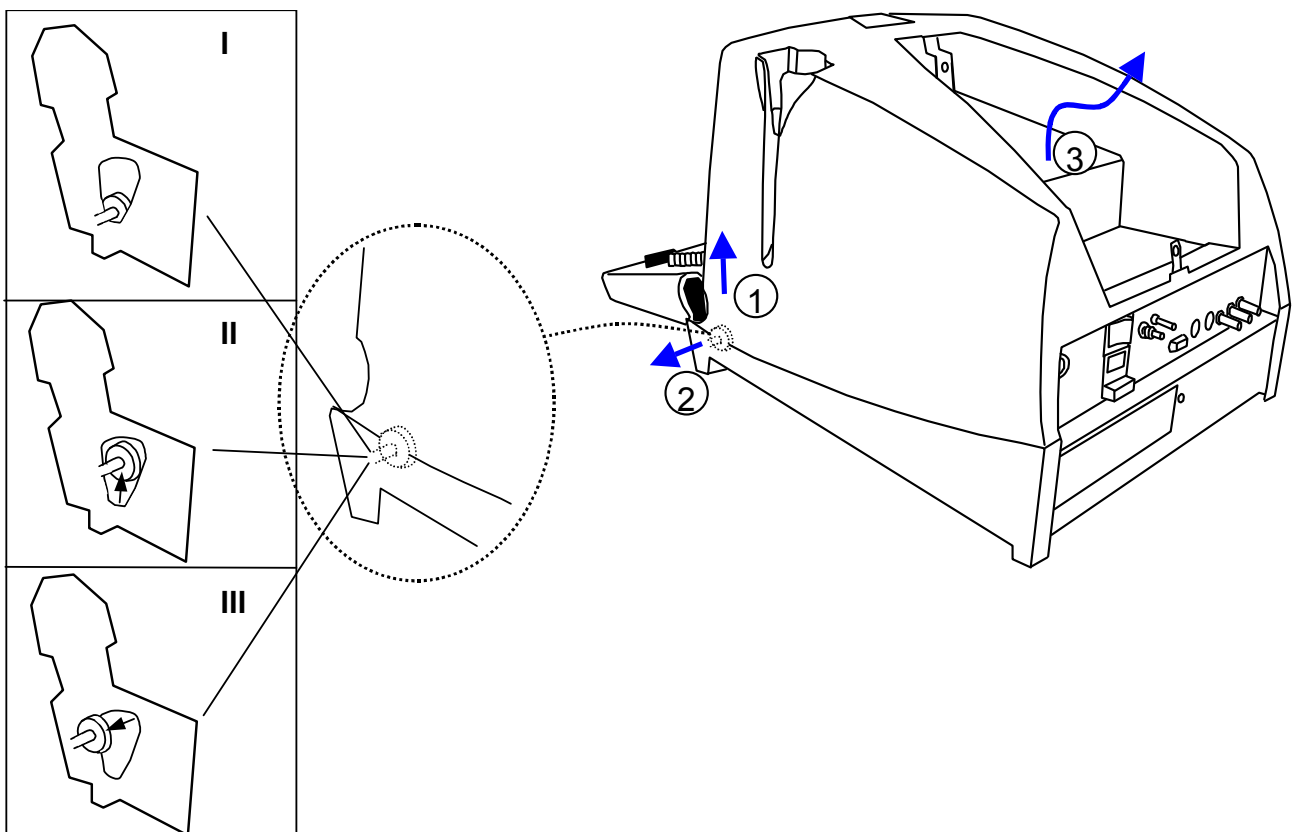

Fig. 6. 1-4. Removing the cover.

Remove the keyboard

Remove the handle and cover as described in section 0.

1. Unscrew four nuts (M4) holding the front plate (two on each side), see Fig. 6. 1-5.

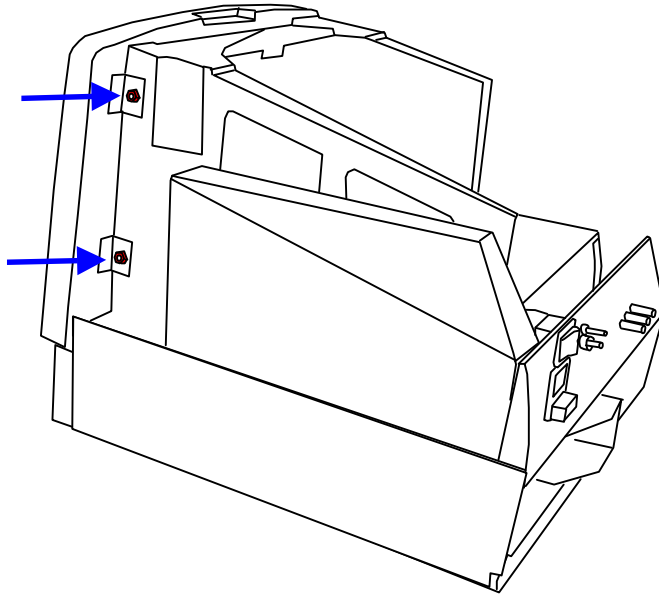

Fig. 6. 1-5. Nuts holding the front cover

2. Slide up the front plate.
3. Unscrew the two screws (M3×8) in each side holding the keyboard assembly, see fig. 6. 1-6.
4. Lift up the console and slide the keyboard assembly a few centimetres forward.
5. Disconnect the keyboard connector, see Fig. 6. 1-6.

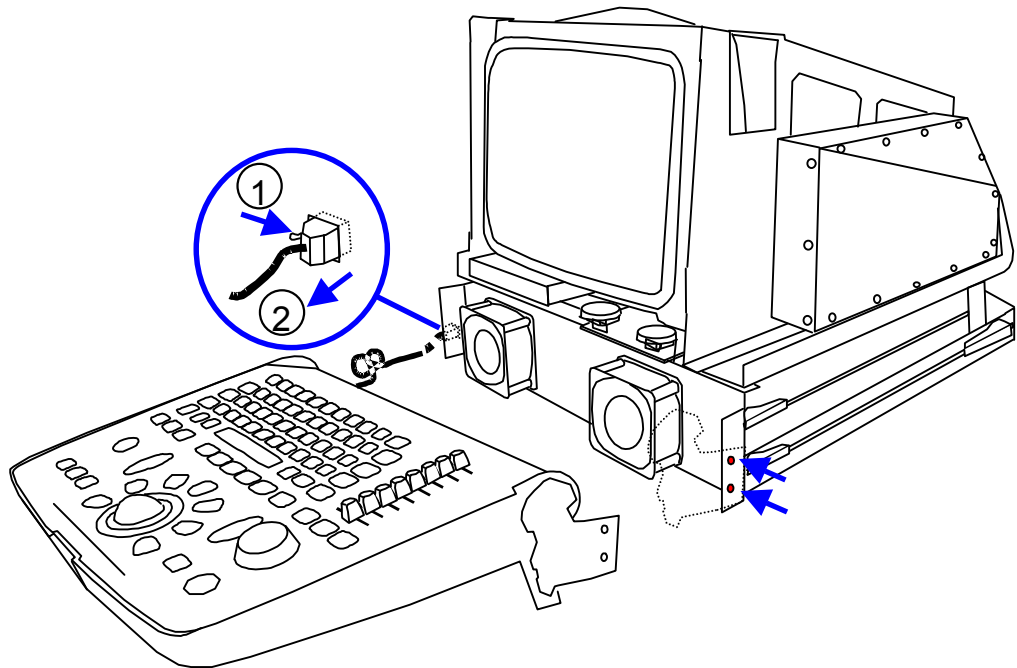

Fig. 6. 1-6. Screws holding the keyboard and the keyboard connector

Getting access to the inside of the keyboard

Remove the handle and cover as described in section 0 and remove the keyboard as described in section 0.

1. Unscrew the two (M3×6) screws holding the keyboard, see Fig. 6. 1-7.
2. Use a screwdriver to pull up the keyboard which are fixed with four "snap locks"

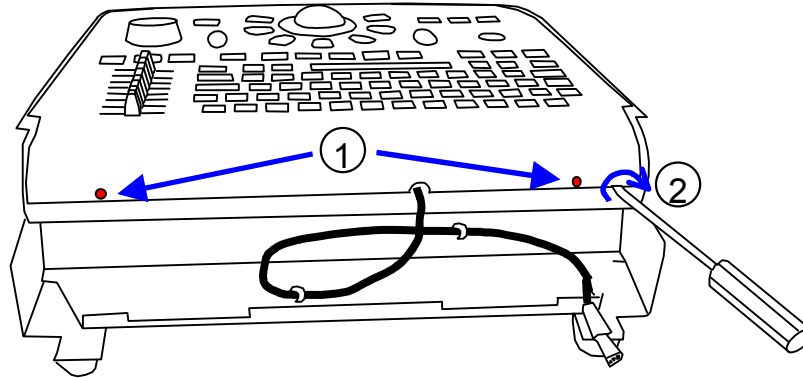

Fig. 6. 1-7. Screws holding the keyboard

Replacing the trackball

Remove the keyboard and get access to the keyboard interior as described in section 0.

1. Disconnect the cable from the Potentiometer board, see Fig. 6. 1-8.
2. Unscrew the four nuts (M3) and remove the trackball, see Fig. 6. 1-8.

Removing the potentiometer module

Remove the keyboard and get access to the keyboard interior as described in section 0.

1. Disconnect the three cables from the Potentiometer board, see Fig. 6. 1-8.
2. Unscrew the six screws (M3×6) and remove the board, see Fig. 6. 1-8.
Note ! Under one of the screws is a washer, see below.

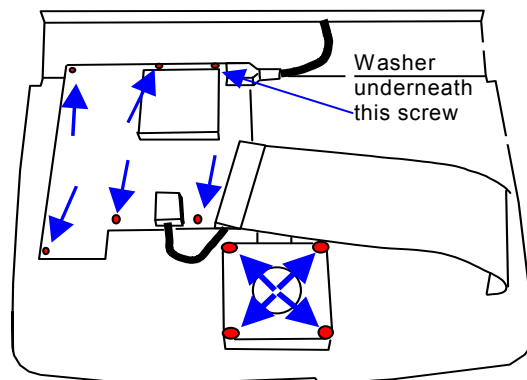

Fig. 6. 1-8. Items attached to the back of the keyboard

Replacing the single input board

Remove the handle and cover as described in section 0

1. Unscrew the 15 screws (M3×6) holding the metal shield box and remove the metal plate, see Fig. 6. 1-9.

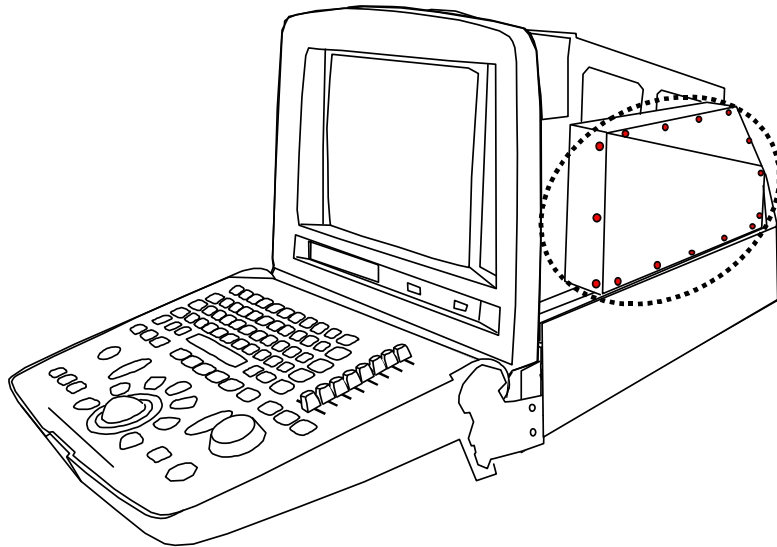

Fig. 6. 1-9. Screw holding the metal shield box covering the Single module

2. Disconnect the connector to the Mother board, and the connector to the transducer connector see Fig. 6. 1-10.
3. Unscrew the four screws holding the board and remove the clip holding the power regulator see Fig. 6. 1-10.

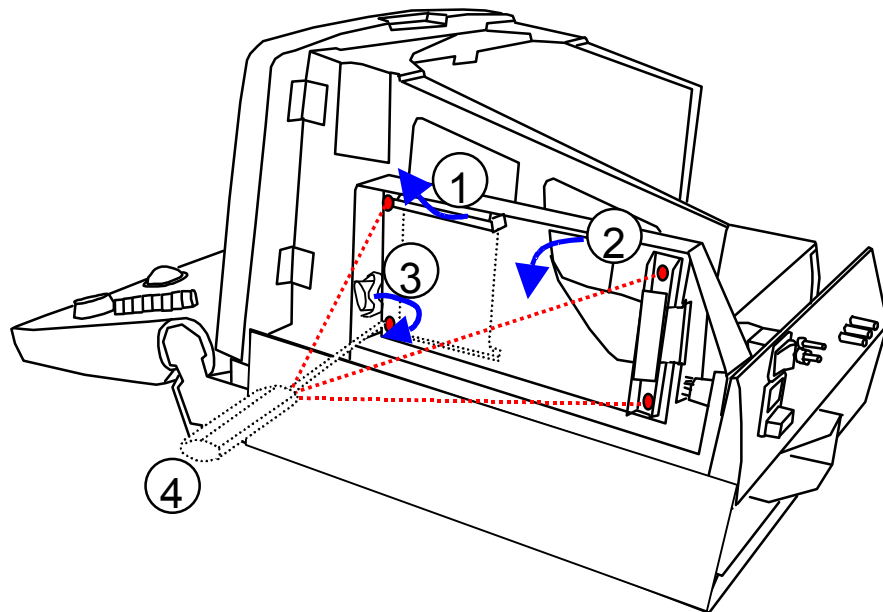

Fig. 6. 1-10. Connectors and screws on the single module

4. Unscrew the three nuts holding the Single Module box and remove the box, see Fig. 6. 1-11.

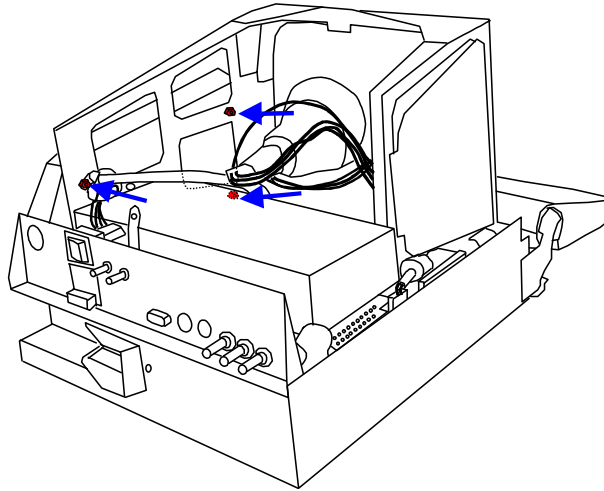

Fig. 6. 1-11. Nuts holding the Single Module box

5. Replace the single module board and reverse the dismantling procedures

Replacing the Power Supply

Remove the handle and cover as described in section 0

1. Unscrew the two nuts (M4) holding the power supply, see Fig. 6. 1-12.

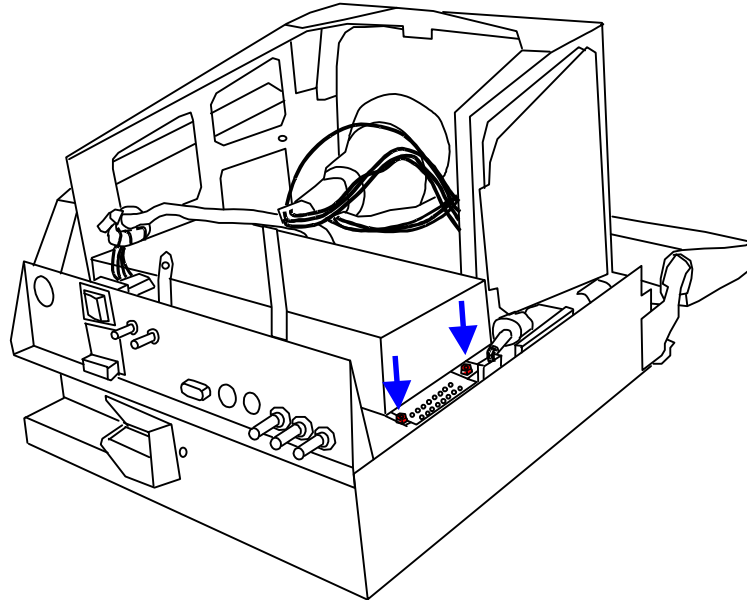

Fig. 6. 1-12. Nuts holding the Power Supply

2. Unscrew the two screws on the bracket holding the Power Supply and remove the bracket, see Fig. 6. 1-13.
3. Disconnect the mains connectors to the Power Supply, see Fig. 6. 1-13.

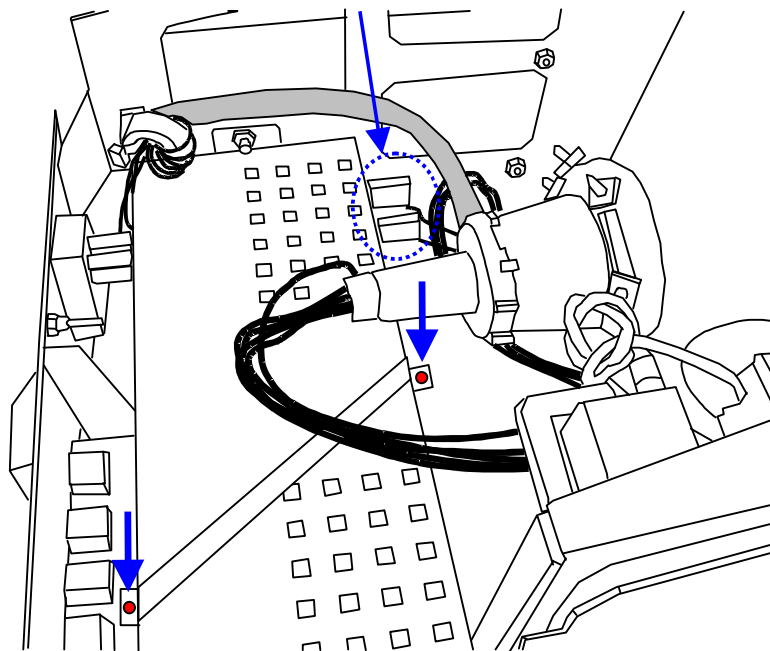

Fig. 6. 1-13. Bracket holding the Power Supply and connectors to it

- Carefully lift up the Power Supply disconnecting the connector attached to the Motherboard see Fig. 6. 1-14.

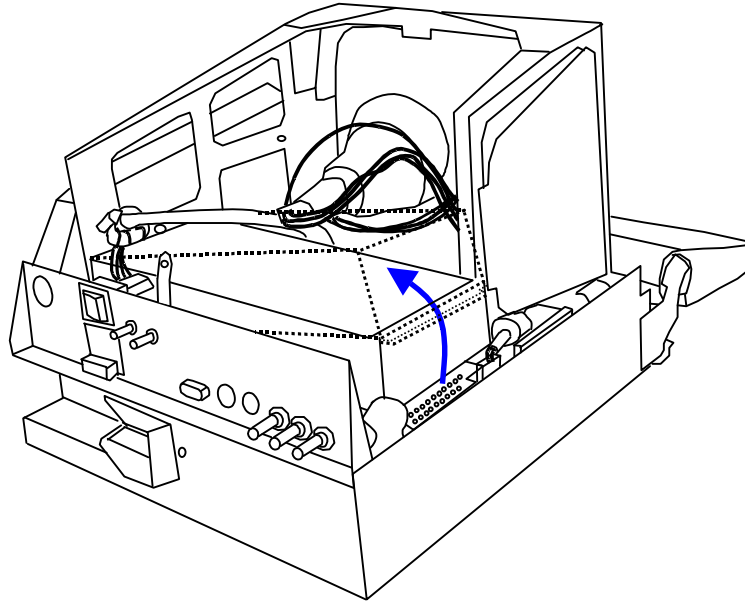

Fig. 6. 1-14. Disconnecting the power supply connector on the Motherboard

- Replace the power supply and reverse the dismantling procedure.

Replacing the Fans

Remove the handle and cover as described in section 0.
Remove the keyboard as described in section 0.

- Unscrew eight screws holding the fans and disconnect the connector attached to the Motherboard, see Fig. 6. 1-15.

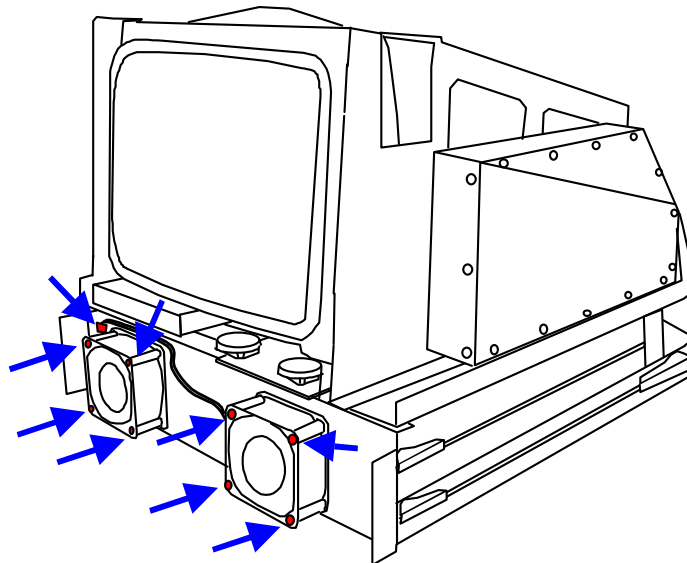

Fig. 6. 1-15. Screws holding the fans and the fan connector

Getting access to the PC boards

Remove the handle and cover as described in section 0.

1. Unscrew the 14 screws (M3×6) holding metal cover, see Fig. 6. 1-

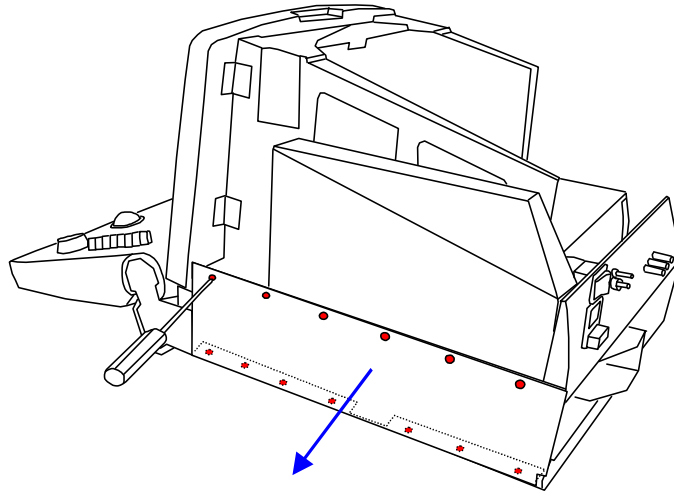

Fig. 6. 1-16. Screws holding the metal cover for the PC boards

Replacing the Front-end/Delay board

Remove the handle and cover as described in section 0.
Get access to the PC boards as described in section 0.

1. Unscrew the screw next to the transducer connector, see Fig. 6. 1-17.

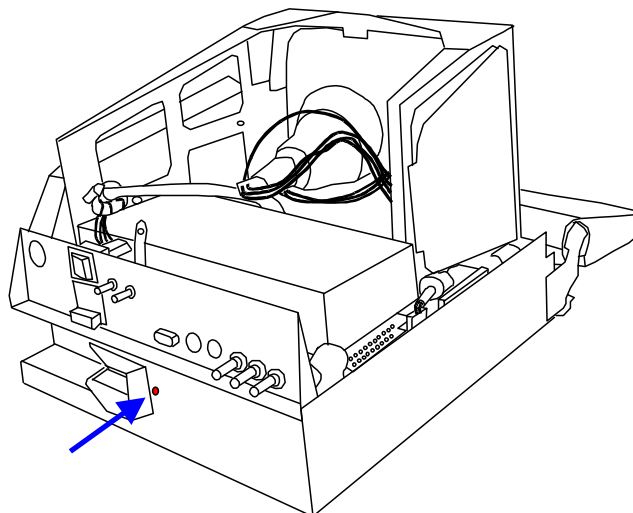

Fig. 6. 1-17. Screw holding the Front-End/Delay board

2. Pull out the board.
3. Install the new Front-end board and reverse the dismantling procedures.

Replacing the Core board

Remove the handle and cover as described in section 0
Get access to the PC boards as described in section 0.

1. Pull out the Core board approx. 5 cm. and disconnect the cable attached to it see Fig. 6. 1-18.

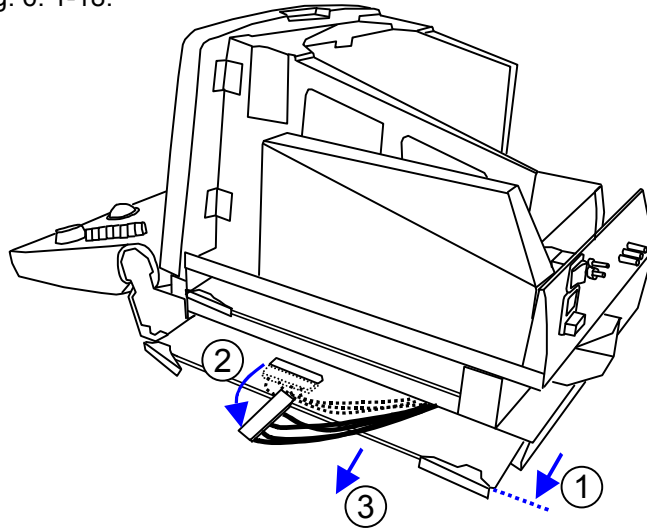

Fig. 6. 1-18. Connector on Core board to be disconnected

2. Slide out the Core board.
3. Install the new Core board and reverse the dismantling procedures.
4. Set the clock on the system to the right time and date. Refer to the user guide.
Note ! The user set-up will also be set to factory (default) setting.

Replacing the I/O board

Remove the handle and cover as described in section 0

1. Unscrew the nuts ($\frac{1}{2}$ ") on the three connectors and disconnect the cable going to the Motherboard, see Fig. 6. 1-19.

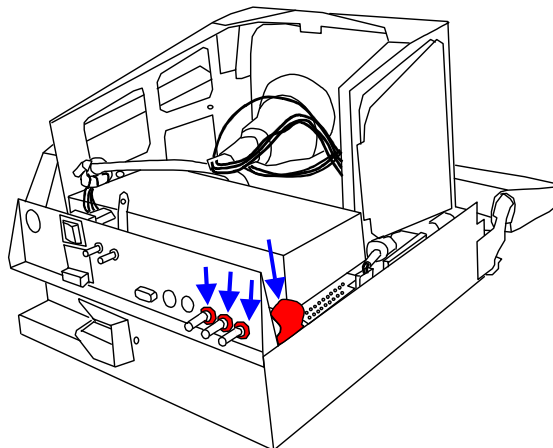

Fig. 6. 1-19. Nuts to be removed and connector to Motherboard

2. Install the new I/O board and reverse the dismantling procedures

Replacing the monitor and the Floppy Disk Drive

Remove the handle and cover as described in section 0.
Remove the keyboard as described in section 0.
Remove the Power Supply as described in section 0.
Remove the Single Input Module (if Mounted) as described in section 0.

1. Disconnect the video, the Single module (if installed) and the Floppy disk connector from the Motherboard, see Fig. 6. 1-20.

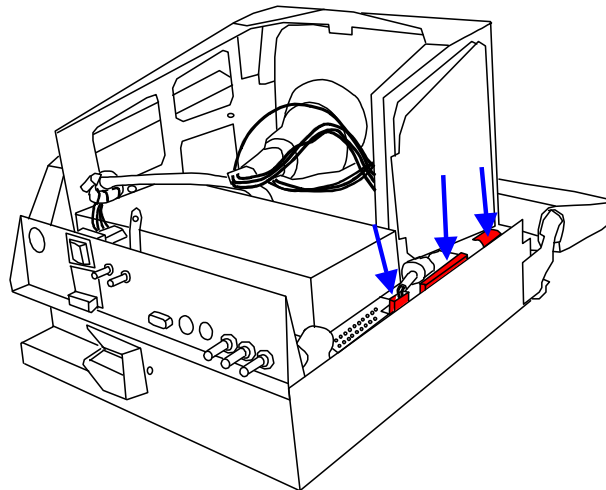

Fig. 6. 1-20. Video, Single Module, and Floppy disk connector on the Motherboard

2. Unscrew the four nuts (M4) holding the monitor frame and lift up the monitor assembly see Fig. 6. 1-21.

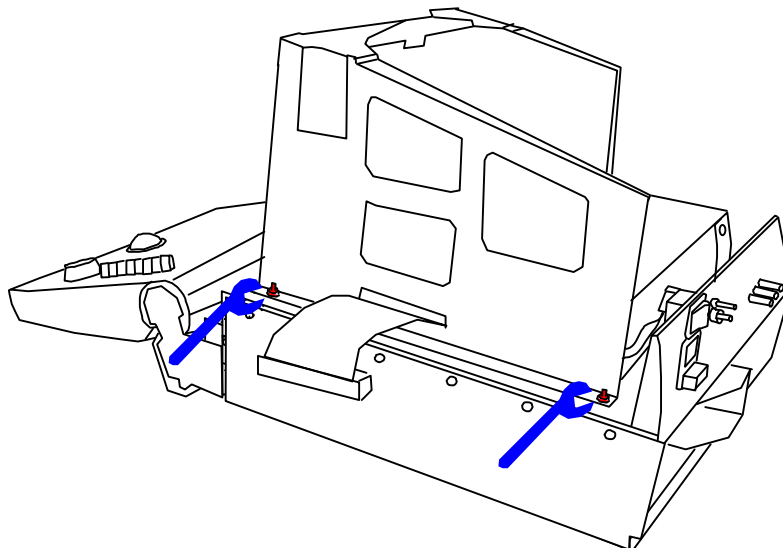

Fig. 6. 1-21. Nuts holding the monitor assembly

3. Remove the floppy disk drive from the Monitor assembly by unscrewing the three screws underneath the monitor, see Fig. 6. 1-22.

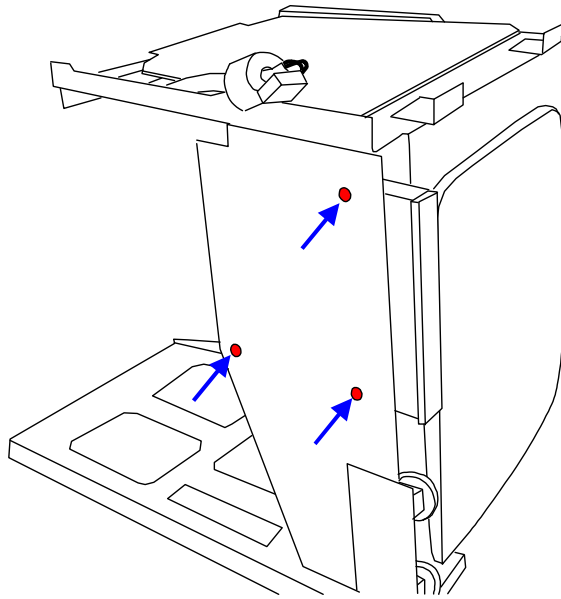
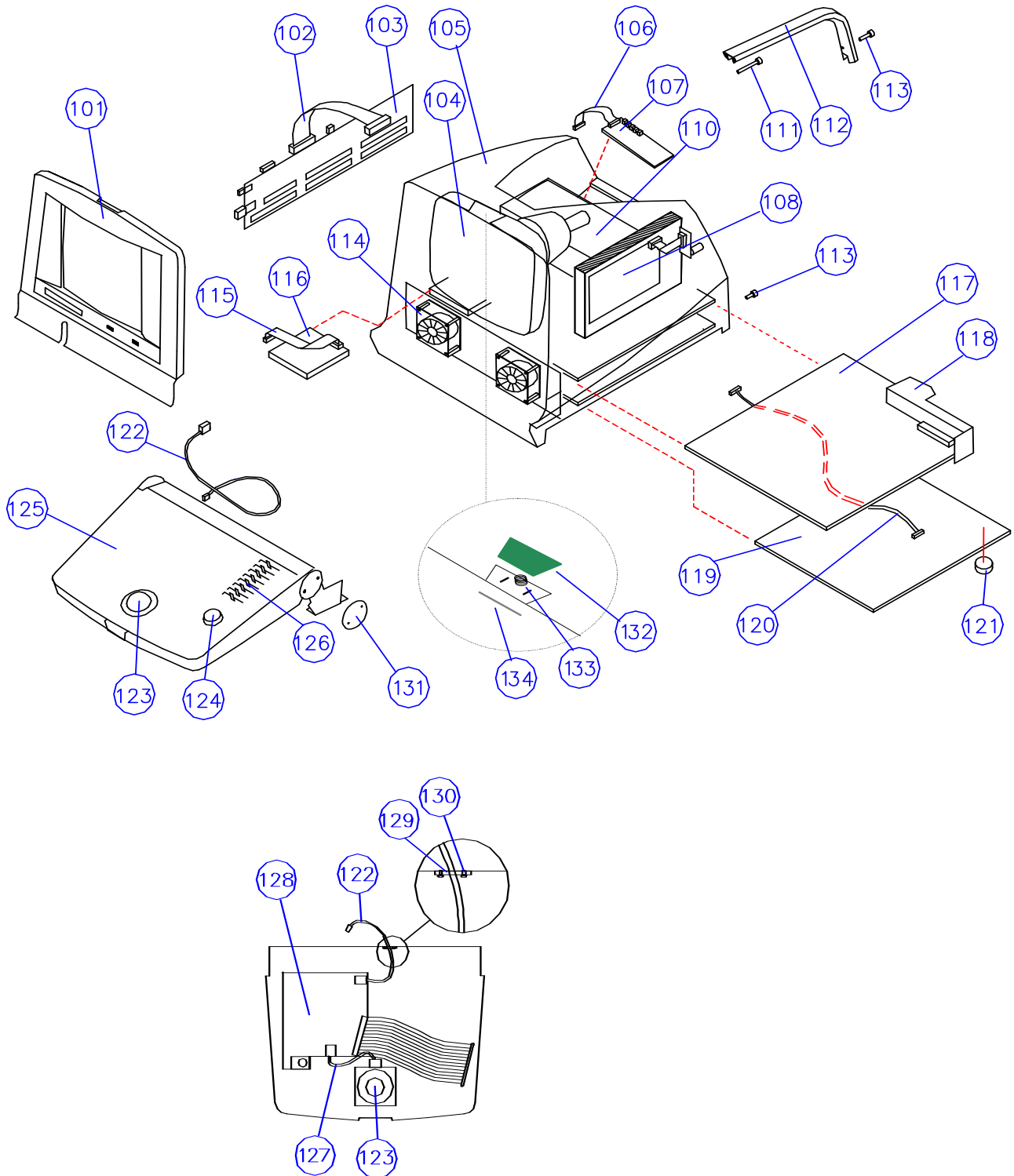

Fig. 6. 1-22. Screws holding the Floppy Disk Drive

6.1. Exploded Views



1101 part list

Item no.	Part no.	Quantity	Description
101	DZ 2324	1	Front cover
102	AQ 1677	1	Flat Cable for Single Module
103	ZH 0689	1	Motherboard
104	ZV 0056	1	Monitor Assembly
105	DZ 2322	1	Cover
106	AQ 1674	1	Flat Cable for I/O board
107	ZH 0690	1	I/O Board
108	ZN 0020	1	Single Element Transducer Module
110	ZG 0342	1	Power Supply
111	YT 1430	1	Screw for Handle (M4×30)
112	ZN 0021	1	Handle
113	YT 1408	3	Screw (M4×8)
114	ZN 0023	2	Fan
115	AQ 1673	1	Flat Cable for Floppy Disk Drive
116	UL 0018	1	Floppy Disk Drive
117	ZE 0732	1	Front-end/Delay board
119	ZD 0761	1	Core Board
120	AQ 1671	1	Video Cable
121	QB 0041	1	Battery (part of Core Board)
122	AO 0427	1	Keyboard Cable
123	NT 0256	1	Tracker ball
124	DP 0876	1	Gain button
125	NT 0159	1	Keyboard Overlay
125	ZN 0014	1	Keyboard Complete (incl. of item 122-130)
126	DP 0888	8	Potentiometer buttons
127	AO 2016	1	Trackball cable
128	ZH 0688	1	Potentiometer board
129	GU 1776	1	Cable relief bracket
130	YT 1306	2	Screw
131	ZN 0022	2	Hinge covers
132	DZ 2321	1	Keyboard lock
133	DL 2124	1	Spring
134	YC 0002	1	Pin for keyboard lock
	YT 6308	12	Screw Ø3×6
	YT 3306	44	Screw M3×6
	YM 0335	4	Nut M3(for trackball)
	YT 1306	18	Screw M3×6
	YM 0486	10	Nut M4 (Monitor, single module and PS)
	YT 1336	8	M3×36 (for Fans)
	YM 1300	3	½" Nut (for I/O board connectors)
	YT 2306	15	M3×6 (for Single Module)
	YT 1312	2	M3×12 (for Single Module)

This page is left blank intentionally

Section 7

PREVENTATIVE MAINTENANCE

CONTENTS	PAGE
7.1. Introduction	7-2
7.2. Necessary Equipment	7-2
7.3. What to do	7-3

7.1. Introduction

The purpose of the Preventative Maintenance is to ensure the performance and stability over the years of use.

Note - The Preventative Maintenance should be performed once every year.

Preparation of the Preventative Maintenance is essential as it in most cases will take place at the hospital as part of a Continuity Agreement.

The Preventative Maintenance consists of eight steps. Some of these steps refer to specific sections in the Service Manual. If errors occur during the procedure go to TROUBLESHOOTING, Section 4.

7.2. Necessary Equipment

The equipment, necessary for a preventative visit is divided into 3 packages.

A: Parts necessary to ensure the performance and stability of the system.

Check in the Service Informations (Hot-Line) if there are any modifications to be done.

B: Parts necessary to meet customers complaints.

Before arranging the visit, check if the customer has any complaints and bring the necessary spare parts and tools to solve the problem.

C: Tools and equipment necessary to perform the Preventative Maintenance.

The only equipment necessary to perform the Preventative Maintenance is the equipment used in the Electrical Safety Test and phantoms for the Checking Procedure:

For the Checking Procedure:

Transducer Phantom, model 254 (B-K no.WQ 0973) for checking a 1101 scanner equipped with Array- and Single Element Transducers.

Transducer Phantom, type 251 (B-K no. WQ0972) for checking a 1101 scanner equipped with the Endosonic Probe 1850.

For the Electrical Safety Test:

Testers required:

Safety Tester

HV Tester

WJ 0246

HV Test Plug for Mains

WB 1275

HV Test Adapter for Transducers (for array transducers)

Note:

It is recommended to bring additionally the Static Control Service Kit, type 3M 8501 (B-K no. WQ0969) or similar in case one of the static sensitive PC Boards is to be removed from its location in the 1101.

7.3. What to do

1. Users Comments and Corrections

Check with the user that the system is operating satisfactorily. A number of malfunctions can be corrected by changing set-up's.
If an error is obvious, correct it at this state.

2. Modifications

In accordance with the Service Informations (HOT-LINE) perform modifications necessary to ensure performance and stability of the unit.

3. Mobility

Check that the keyboard can be moved up/down and locks in the upper position.
Check that the trackball moves smoothly

4. Fans inside the 1101

Observe that the two fans in the front of the 1101 runs.

5. Checking Procedure

To verify proper operation of the main functions perform the CHECKING PROCEDURE, Section 3.

6. Peripherals

This is to verify the function of the video output and the peripherals used with the 1101 System.

Following peripherals used with the 1101 are supported by B-K Medical

EQ 4056 – VCR (Super VHS AG-MD380)
EQ 4071 – Video Printer (Sony UP-895CE)

Take a picture/print and check the quality. If necessary adjust the peripheral using the instruction manual for the product.

7. Adjustment Procedure

If necessary, perform an adjustment of the Monitor using the ADJUSTMENT PROCEDURE, Section 5.

8. Electrical Safety Test

Verify that the system complies with IEC 60601-1 using the Electrical Safety Test, Section 1

This page is left blank intentionally

Section 8

THEORY OF OPERATION

CONTENTS	PAGE
8.1. Introduction	8-2
8.2. General Description.....	8-2
8.2.1. Configurations	8-2
8.2.2. Block Diagram	8-3
8.3. PC Board Description.....	8-5
8.3.1. Front End/Delay Board	8-5
8.3.1.1. The Incremental Analog Beamformer (IAB)	8-7
8.3.2. Core board	8-9
8.3.2.1. CPU system	8-9
8.3.2.2. Real-time Scancontroller (RTSC)	8-9
8.3.2.3. Scanconverter	8-10
8.3.2.4. Floppy Disk	8-10
8.3.3. Single input module	8-11
8.3.4. Power Supply	8-12
8.3.5. Monitor.....	8-13
8.3.6. 1101 Test facilities	8-14

Introduction

This section describes the theory of operation of the Diagnostic Ultrasound System 1101.

This description is divided into two separate sub-sections:

8.2. General Description

Supported by a complete block diagram, this section aims to give you an understanding of the interaction between modules, PC Boards and major function blocks. It explains briefly the main signal flow through the 1101 system.

8.3 PC Board Description

This section provides an overall description of each PC Board, explaining the main function of all function blocks on the board. Furthermore the section contains a description of Single Transducer module and the Monitor.

General Description

The following aims to give you a brief and easily read description of how the different modules and parts of the Diagnostic Ultrasound System 1101 are related to each other and how they function together as a system. The complete block diagram shown on page 8-5 should be used for reference while reading this section.

Configurations

The Diagnostic Ultrasound System 1101 is configured for use in B and M-Mode.

The 1101 is equipped with the following boards/ subassemblies:

Front End/ Delay board (FE/DLAY)

Core board

Mother board (Back plane)

I/O board

Power Supply

Monitor

Keyboard (subassembly)

Potentiometer and Gain Board (part of keyboard)

Track Ball (part of keyboard)

As options the 1101 system can be equipped with a Single Element Transducer Module and a floppy drive.

Block Diagram

The description of the PC Boards follows the signal flow in the 1101 system.

Refer to Fig. 8.2-2 1101 Block Diagram

The signal path starts at the Front End/ Delay Board where the transmit beam signal profile is generated.

The beam profile is fed to a 32 channel transmit driver and then directed to the active transducer connection.

The echo signals are routed from the active transducer connection to the preamp/TGC1 on the Front End/delay board. The signals are derotated and at the same time added together two by two according to their delay requirements to reduce the number of signal lines. The echo signals are filtered and delayed with different delays to convert the arc shape of the echo signals to a straight line. The signals are then added together to form a single signal representing the reflection from the scanned object.

On the Core Board the analog signal is converted to an 8 bit digital signal.

On the Core Board the digital signal is processed and converted into a composite video signal for use in the Monitor. Besides the scanning image the graphics are mixed into the video signal. The Core Board controls the signal flow through the system and the whole timing in respect to the active transducer. It also handles input/output to Keyboard, Foot Switch, Copy Trigger and Floppy Disk drive.

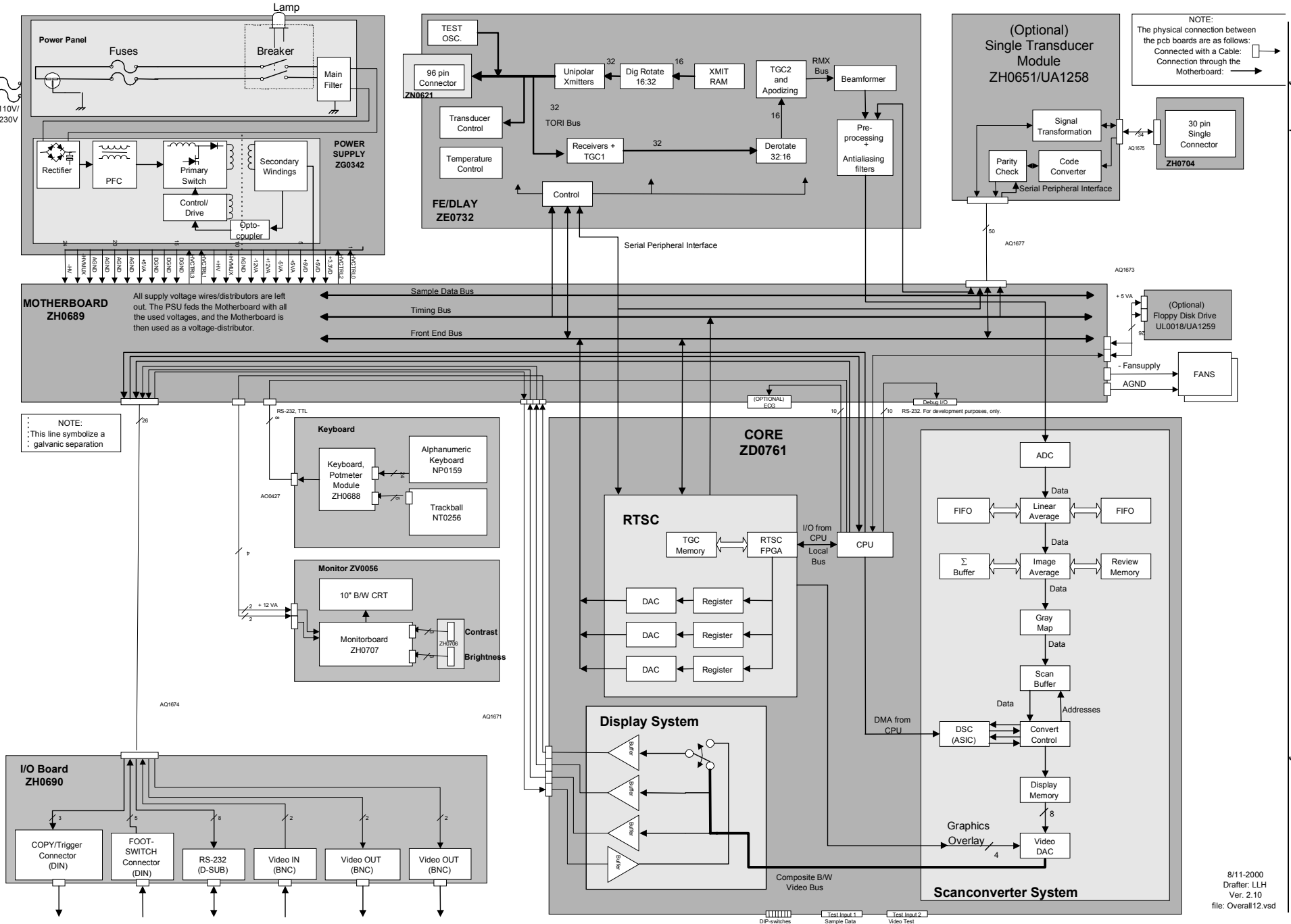

Fig. 8.2-1. 1101 Block Diagram.

B11101-B

PC Board Description

This section provides an overall description of each board, explaining the main function of all function blocks on each board.

Front End/Delay Board

Block diagram 1101 Front End/Delay board

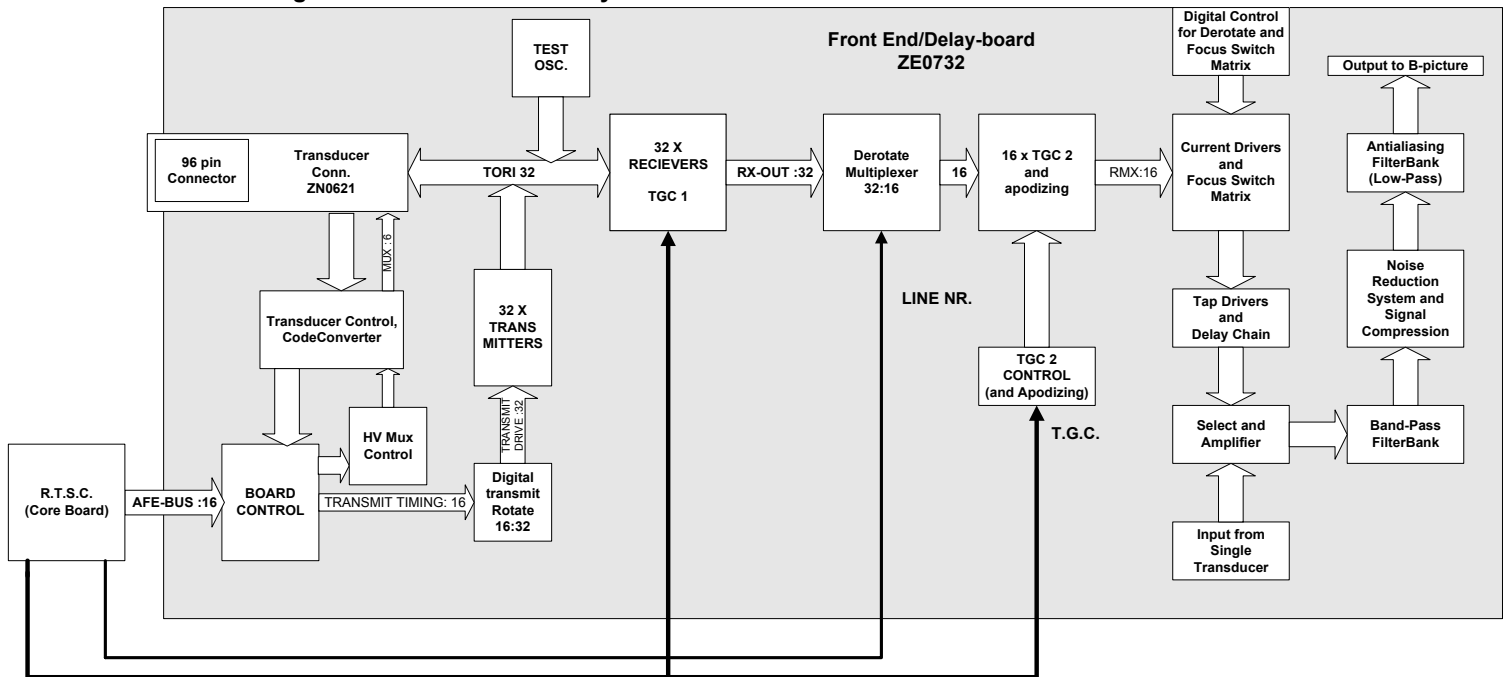

DRW_ID:Des_0392.doc 17-05-00

Fig. 8.3-1. Front End/Delay board

The Front-end/Delay board consist of one array transducer connectors, 32 receivers with preamplifiers and TGC, a board control system, a transmit rotate circuit, 32 transmit pulse amplifiers, and a test oscillator.

The array transducer connector is a 96 pin connector that fits the type 85XX array transducers. The transducer code interface circuit, translate the transducer codes to a serial data stream which is sent to the core board.

The Board control which is set up by the Core board holds the xmit-RAM (transmit timing) which is loaded with the beam profile of the active transducer. The 16 channels transmit timing data are sent to the Transmit rotate block where they are folded and rotated digitally. The resulting 32 channels (bits) pulses are then amplified in the Transmit amplifier and finally sent to the transducer. The output of the transmitters is controlled by a set of 8 bit D/A converters.

The Receiver circuit consist of 32 current preamplifiers and TGC stages driving the receive derotate multiplexer. The TGC Amplifiers compensates for the attenuation of the ultrasound wave in human tissue. This is done in a voltage controlled amplifier by increasing the gain with time, that is the greater the depth of the echo signal the greater the degree of amplification.

The purpose of having transmit/receive channels is to focus the ultrasound in one point; the focal point. The 32 echoes received by the 32 transducer crystals are therefore equivalent to one echo pulse received from the focal point.

The Front end/Delay board also holds a test oscillator used for fault finding.

The signal lines from the receiver are lead into a bank of switches in a 32:16 configuration which derotates the 32 symmetrical received channels into 16 independent channels for TGC and beamforming. The switches consist of nine 8:16 cross-point switches, with configuration data in a local RAM accessible from the Core board CPU.

After the derotation of the signals they are amplified in 16 TCG amplifiers including current-to-voltage conversion and circuitry for receive apodising.

A principle called Incremental Analog Beamformer **IAB** (see detailed description below) is used for beamforming of the received echo signals. The IAB consist of one single chain of delay-lines. This delay chain performs the dynamic receive focus by delaying the signals from the transducer element pairs into a time correlated beam signal. This is obtained by moving the input position of each signal to the delay chain, as the delay requirement is changing as a function of time. The system can be considered as a zone-switching system with 8000 different zones, in which the width (in tissue) of each zone is less than 0.2 mm.

At the same time a step-variable amplifier provides the final setting of the beam-signal amplitude in steps of 0.5 dB (from -11.5 to +20dB) before entering the bandpass-filter. The resolution and gain settings of this amplifier is designed to compensate for level difference between Odd/Even apertures. The step variable amplifier is controlled in parallel with the settings of the delay system in accordance with a set of gain values, which are located in the focus table along with the delay information.

The settings of gain produce switching noise which is added to the beam signal. The sum of the beam signal and all the switching noise is passed through the band-pass filtering and on to the Noise Reduction System.

The Noise Reduction System is a digital system based on the fact that the switching noise is the same for each focus table.

Each time a new focus table is to be used, the system requires that an "empty" receive period is performed as switch-noise reference ("empty" means: without any transmission taking place). During this reference receive period, a digital representation of the switch signal is saved in a memory device. During the following receive periods, the beam signal contains the sum of the echo signal and the switch signal. This sum signal is digitized, and the memorized part of the beam signal representing the switch signal (noise) alone, is digitally subtracted from the sum.

The noise reduced digital beam signal is then digitally detected, and the signal is processed. Finally, the signal amplitude is digitally converted into logarithmic form. The mapping from linear to logarithmic form is based on values stored in a writeable memory device.

The digital output of the lin/log conversion is fed to a 10-bit D/A converter and thereby converted back to analog form. From here, the analog signal passes through the low-pass anti-aliasing filters and on to the final 8-bit A/D conversion. The output of this converter is the digital input to the scanconverter (on the Core board). The selection of LP-filter and the rate of the final A/D conversion is set by the RTSC (on the Core board) and is thus independent of the beamformer function.

The Incremental Analog Beamformer (IAB)

The IAB represents a new concept in Dynamic Receive Focus for scanning with Array transducers.

The Incremental Analog Beamformer uses only one simple chain of delay components and a signal switching matrix for connecting the transducer signal to the delay line. During the programming of the signal connections only one signal line is changed at a time. The method of changing just one signal connection at a time is referred to as an incremental change of delay setting rather than a zone based system with many changes in each programming cycle.

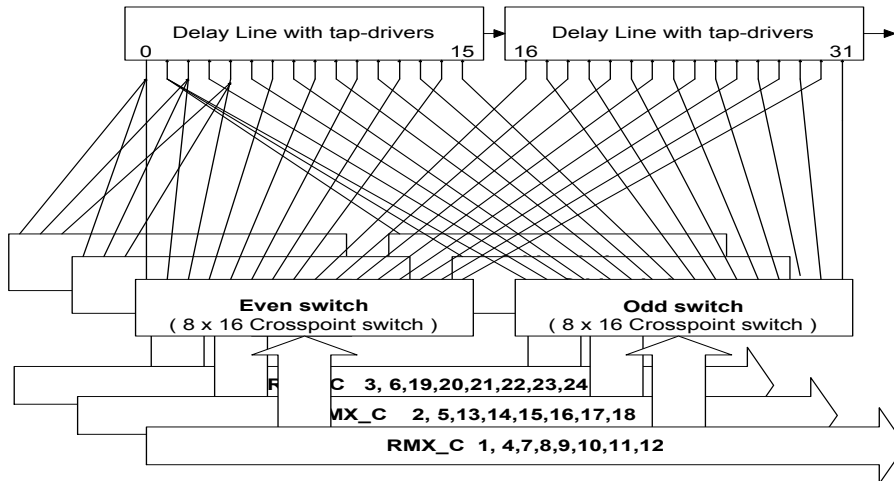

Fig. 8.3-2. IAB (Simplified)

Fig. 8.3-2. shows an example of 16 signal lines connected to two sections of the delay chain. The signals RMX 1-16 is generated by “folding” the 32 channels used in the 1101 scanner. The crosspoint switches connects the RMX signals to different sections of the delay line, where each bank (even/odd) is switched at 10 Mhz. The fact that the signals are switched at 10 Mhz creates a “zone switching system” with thousand of different zones.

Switching noise is removed by using an “empty” scanline at the beginning of each new sector scan. The switching noise is digitized and stored in a RAM . During the remaining lines of the following sector scan the noise reference values are digitally subtracted from the echo signal.

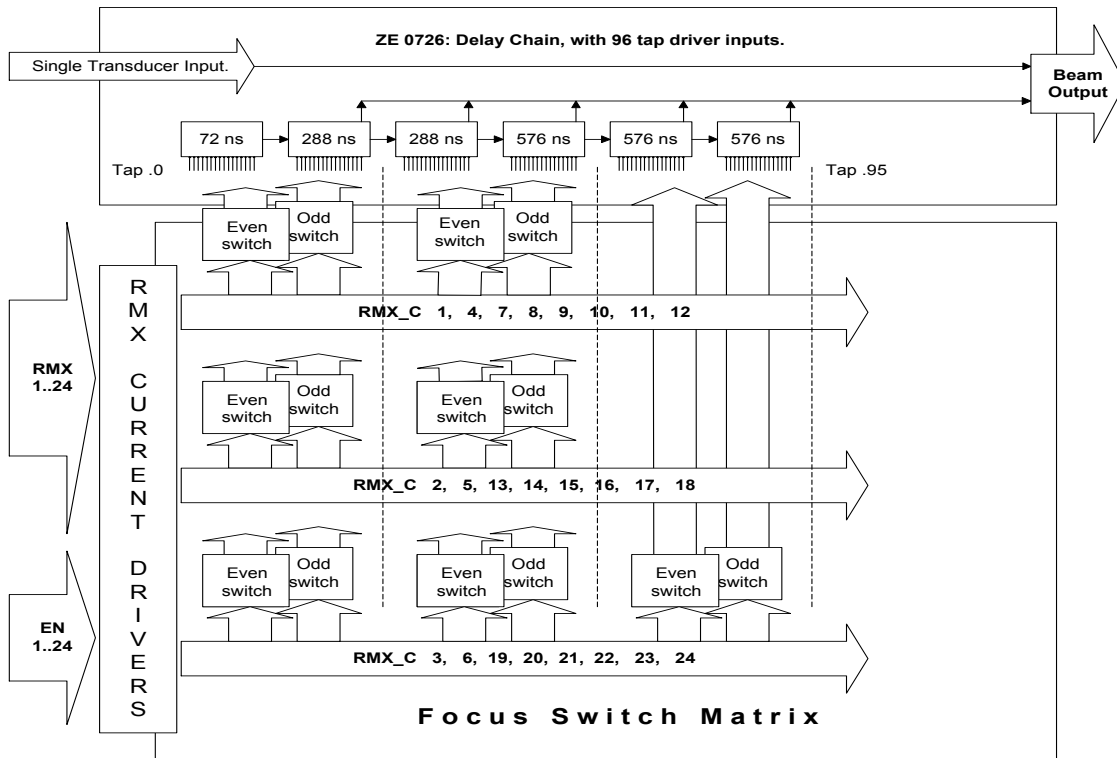

Fig. 8.3-3. 1101 focus switch matrix

Fig. 8.3-3 shows the 1101 focus switch matrix. The matrix has 16 inputs and connects to 96 input taps of the delay chain.

RMX 1 + 3 + 5 + 6...12: Range tap 0..63 (maximum: 1224 ns.).
 RMX 2 + 4 + 11...16: Range tap 0..63 (maximum: 1224 ns.).

The necessary delay range for the different RMX signals is lowest at the center aperture and highest at the edge of the aperture.

The advantages of the IAB concept:

- Only one chain of delay components is needed.
- As there are no zones and only one chain, no circuit matching is needed.
- The receive focus is close to ideal

Core board

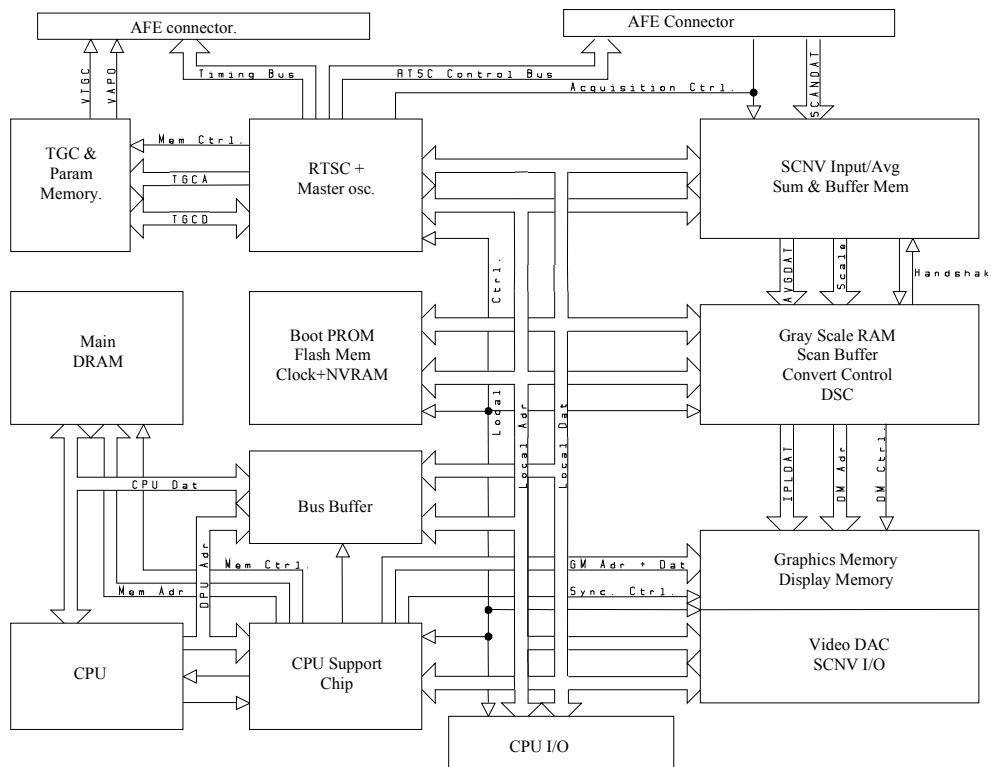

Fig. 8.3-4. Core Board

The Core board consists of three main blocks: CPU system, RTSC, and Scan Converter.

CPU system

This is a 386EX-based CPU system. It has two serial ports used for keyboard (Front panel) and debug terminal. Also embedded in the system is a Floppy disk controller, Memory system, Foot switch together with the Configuration switch register. The Graphics system which generates e.g. text and markers on the screen is also a part of this system.

Real-time Scancontroller (RTSC)

Contains the hardware for programming the Front End/Delay board and for generating all reference timing signals for acquisition of image data. It consists of the following modules: 120 MHz master oscillator, Sequencer, TCG/Parameter memory and Buffers/drivers for control busses.

The sequencer and control chip (FPGA) controls transmit and receive timing, data acquisition clocks and TGC/Parameter memory address generation.

Scanconverter

The SCNV part consists of the following modules:

- A/D converter for converting the beamformed signal to SCANDAT.
- Scan Line Pre-processing system which performs line averaging, assembling of composite focus lines, and Edge Enhancement (Contour).
- Image Averaging System which performs linear averaging of B-images, and handles image review (for all 2D images) and time review for M-mode
- Convert system for interpolation of scan lines to images and control of the display memory.
- Video DAC and rear panel connectors for video/audio.

The purpose of the Scanconverter and Display Subsystem is to convert the 2-D data from the Delay Board to video signals for use in the Monitor.

The data enters the Averaging system where the average of 1 to 14 images are generated. The averaged data is then stored in the Image Review memory image by image.

The scan lines from either the Averaging system (in record mode) or the Review Buffer (in review mode) are fed through a Grey Curve Mapping RAM and into the Scan Buffer.

The Converter Control is the device which generates the distance calculation between data samples in the scanlines and the pixel to be written to the Display Memory.

The converted data is stored in the Display Memory. There are two memory banks as the build-up of a converted image takes place in the background. When the image is converted, the banks are switched. Data from the active bank are clocked out from the VRAMs to a Video D/A converter/Palette circuit. Graphics from the CPU system are entered into the Video D/A converter as overlay to the image data.

Floppy Disk

The Floppy Disk Drive is not exactly a part of the Core, but the controller circuit is placed here. The drive is used for storing and retrieving ultrasound images and for updating the scanner software.

Single input module

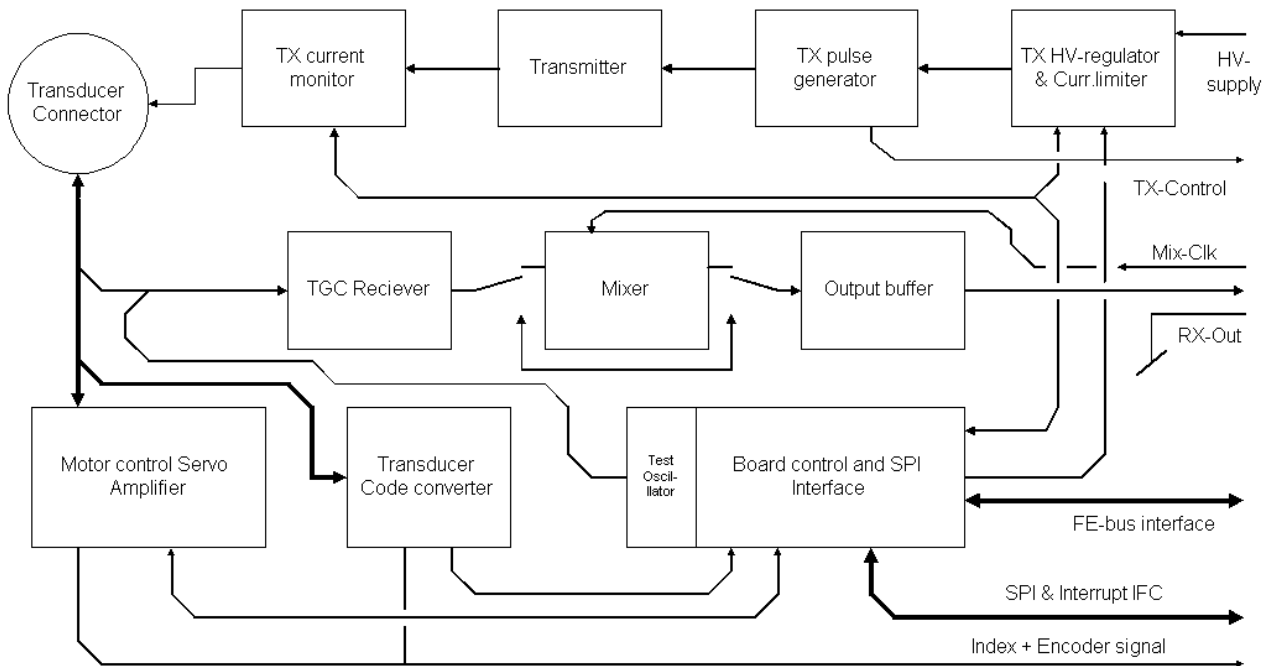

Fig. 8.3-5. Single input module

The Single input module is a self-contained functional block, with separate bus interface and board control, transmitter, receiver and motor control unit included. The transducer code interface circuit, which translate the discrete/analog single transducer codes to a serial data stream similar to the array transducer ID system, is included in the bus interface block.

The transmitter is special designed for the required frequency range.

The receiver front end is a TGC regulated wide-band preamplifier, which provides low input noise and performs all single channel TGC control. For frequencies = 12MHz, the receive signal from the preamplifier is transferred directly to the output stage (and then further processed in the beamformer circuitry). For the transducer frequencies between 15 and 20MHz, the signal passes through a down conversion path (a mixer circuit), which will downconvert the preamplified signals to a frequency inside the frequency range of the A/D converter in the beamformer, in order to prevent signal aliasing problems.

The output from the Single module is fed to the step variable amplifier block on the Front end/Delay board.

Power Supply

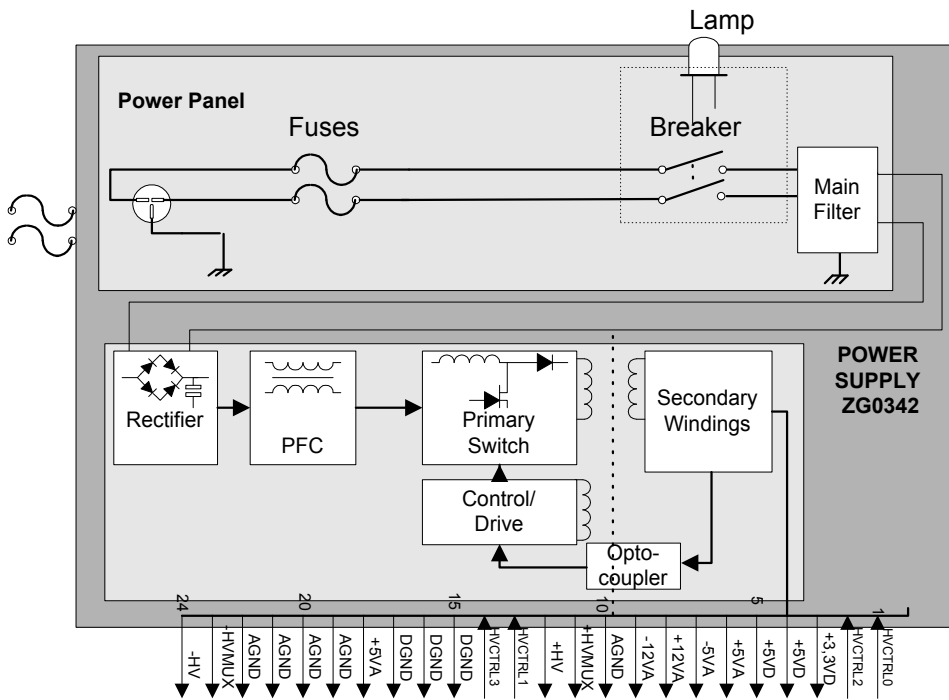

Fig. 8.3-6. Power Supply

The Switch mode Power Supply consist of a switch mode Power Supply which delivers: 3.3V, 5 V A, -5V A, +5V D, +12 V, +12V A, ±100V and one programmable HV supply (44-100V) controlled by the Core Board using 4 digital signals. The programmable output is used to drive the crystal elements of the transducers.

The DC outputs are protected against overload by current limiters.

The Power Supply can deliver a total DC output power of 160VA and is designed to run on a single mains phase of 115 volt or 230 volt AC. The Power Supply accepts voltages in the range 90-270V .The actual mains voltage/fuses needs **not** to be set .

Monitor

The 10" B/W monitor for the 1101 is a self contained unit, with standard video input signal. It operates at +12 V DC supplied directly by the power supply.

The horizontal scanning frequency is changed between 15.625 Hz (CCIR) and 15.750 Hz (EIA) automatically i.e. without adjustment of the unit. The vertical scanning frequency is 48-62 Hz (interlaced).

The monitors has external brightness and contrast controls.

1101 Test facilities

The 1101 tests are all visual tests creating an image on the monitor (refer to sec. 3 for details)

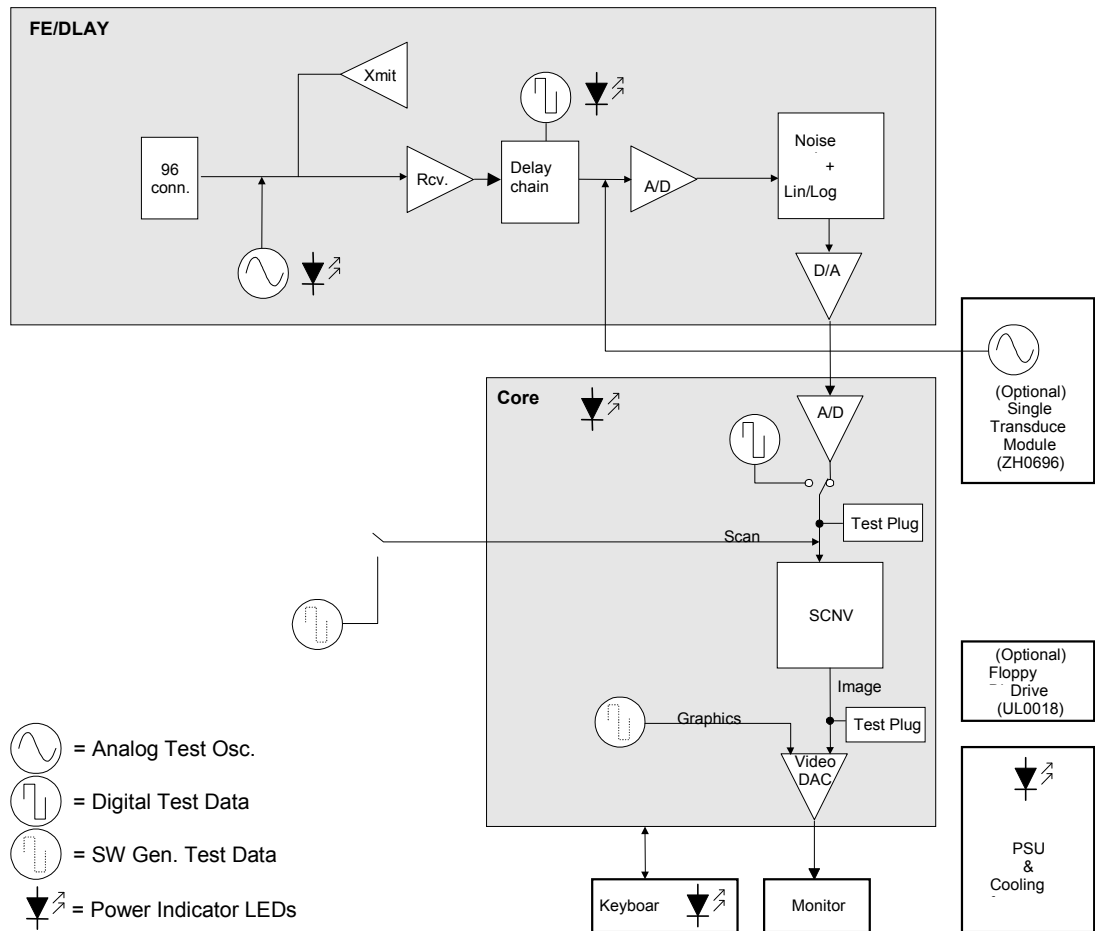

1101 Test Block

Fig. 8.3-7. Test Facilities in Ultrasound Scanner 1101

The Analog Front-End oscillator operates at 5.003 MHz and are connected to all 32 signal lines via small capacitors. The test is a verification of the receiver, delay and the scanconverter.

The delay part of the Front-End/Delay board has three test possibilities for generating test pictures on the monitor. Delay test 1 is a verification of the digital noise reduction system. The test signal is generated in a FPGA on the delay board.

Delay test 2 is a verification that all 32 channels from the Front-end/Delay board are active. Delay test 3 is a verification that all 16 inputs on the beamformer are working. Both Delay test 2 and 3 uses the Input test osc. for generating the test signal.

The Core board has a digital test oscillator for generating test pictures and a software “test oscillator” for setting up monitor test pictures.

Section 9**SYSTEM INTERCONNECTIONS**

CONTENTS	PAGE
9.1. Introduction	9-2
9.2. PCB Locations	9-2
9.3. Cable Connections (internal)	9-2
9.3.1. Identification Table	9-2
9.3.2. System Interconnection Diagram	9-3
9.4. Video specifications	9-4
9.5. Dip switch setting	9-5
9.6. Multi-pin Connections (external)	9-6

Introduction

By showing the PC Board locations, cables between PCB's, and external cable connections this section aims to help you keep track of important signals internally in the 1101 and to other equipment.

Further is described switch/jumper settings for quick reference.

PCB Locations

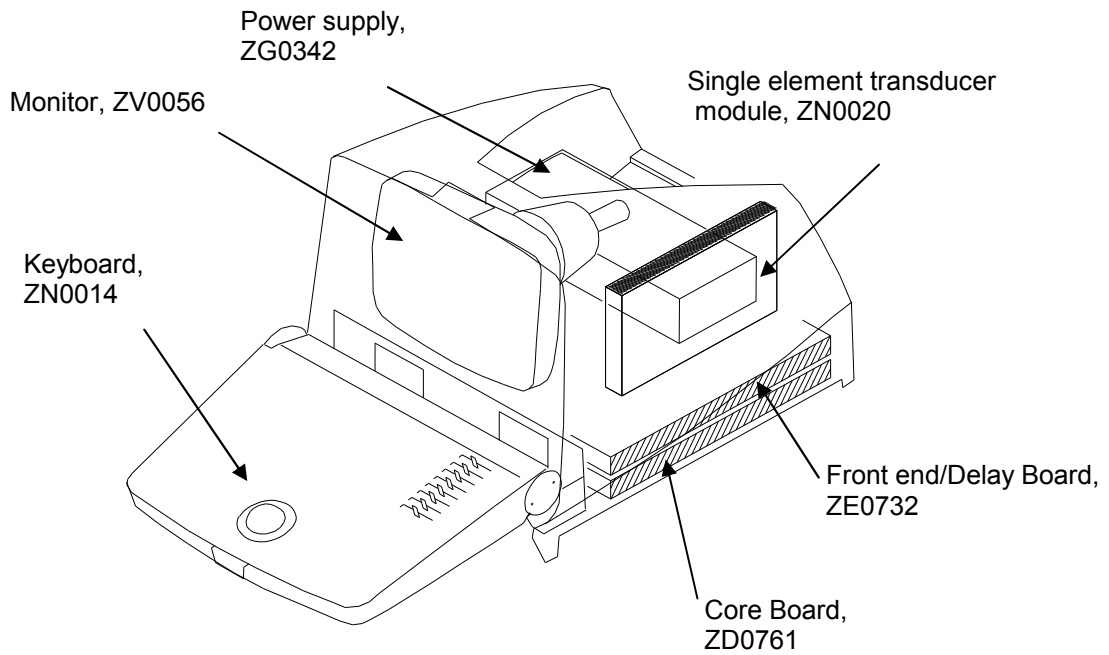

Fig 0-1 PCB Location

Cable Connections (internal)

The 1101 Interconnection diagram, figure 9.3-1, shows the cable connections between parts in the Merlin. To simplify the diagram all the cables are shown as single lines regardless of type and number of leads.

Identification Table

Cable no.	Type	No. of leads	Connecting
AQ1675	Ribbon	28	Single Module – Connector Board
AQ1674	Flexible	26	I/O board – Mother Board
AQ1671	Coax	4	Core board - Mother Board
AO2016	Single	6	Trackball – Potentiometer/Gain Board
AQ1673	Flexible	26	Floppy - Mother Board
AO0427	Single	8	Keyboard - Mother Board
AQ1677	Ribbon	50	Single Module - Mother Board

System Interconnection Diagram

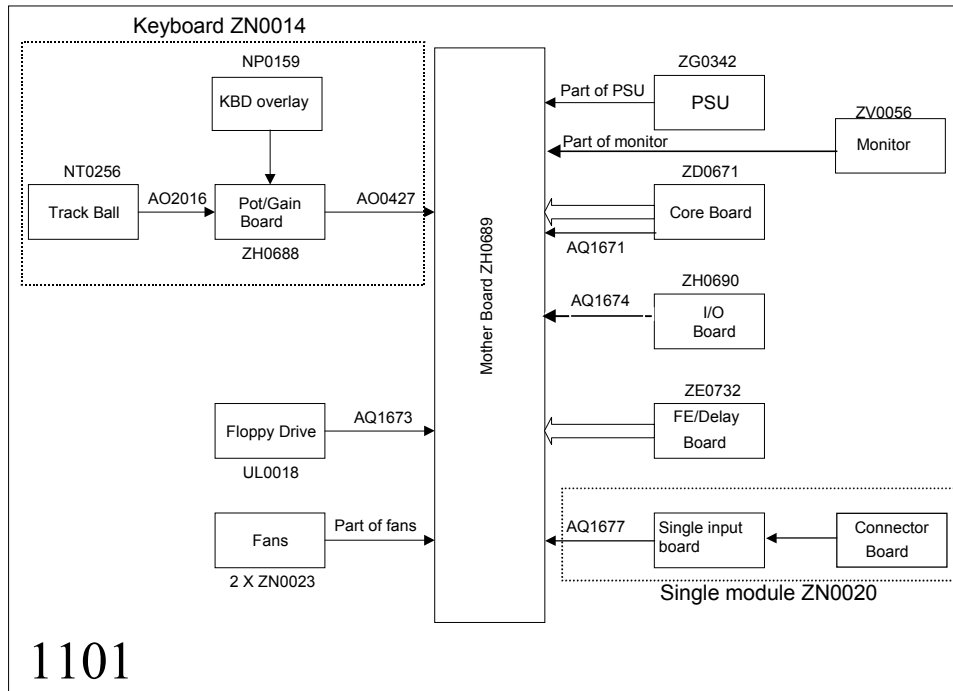

Fig. 0-1 System Interconnection Diagram

Video specifications

Scanning frequency:
 Horizontal: 15.625 Hz (CCIR) and 15.750 Hz (EIA)
 Vertical: 48-62 Hz interlaced.

Video frequency response:
 > 10 MHz +/-3 dB

Video input format:

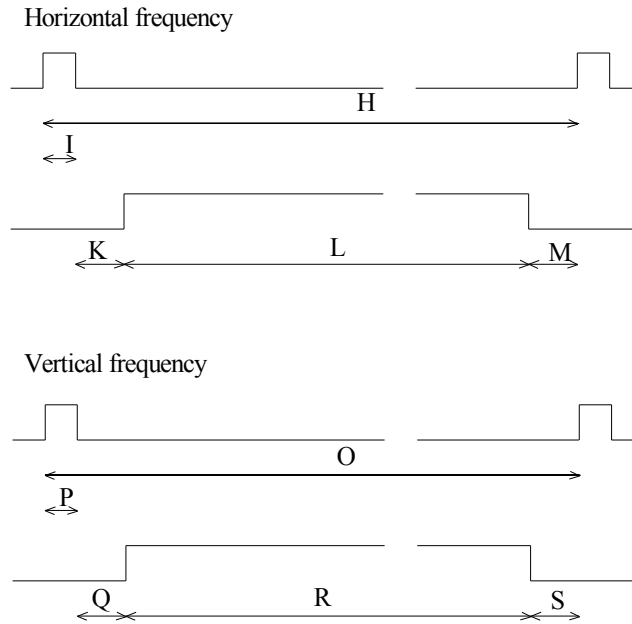

CCIR, 50 Hz

EIA, 60 Hz

H	64 μ sec = 960 pixel	63.5 μ sec = 768 pixel	
I		30 "	24 "
K		190 "	154 "
L		640 "	530 "
M		100 "	60 "
O		20 msec = 312.5 H	16.67 msec = 262.5 H
P	2.5+5+2.5 H = 10 H	2.5+5+2.5 = 10 H	
Q		38 H	28 H
R		240 H	200 H
S		34 H	24 H

Dip switch setting

Place the Scanner on the side to access the DIP switch underneath the scanner:

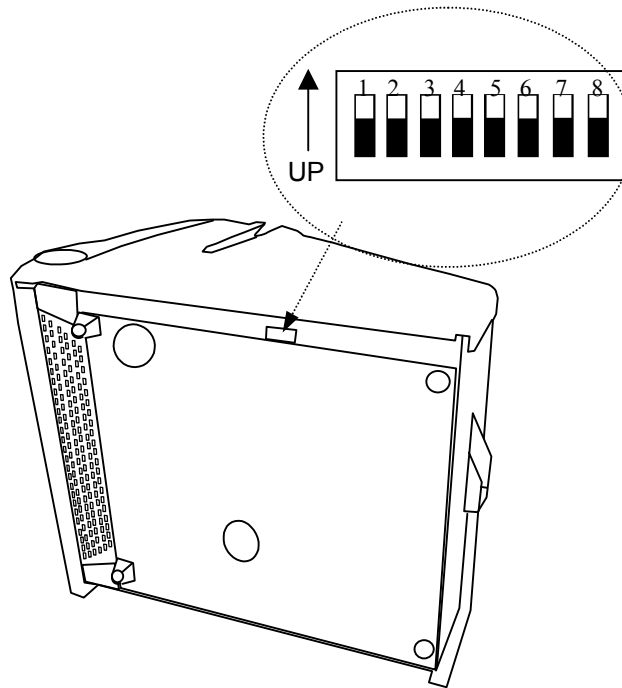

DIP switch, Default position = Up (Towards the edge of the scanner)

SW1 Up Down	Language User definable English
SW2 Up Down	RS232 A Standard Enhanced (Report using BKCOM program)
SW3 Up Down	TV Standard PAL NTSC
SW4	Not Used
SW5	Debug Com Port Com 1 (On the Back panel of the Scanner) Com 2 (Inside scanner)
SW6	Not Used
SW7	Not used
SW8 Up Down	Debug Terminal Off On (For reading of Error-Log)

Note! If Switch 1 is set to user definable then the language should be selected in the System setup menu, refer to the User Guide.

Multi-pin Connections (external)

The following section describes the multi-pin connectors situated on the rear of the 1101.

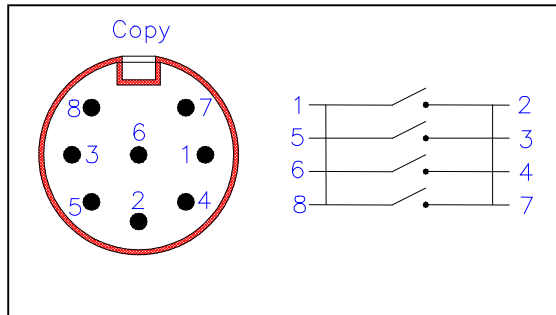

Fig. 0-1 Copy (Doc. trigger)

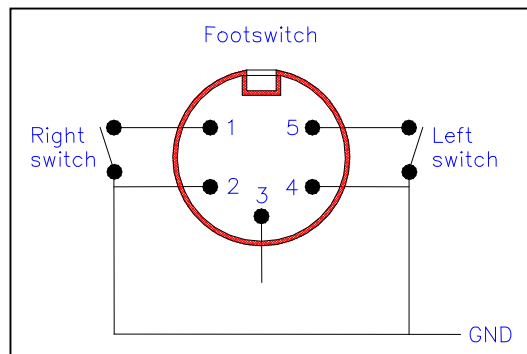

Fig. 0-2 Footswitch

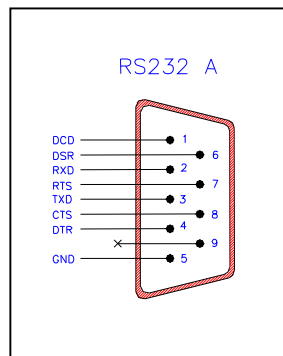

Fig. 0-4 Interface: RS232 A.