

GE

LOGIQ C Series

Basic Service Manual



Part Number: 5273008-100
Revision: 9

Important Precautions

**WARNING
(EN)**

THIS SERVICE MANUAL IS AVAILABLE IN ENGLISH ONLY.

- IF A CUSTOMER'S SERVICE PROVIDER REQUIRES A LANGUAGE OTHER THAN ENGLISH, IT IS THE CUSTOMER'S RESPONSIBILITY TO PROVIDE TRANSLATION SERVICES.
- DO NOT ATTEMPT TO SERVICE THE EQUIPMENT UNLESS THIS SERVICE MANUAL HAS BEEN CONSULTED AND IS UNDERSTOOD.
- FAILURE TO HEED THIS WARNING MAY RESULT IN INJURY TO THE SERVICE PROVIDER, OPERATOR OR PATIENT FROM ELECTRIC SHOCK, MECHANICAL OR OTHER HAZARDS.

**AVERTISSEMENT
(FR)**

CE MANUEL DE MAINTENANCE N'EST DISPONIBLE QU'EN ANGLAIS.

- SI LE TECHNICIEN DU CLIENT A BESOIN DE CE MANUEL DANS UNE AUTRE LANGUE QUE L'ANGLAIS, C'EST AU CLIENT QU'IL INCOMBE DE LE FAIRE TRADUIRE.
- NE PAS TENTER D'INTERVENTION SUR LES ÉQUIPEMENTS TANT QUE LE MANUEL SERVICE N'A PAS ÉTÉ CONSULTÉ ET COMPRIS.
- LE NON-RESPECT DE CET AVERTISSEMENT PEUT ENTRAÎNER CHEZ LE TECHNICIEN, L'OPÉRATEUR OU LE PATIENT DES BLESSURES DUES À DES DANGERS ÉLECTRIQUES, MÉCANIQUES OU AUTRES.

**WARNUNG
(DE)**

DIESES KUNDENDIENST-HANDBUCH EXISTIERT NUR IN ENGLISCHER SPRACHE.

- FALLS EIN FREMDER KUNDENDIENST EINE ANDERE SPRACHE BENÖTIGT, IST ES AUFGABE DES KUNDEN FÜR EINE ENTSPRECHENDE ÜBERSETZUNG ZU SORGEN.
- VERSUCHEN SIE NICHT, DAS GERÄT ZU REPARIEREN, BEVOR DIESES KUNDENDIENST-HANDBUCH NICHT ZU RATE GEZOGEN UND VERSTANDEN WURDE.
- WIRD DIESE WARNUNG NICHT BEACHTET, SO KANN ES ZU VERLETZUNGEN DES KUNDENDIENSTTECHNIKERS, DES BEDIENERS ODER DES PATIENTEN DURCH ELEKTRISCHE SCHLÄGE, MECHANISCHE ODER SONSTIGE GEFAHREN KOMMEN.

ESTE MANUAL DE SERVICIO SÓ LO EXISTE EN INGLÉS.

**AVISO
(ES)**

- SI ALGÚN PROVEEDOR DE SERVICIOS AJENO A GEHC SOLICITA UN IDIOMA QUE NO SEA EL INGLÉS, ES RESPONSABILIDAD DEL CLIENTE OFRECER UN SERVICIO DE TRADUCCIÓN.
- NO SE DEBERÁ DAR SERVICIO TÉCNICO AL EQUIPO, SIN HABER CONSULTADO Y COMPRENDIDO ESTE MANUAL DE SERVICIO.
- LA NO OBSERVANCIA DEL PRESENTE AVISO PUEDE DAR LUGAR A QUE EL PROVEEDOR DE SERVICIOS, EL OPERADOR O EL PACIENTE SUFRAN LESIONES PROVOCADAS POR CAUSAS ELÉCTRICAS, MECÁNICAS O DE OTRA NATURALEZA.

ESTE MANUAL DE ASSISTÊNCIA TÉCNICA SÓ SE ENCONTRA DISPONÍVEL EM INGLÊS.

**ATENÇÃO
(PT-Br)**

- SE QUALQUER OUTRO SERVIÇO DE ASSISTÊNCIA TÉCNICA, QUE NÃO A GEHC, SOLICITAR ESTES MANUAIS NOUTRO IDIOMA, É DA RESPONSABILIDADE DO CLIENTE FORNECER OS SERVIÇOS DE TRADUÇÃO.
- NÃO TENHA TENTADO REPARAR O EQUIPAMENTO SEM TER CONSULTADO E COMPREENDIDO ESTE MANUAL DE ASSISTÊNCIA TÉCNICA.
- O NÃO CUMPRIMENTO DESTA AVISO PODE POR EM PERIGO A SEGURANÇA DO TÉCNICO, OPERADOR OU PACIENTE DEVIDO A CHOQUES ELÉTRICOS, MECÂNICOS OU OUTROS.

ESTE MANUAL DE ASSISTÊNCIA ESTÁ DISPONÍVEL APENAS EM INGLÊS.

**AVISO
(PT-pt)**

- SE QUALQUER OUTRO SERVIÇO DE ASSISTÊNCIA TÉCNICA, QUE NÃO A GEHC, SOLICITAR ESTES MANUAIS NOUTRO IDIOMA, É DA RESPONSABILIDADE DO CLIENTE FORNECER OS SERVIÇOS DE TRADUÇÃO.
- NÃO TENHA EFECTUADO REPARAÇÕES NO EQUIPAMENTO SEM TER CONSULTADO E COMPREENDIDO PREVIAMENTE ESTE MANUAL.
- A INOBSERVÂNCIA DESTA AVISO PODE RESULTAR EM FERIMENTOS NO TÉCNICO DE ASSISTÊNCIA, OPERADOR OU PACIENTE EM CONSEQUÊNCIA DE CHOQUE ELÉTRICO, PERIGOS DE ORIGEM MECÂNICA, BEM COMO DE OUTROS TIPOS.

IL PRESENTE MANUALE DI MANUTENZIONE È DISPONIBILE SOLTANTO IN INGLESE.

**AVVERTENZA
(IT)**

- SE UN ADDETTO ALLA MANUTENZIONE ESTERNO ALLA GEHC RICHIEDE IL MANUALE IN UNA LINGUA DIVERSA, IL CLIENTE È TENUTO A PROVVEDERE DIRETTAMENTE ALLA TRADUZIONE.
- SI PROCEDA ALLA MANUTENZIONE DELL'APPARECCHIATURA SOLO DOPO AVER CONSULTATO IL PRESENTE MANUALE ED AVERNE COMPRESO IL CONTENUTO.
- NON TENERE CONTO DELLA PRESENTE AVVERTENZA POTREBBE FAR COMPIERE OPERAZIONI DA CUI DERIVINO LESIONI ALL'ADDETTO ALLA MANUTENZIONE, ALL'UTILIZZATORE ED AL PAZIENTE PER FOLGORAZIONE ELETTRICA, PER URTI MECCANICI OD ALTRI RISCHI.

HOIATUS
(ET)

KÄESOLEV TEENINDUSJUHEK ON SAADAVAL AINULT INGLISE KEELES.

- **KUI KLIENDITEENINDUSE OSUTAJA Nõ UAB JUHENDIT INGLISE KEELEST ERINEVAS KEELES, VASTUTAB KLIENT Tõ LKETEENUSE OSUTAMISE EEST.**
- **ä RGE üRITAGE SEADMEID TEENINDADA ENNE EELNEVALT Kä ESOLEVA TEENINDUSJUHEKIGA TUTVUMIST JA SELLEST ARU SAAMIST.**
- **Kä ESOLEVA HOIATUSE EIRAMINE Võ IB Põ HJUSTADA TEENUSEOSUTAJA, OPERAATORI Võ I PATSIENDI VIGASTAMIST ELEKTRILõ ö GI, MEHAANILISE Võ I MUU OHU TAGAJä RJEL.**

VAROITUS
(FI)

TÄMÄ HUOLTO-OHJE ON SAATAVILLA VAIN ENGLANNIKSI.

- **JOS ASIAKKAAN PALVELUNTARJOAJA VAATII MUUTA KUIN ENGLANNINKIELISTä MATERIAALIA, TARVITTAVAN Kä ä NNö KSEN HANKKIMINEN ON ASIAKKAAN VASTUULLA.**
- **ä Lä YRITä KORJATA LAITTEISTOA ENNEN KUIN OLET VARMASTI LUKENUT JA YMMä RTä NYT Tä Mä N HUOLTO-OHJEEN.**
- **MIKä LI Tä Tä VAROITUSTA EI NOUDATETA, SEURAUKSENA VOI OLLA PALVELUNTARJOAJAN, LAITTEISTON Kä YTTä Jä N TAI POTILAAN VAHINGOITTUMINEN Sä HKö ISKUN, MEKAANISEN VIAN TAI MUUN VAARATILANTEEN VUOKSI.**

ΠΡΟΕΙΔΟΠΟΙΗΣΗ
(EL)

ΤΟ ΠΑΡΟΝ ΕΓΧΕΙΡΙΔΙΟ ΣΕΡΒΙΣ ΔΙΑΤΙΘΕΤΑΙ ΣΤΑ ΑΓΓΛΙΚΑ ΜΟΝΟ.

- **ΕΑΝ ΤΟ ΑΤΟΜΟ ΠΑΡΟΧΗΣ ΣΕΡΒΙΣ ΕΝΟΣ ΠΕΛΑΤΗ ΑΠΑΙΤΕΙ ΤΟ ΠΑΡΟΝ ΕΓΧΕΙΡΙΔΙΟ ΣΕ ΓΛΩΣΣΑ ΕΚΤΟΣ ΤΩΝ ΑΓΓΛΙΚΩΝ, ΑΠΟΤΕΛΕΙ ΕΥΘΥΝΗ ΤΟΥ ΠΕΛΑΤΗ ΝΑ ΠΑΡΕΧΕΙ ΥΠΗΡΕΣΙΕΣ ΜΕΤΑΦΡΑΣΗΣ.**
- **ΜΗΝ ΕΠΙΧΕΙΡΗΣΕΤΕ ΤΗΝ ΕΚΤΕΛΕΣΗ ΕΡΓΑΣΙΩΝ ΣΕΡΒΙΣ ΣΤΟΝ ΕΞΟΠΛΙΣΜΟ ΕΚΤΟΣ ΕΑΝ ΕΧΕΤΕ ΣΥΜΒΟΥΛΕΥΤΕΙ ΚΑΙ ΕΧΕΤΕ ΚΑΤΑΝΟΗΣΕΙ ΤΟ ΠΑΡΟΝ ΕΓΧΕΙΡΙΔΙΟ ΣΕΡΒΙΣ.**
- **ΕΑΝ ΔΕ ΛΑΒΕΤΕ ΥΠΟΨΗ ΤΗΝ ΠΡΟΕΙΔΟΠΟΙΗΣΗ ΑΥΤΗ, ΕΝΔΕΧΕΤΑΙ ΝΑ ΠΡΟΚΛΗΘΕΙ ΤΡΑΥΜΑΤΙΣΜΟΣ ΣΤΟ ΑΤΟΜΟ ΠΑΡΟΧΗΣ ΣΕΡΒΙΣ, ΣΤΟ ΧΕΙΡΙΣΤΗ Ή ΣΤΟΝ ΑΣΘΕΝΗ ΑΠΟ ΗΛΕΚΤΡΟΠΛΗΞΙΑ, ΜΗΧΑΝΙΚΟΥΣ Ή ΑΛΛΟΥΣ ΚΙΝΔΥΝΟΥΣ.**

FIGYELMEZTETÉS
(HU)

EZEN KARBANTARTÁSI KÉZIKÖNYV KIZÁRÓLAG ANGOL NYELVEN ÉRHETŐ EL.

- **HA A VEVŐ SZOLGÁLTATÓJA ANGOLTÓL ELTÉRŐ NYELVRE TART IGÉNYT, AKKOR A VEVŐ FELELŐSSÉGE A FORDÍTÁS ELKÉSZÍTTETÉSE.**
- **NE PRÓBÁLJA ELKEZDENI HASZNÁLNI A BERENDEZÉST, AMÍG A KARBANTARTÁSI KÉZIKÖNYVBEN LEÍRTAKAT NEM ÉRTELMEZTÉK.**
- **EZEN FIGYELMEZTETÉS FIGYELMEN KÍVÜL HAGYÁSA A SZOLGÁLTATÓ, MŰKÖDTETŐ VAGY A BETEG ÁRAMÜTÉS, MECHANIKAI VAGY EGYÉB VESZÉLYHELYZET MIATTI SÉRÜLÉSÉT EREDMÉNYEZHETI.**

**VIÐVÖRUN
(IS)**

ÞESSI ÞJÓNUSTUHANDBÓK ER EINGÖNGU FÁANLEG Á ENSKU.

- EF ÞJÓNUSTUADILI VIÐSKIPTAMANNS ÞARFNAST ANNARS TUNGUMÁLS EN ENSKU, ER ÞAÐ Á ÁBYRGÐ VIÐSKIPTAMANNS AÐ ÚTVEGA ÞÝÐINGU.
- REYNIÐ EKKI AÐ ÞJÓNUSTA TÆKIÐ NEMA EFTIR AÐ HAFA SKOÐAÐ OG SKILIÐ ÞESSA ÞJÓNUSTUHANDBÓK.
- EF EKKI ER FARIÐ AÐ ÞESSARI VIÐVÖRUN GETUR ÞAÐ VALDIÐ MEIÐSLUM ÞJÓNUSTUVEITANDA, STJÓRNANDA EÐA SJÚKLINGS VEGNA RAFLOSTS, VÉLRÆNNAR EÐA ANNARRAR HÆTTU.

**VÝSTRAHA
(CS)**

TENTO SERVISNÍ NÁVOD EXISTUJE POUZE V ANGLICKÉM JAZYCE.

- V PŘÍPADĚ, ŽE POSKYTOVATEL SLUŽEB ZÁKAZNÍKŮM POTŘEBUJE NÁVOD V JINÉM JAZYCE, JE ZAJIŠTĚNÍ PŘEKLADU DO ODPOVÍDAJÍCÍHO JAZYKA ÚKOLEM ZÁKAZNÍKA.
- NEPROVÁDĚJTE ÚDRŽBU TOHOTO ZAŘÍZENÍ, ANIŽ BYSTE SI PŘEČETLI TENTO SERVISNÍ NÁVOD A POCHOPILI JEHO OBSAH.
- V PŘÍPADĚ NEDODRŽOVÁNÍ TĚTO VÝSTRAHY MŮŽE DOJÍT ÚRAZU ELEKTRICKÁM PROUDEM PRACOVNÍKA POSKYTOVATELE SLUŽEB, OBSLUŽNÉHO PERSONÁLU NEBO PACIENTŮ VLIVEM ELEKTRICKÉHO PROUDU, RESPEKTIVE VLIVEM K RIZIKU MECHANICKÉHO POŠKOZENÍ NEBO JINÉMU RIZIKU.

**ADVARSEL
(DA)**

DENNE SERVICEMANUAL FINDES KUN PÅ ENGELSK.

- HVIS EN KUNDES TEKNIKER HAR BRUG FOR ET ANDET SPROG END ENGELSK, ER DET KUNDENS ANSVAR AT SØRGE FOR OVERSÆTTELSE.
- FØRSØG IKKE AT SERVICERE UDSTYRET MEDMINDRE DENNE SERVICEMANUAL ER BLEVET LÆST OG FORSTÅET.
- MANGLENDE OVERHOLDELSE AF DENNE ADVARSEL KAN MEDFØRE SKADE PÅ GRUND AF ELEKTRISK, MEKANISK ELLER ANDEN FARE FOR TEKNIKEREN, OPERATØREN ELLER PATIENTEN.

**WAARSCHUWING
(NL)**

DEZE ONDERHOUDSHANDLEIDING IS ENKEL IN HET ENGELS VERKRIJGBAAR.

- ALS HET ONDERHOUDSPERSONEEL EEN ANDERE TAAL VEREIST, DAN IS DE KLANT VERANTWOORDELIJK VOOR DE VERTALING ERVAN.
- PROBEER DE APPARATUUR NIET TE ONDERHOUDEN VOORDAT DEZE ONDERHOUDSHANDLEIDING WERD GERAADPLEEGD EN BEGREPEN IS.
- INDIEN DEZE WAARSCHUWING NIET WORDT OPGEVOLGD, ZOU HET ONDERHOUDSPERSONEEL, DE OPERATOR OF EEN PATIËNT GEWOND KUNNEN RAKEN ALS GEVOLG VAN EEN ELEKTRISCHE SCHOK, MECHANISCHE OF ANDERE GEVAREN.

**BRĪDINĀJUMS
(LV)**

ŠĪ APKALPES ROKASGRĀMATA IR PIEEJAMA TIKAI ANĢĻU VALODĀ.

- JA KLIENTA APKALPES SNIEDZĒJAM NEPIECIEŠAMA INFORMĀCIJA CITĀ VALODĀ, NEVIS ANĢĻU, KLIENTA PIENĀKUMS IR NODROŠINĀT TULKOŠANU.
- NEVEICIET APRĪKOJUMA APKALPI BEZ APKALPES ROKASGRĀMATAS IZLASĪŠANAS UN SAPRAŠANAS.
- ŠĪ BRĪDINĀJUMA NEIEVĒROŠANA VAR RADĪT ELEKTRISKĀS STRĀVAS TRIECIENA, MEHĀNISKU VAI CITU RISKU IZRAISĪTU TRAUMU APKALPES SNIEDZĒJAM, OPERATORAM VAI PACIENTAM.

**ĮSPĖJIMAS
(LT)**

ŠIS EKSPLOATAVIMO VADOVAS YRA IŠLEISTAS TIK ANĢĻŲ KALBA.

- JEI KLIENTO PASLAUGŲ TEIKĖJUI REIKIA VADOVO KITA KALBA – NE ANĢĻŲ, VERTIMU PASIRŪPINTI TURI KLIENTAS.
- NEMĖGINKITE ATLIKTI ĮRANGOS TECHNINĖS PRIEŽIŪROS DARBŲ, NEBENT VADOVAUTUMĖTĖS ŠIUO EKSPLOATAVIMO VADOVU IR JĮ SUPRĀSTUMĖTE
- NEPAISANT ŠIO PERSPĖJIMO, PASLAUGŲ TEIKĖJAS, OPERATORIUS AR PACIENTAS GALI BŪTI SUŽEISTAS DĖL ELEKTROS SMŪGIO, MECHANINIŲ AR KITŲ PAVOJŲ.

**ADVARSEL
(NO)**

DENNE SERVICEHÅNDBOKEN FINNES BARE PÅ ENGELSK.

- HVIS KUNDENS SERVICELEVERANDØR TRENGER ET ANNET SPRÅK, ER DET KUNDENS ANSVAR Å SØRGE FOR OVERSETTELSE.
- IKKE FORSØK Å REPARERE UTSTYRET UTEN AT DENNE SERVICEHÅNDBOKEN ER LEST OG FORSTÅTT.
- MANGLENDE HENSYN TIL DENNE ADVARSELEN KAN FØRE TIL AT SERVICELEVERANDØREN, OPERATØREN ELLER PASIENTEN SKADES PÅ GRUNN AV ELEKTRISK STØT, MEKANISKE ELLER ANDRE FARER.

**OSTRZEŻENIE
(PL)**

NINIEJSZY PODRĘCZNIK SERWISOWY DOSTĘPNY JEST JEDYNIEM W JĘZYKU ANGIELSKIM.

- JEŚLI FIRMA Ś WIADCZYŁA KLIENTOWI USŁUGI SERWISOWE WYMAGA UDOSTĘPNIENIA PODRĘCZNIKA W JĘZYKU INNYM NIŻ ANGIELSKI, OBOWIĄZEK ZAPEWNIENIA STOSOWNEGO TŁUMACZENIA SPOCZYWA NA KLIENCIE.
- NIE PRÓBUJĄC SERWISOWAĆ NINIEJSZEGO SPRZĘTU BEZ UPRZEDNIEGO ZAPOZNANIA SIĘ Z PODRĘCZNIKIEM SERWISOWYM.
- NIEZASTOSOWANIE SIĘ DO TEGO OSTRZEŻENIA MOŻE GROZIĆ OBRAŻENIAMI CIAŁA SERWISANTA, OPERATORA LUB PACJENTA W WYNIKU PORAŻENIA PRĄDEM, URAZU MECHANICZNEGO LUB INNEGO RODZAJU ZAGROŻEŃ.

ACEST MANUAL DE SERVICE ESTE DISPONIBIL NUMAI ÎN LIMBA ENGLEZĂ.

**ATENȚIE
(RO)**

- **DACĂ UN FURNIZOR DE SERVICII PENTRU CLIEȚI NECESITĂ O ALTĂ LIMBĂ DECÂT CEA ENGLEZĂ, ESTE DE DATORIA CLIENTULUI SĂ FURNIZEZE O TRADUCERE.**
- **NU ÎNCERCAȚI SĂ REPARAȚI ECHIPAMENTUL DECÂT ULTERIOR CONSULTĂRII ȘI ÎNȚELEGERII ACESTUI MANUAL DE SERVICE.**
- **IGNORAREA ACESTUI AVERTISMENT AR PUTEA DUCE LA RĂNIREA DEPARATORULUI, OPERATORULUI SAU PACIENTULUI ÎN URMA PERICOLELOR DE ELECTROCUTARE, MECANICE SAU DE ALTĂ NATURĂ.**

Данное руководство по обслуживанию ПРЕДОСТАВЛЯЕТСЯ только на английском языке.

**ОСТОРОЖНО!
(RU)**

- **Если сервисному ПЕРСОНАЛУ клиента необходимо руководство не на английском языке, клиенту следует самостоятельно ОБЕСПЕЧИТЬ перевод.**
- **ПЕРЕД ОБСЛУЖИВАНИЕМ ОБОРУДОВАНИЯ ОБЯЗАТЕЛЬНО ОБРАТИТЕСЬ К ДАННОМУ РУКОВОДСТВУ И ПОЙМИТЕ ИЗЛОЖЕННЫЕ В НЕМ СВЕДЕНИЯ.**
- **НЕСОБЛЮДЕНИЕ УКАЗАННЫХ ТРЕБОВАНИЙ МОЖЕТ ПРИВЕСТИ К ТОМУ, ЧТО СПЕЦИАЛИСТ ПО ТЕХОБСЛУЖИВАНИЮ, ОПЕРАТОР ИЛИ ПАЦИЕНТ ПОЛУЧАТ УДАР ЭЛЕКТРИЧЕСКИМ ТОКОМ, МЕХАНИЧЕСКУЮ ТРАВМУ ИЛИ ДРУГОЕ ПОВРЕЖДЕНИЕ.**

ТОВА СЕРВИЗНО РЪКОВОДСТВО Е НАЛИЧНО САМО НА АНГЛИЙСКИ ЕЗИК.

**ПРЕДУПРЕЖДЕНИЕ
(BG)**

- **АКО ДОСТАВЧИКЪТ НА СЕРВИЗНИ УСЛУГИ НА КЛИЕНТ СЕ НУЖДАЕ ОТ ЕЗИК, РАЗЛИЧЕН ОТ АНГЛИЙСКИ, ЗАДЪЛЖЕНИЕ НА КЛИЕНТА Е ДА ПРЕДОСТАВИ ПРЕВОДАЧЕСКА УСЛУГА.**
- **НЕ СЕ ОПИТВАЙТЕ ДА ИЗВЪРШВАТЕ СЕРВИЗНО ОБСЛУЖВАНЕ НА ТОВА ОБОРУДВАНЕ, ОСВЕН ВСЛУЧАЙ, ЧЕ СЕРВИЗНОТО РЪКОВОДСТВО Е ПРОЧЕТЕНО И СЕ РАЗБИРА.**
- **НЕСПАЗВАНЕТО НА ТОВА ПРЕДУПРЕЖДЕНИЕ МОЖЕ ДА ДОВЕДЕ ДО НАРАНЯВАНЕ НА ДОСТАВЧИКА НА СЕРВИЗНИ УСЛУГИ, НА ОПЕРАТОРА ИЛИ ПАЦИЕНТА ВСЛЕДСТВИЕНА ТОКОВ УДАР, МЕХАНИЧНИ ИЛИ ДРУГИ РИСКОВЕ.**

OVAJ PRIRUČNIK ZA SERVISIRANJE DOSTUPAN JE SAMO NA ENGLJESKOM JEZIKU.

**UPOZORENJE
(SR)**

- **AKO KLIJENTOV SERVISER ZAHTJEVA JEZIK KOJI NIJE ENGLJESKI, ODGOVORNOST JE NA KLIJENTU DA PRUŽI USLUGE PREVOĐENJA.**
- **NEMOJTE POKUŠAVATI DA SERVISIRATE OPREMU AKO NISTE PROČITALI I RAZUMELI PRIRUČNIK ZA SERVISIRANJE.**
- **AKO NE POŠTUJETE OVO UPOZORENJE, MOŽE DOĆI DO POVREĐIVANJA SERVISERA, OPERATERA ILI PACIJENTA UZROKOVANOG ELEKTRIČNIM UDAROM, MEHANIČKIM I DRUGIM OPASNOSTIMA.**

TA SERVISNI PRIROČNIK JE NA VOLJO SAMO V ANGLEŠČINI.

**OPOZORILO
(SL)**

- ČE PONUDNIK SERVISNIH STORITEV ZA STRANKO POTREBUJE NAVODILA V DRUGEM JEZIKU, JE ZA PREVOD ODGOVORNA STRANKA SAMA.
- NE POSKUŠAJTE SERVISIRATI OPREME, NE DA BI PREJ PREBRALI IN RAZUMELI SERVISNI PRIROČNIK.
- ČE TEGA OPOZORILA NE UPOŠTEVATE, OBSTAJA NEVARNOST ELEKTRIČNEGA UDARA, MEHANSKIH ALI DRUGIH NEVARNOSTI IN POSLEDIČNIH POŠKODB PONUDNIKA SERVISNIH STORITEV, UPORABNIKA OPREME ALI PACIENTA.

OVAJ SERVISNI PRIRUČNIK DOSTUPAN JE SAMO NA ENGLJSKOM JEZIKU.

**UPOZORENJE
(HR)**

- AKO KLIJENTOV SERVISER ZAHTIJEVA JEZIK KOJI NIJE ENGLJSKI, ODGOVORNOST KLIJENTA JE PRUŽITI USLUGE PREVOĐENJA.
- NEMOJTE POKUŠAVATI SERVISIRATI OPREMU AKO NISTE PROČITALI I RAZUMJELI SERVISNI PRIRUČNIK.
- AKO NE POŠTUJETE OVO UPOZORENJE, MOŽE DOĆI DO OZLJEDE SERVISERA, OPERATERA ILI PACIJENTA PROUZROČENE STRUJNIM UDAROM, MEHANIČKIM I DRUGIM OPASNOSTIMA.

TÁTO SERVISNÁ PRÍRUČKA JE K DISPOZÍCII LEN V ANGLIČTINE.

**UPOZORNENIE
(SK)**

- AK ZÁKAZNÍKOV POSKYTOVATEĽ SLUŽIEB VYŽADUJE INÝ JAZYK AKO ANGLIČTINU, POSKYTNUTIE PREKLADATEĽSKÝCH SLUŽIEB JE ZODPOVEDNOSŤOU ZÁKAZNÍKA.
- NEPOKÚŠAJTE SA VYKONÁVAŤ SERVIS ZARIADENIA SKÔR, AKO SI NEPREČÍTATE SERVISNÚ PRÍRUČKU A NEPOROZUMIETE JEJ.
- ZANEDBANIE TOHTO UPOZORNENIA MÔŽE VYÚSTIŤ DO ZRANENIA POSKYTOVATEĽA SLUŽIEB, OBSLUHUJÚCEJ OSOBY ALEBO PACIENTA ELEKTRICKÝM PRÚDOM, PRÍPADNE DO MECHANICKÉHO ALEBO INÉHO NEBEZPEČENSTVA.

DEN HÄR SERVICEHANDBOKEN FINNS BARA TILLGÄNGLIG PÅ ENGELSKA.

**VARNING
(SV)**

- OM EN KUNDS SERVICETEKNIKER HAR BEHOV AV ETT ANNAT SPRÅK ÄN ENGELSKA ANSVARAR KUNDEN FÖR ATT TILLHANDAHÅLLA ÖVERSÄTTNINGSTJÄNSTER.
- FÖRSÖK INTE UTFÖRA SERVICE PÅ UTRUSTNINGEN OM DU INTE HAR LÄST OCH FÖRSTÅR DEN HÄR SERVICEHANDBOKEN.
- OM DU INTE TAR HÄNSYN TILL DEN HÄR VARNINGEN KAN DET RESULTERA I SKADOR PÅ SERVICETEKNIKERN, OPERATÖREN ELLER PATIENTEN TILL FÖLJD AV ELEKTRISKA STÖTAR, MEKANISKA FAROR ELLER ANDRA FAROR.

DİKKAT
(TR)

BU SERVİS KILAVUZU YALNIZCA İNGİLİZCE OLARAK SAĞLANMIŞTIR.

- EĞER MÜŞTERİ TEKNİSYENİ KILAVUZUN İNGİLİZCE DIŞINDAKİ BİR DİLDE OLMASINI İSTERSE, KILAVUZU TERCÜME ETTİRMEK MÜŞTERİNİN SORUMLULUĞUNDADIR.
- SERVİS KILAVUZUNU OKUYUP ANLAMADAN EKİPMANLARA MÜDAHALE ETMEYİNİZ.
- BU UYARININ GÖZ ARDI EDİLMESİ, ELEKTRİK ÇARPMASI YA DA MEKANİK VEYA DİĞER TÜRDE KAZALAR SONUCUNDA TEKNİSYENİN, OPERATÖRÜN YA DA HASTANIN YARALANMASINA YOL AÇABİLİR.

このサービスマニュアルには英語版しかありません。

GEHC 以外でサービスを担当される業者が英語以外の言語を要求される場合、翻訳作業はその業者の責任で行うものとさせていただきます。

警告
(JA)

このサービスマニュアルを熟読し理解せずに、装置のサービスを行わないで下さい。

この警告に従わない場合、サービスを担当される方、操作員あるいは患者さんが、感電や機械的又はその他の危険により負傷する可能性があります。

本服務手冊僅提供英文版。

- 如顧客之服務提供者需要英文版以外之語言，顧客需自行負擔其翻譯服務之責任。
- 在查閱並了解本服務手冊之內容前，請勿試圖維修本設備。
- 未確實遵守本警告，可能導致服務提供者、操作者或病患遭受電擊、機械危險或其他傷害。

警告
(繁體中文)
Traditional
Chinese

注意：
(ZH-CN)

本维修手册仅存有英文本。
非 GEMS 公司的维修员要求非英文本的维修手册时，
客户需自行负责翻译。
未详细阅读和完全了解本手册之前，不得进行维修。
忽略本注意事项会对维修员，操作员或病人造成触电，机械伤害或其他伤害。

경고
(KO)

- 본 서비스 지침서는 영어로만 이용하실 수 있습니다.
- 고객의 서비스 제공자가 영어이외 언어를 요구할 경우, 번역 서비스 지침서를 제공하는 것은 고객의 책임입니다.
- 본 서비스 지침서를 지침했고 이해하지 않는 한은 해당 장비를 수리를 시도하지 마십시오.
- 이 경우에 유해하지 않은 전기쇼크, 기계상의 혹은 다른 위험으로부터 서비스 제공자, 운영자 혹은 환자에게 위험을 가할 수 있습니다.

DAMAGE IN TRANSPORTATION

All packages should be closely examined at time of delivery. If damage is apparent write "Damage In Shipment" on ALL copies of the freight or express bill BEFORE delivery is accepted or "signed for" by a GE representative or hospital receiving agent. Whether noted or concealed, damage MUST be reported to the carrier immediately upon discovery, or in any event, within 14 days after receipt, and the contents and containers held for inspection by the carrier. A transportation company will not pay a claim for damage if an inspection is not requested within this 14 day period.

CERTIFIED ELECTRICAL CONTRACTOR STATEMENT - FOR USA ONLY

All electrical Installations that are preliminary to positioning of the equipment at the site prepared for the equipment shall be performed by licensed electrical contractors. Other connections between pieces of electrical equipment, calibrations and testing shall be performed by qualified GE personnel. In performing all electrical work on these products, GE will use its own specially trained field engineers. All of GE's electrical work on these products will comply with the requirements of the applicable electrical codes.

The purchaser of GE equipment shall only utilize qualified personnel (i.e., GE's field engineers, personnel of third-party service companies with equivalent training, or licensed electricians) to perform electrical servicing on the equipment.

OMISSIONS & ERRORS

If there are any omissions, errors or suggestions for improving this documentation, please contact the GE Global Documentation Group with specific information listing the system type, manual title, part number, revision number, page number and suggestion details.

Mail the information to:

Service Documentation,
GE Medical Systems (China) Co., Ltd.
No.19 Changjiang Road
WuXi National Hi-Tech Development Zone
Jiangsu, P.R China 214028
TEL: +86 510 85225888; FAX: +86 510 85226688

GE Healthcare employees should use TrackWise to report service documentation issues. These issues will then be in the internal problem reporting tool and communicated to the writer.

SERVICE SAFETY CONSIDERATIONS

 **DANGER DANGEROUS VOLTAGES, CAPABLE OF CAUSING DEATH, ARE PRESENT IN THIS EQUIPMENT. USE EXTREME CAUTION WHEN HANDLING, TESTING AND ADJUSTING.**

 **WARNING Use all Personal Protection Equipment (PPE) such as gloves, safety shoes, safety glasses, and kneeling pad, to reduce the risk of injury.**

For a complete review of all safety requirements, see the Chapter 1, Safety Considerations section in the Service Manual.

LEGAL NOTES

The contents of this publication may not be copied or duplicated in any form, in whole or in part, without prior written permission of GE.

GE may revise this publication from time to time without written notice.

PROPRIETARY TO GE

Permission to use this Advanced Service Software and related documentation (herein called the material) by persons other than GE employees is provided only under an Advanced Service Package License relating specifically to this Proprietary Material. This is a different agreement from the one under which operating and basic service software is licensed. A license to use operating or basic service software does not extend to or cover this software or related documentation.

If you are a GE employee or a customer who has entered into such a license agreement with GE to use this proprietary software, you are authorized to use this Material according to the conditions stated in your license agreement.

However, you do not have the permission of GE to alter, decompose or reverse-assemble the software, and unless you are a GE employee, you MAY NOT COPY the Material. The Material is protected by Copyright and Trade Secret laws; the violation of which can result in civil damages and criminal prosecution.

If you are not party to such a license agreement or a GE Employee, you must exit this Material now.

TRADEMARKS

All products and their name brands are trademarks of their respective holders.

COPYRIGHTS

All Material Copyright© 2008 - 2014 by General Electric Company Inc. All Rights Reserved.

Revision History

Revision	Date	Reason for change
1	June 10,2008	Initial Release
2	October 20,2008	Add new spare parts in Chapter 9
3	January 21,2009	Add CKD information
4	February 02,2010	Update Korean Rating Plate
5	May 22,2010	Update the procedure for unpacking the equipment in Chapter 3
6	July 13,2010	Update Label Locations information in Chapter 1
7	June 14 ,2010	Add keyboard lamp usage information in chapter 6
8	December 05,2012	Update environmental labels and add new spare parts
9	August 05,2014	Update the spare parts

List of Effected Pages(LOEP)

Pages	Revision	Pages	Revision	Pages	Revision
Title Page	9	Chapter 3 -System Setup pages 3-1 to 3-22	9	Chapter 8 - Replacement Procedures pages 8-1 to 8-6	9
Important Precautions pages i to x	9	Chapter 4 - Functional Checks pages 4-1 to 4-36	9	Chapter 9 - Replacement Parts pages 9-1 to 9-8	9
Table of Contents pages i to x	9	Chapter 5 - Theory pages 5-1 to 5-4	9	Chapter 10 - Periodic Maintenance pages 10-1 to 10-22	9
Chapter 1 - Introduction pages 1-1 to 1-12	9	Chapter 6 - Service Adjustments pages 6-1 to 6-2	9	Index pages I to II	9
Chapter 2 - Site Preparation pages 2-1 to 2-10	9	Chapter 7 - Diagnostics/ Troubleshooting pages 7-1 to 7-14	9	Back Cover	9

Table of Contents

CHAPTER 1

Introduction

Overview	1 - 1
Purpose of Chapter 1	1 - 1
Purpose of Service Manual	1 - 1
Typical Users of the Basic Service Manual	1 - 2
Purpose of Operator Manual(s)	1 - 2
LOGIQ C2/C3/C5 Models covered by this manual	1 - 2
Important Conventions	1 - 4
Conventions Used in Book	1 - 4
Standard Hazard Icons	1 - 5
Product Icons	1 - 5
Safety Considerations	1 - 6
Introduction	1 - 6
Human Safety	1 - 6
Mechanical Safety	1 - 6
Electrical Safety	1 - 7
Label Locations	1 - 7
Dangerous Procedure Warnings	1 - 8
Returning/Shipping Probes and Repair Parts	1 - 8
EMC, EMI, and ESD	1 - 9
Electromagnetic Compatibility (EMC)	1 - 9
CE Compliance	1 - 9
Electrostatic Discharge (ESD) Prevention	1 - 9
Customer Assistance	1 - 10
Contact Information	1 - 10
System Manufacturer	1 - 11
Factory Site	1 - 11

CHAPTER 2

Site Preparations

Overview	2 - 1
Purpose of chapter 2	2 - 1
General Console Requirements.	2 - 2
Console Environmental Requirements	2 - 2
Electrical Requirements	2 - 2
EMI Limitations	2 - 4
Scan Probe Environmental Requirements	2 - 5
Facility Needs	2 - 6
Purchaser Responsibilities	2 - 6
Required Features	2 - 7
Recommended and Alternate Ultrasound Room Layout	2 - 8
Networking Pre-installation Requirements	2 - 9

CHAPTER 3

System Setup

Overview	3 - 1
Purpose of Chapter 3	3 - 1
Setup Reminders	3 - 2
Average Installation Time	3 - 2
Installation Warnings	3 - 3
Safety Reminders	3 - 4
Receiving and Unpacking the Equipment.	3 - 5
Moving into Position	3 - 6
Product Locator Installation Card	3 - 6
Preparing for Installation.	3 - 7
Verify Customer Order	3 - 7
Physical Inspection	3 - 7
EMI Protection	3 - 7
Completing the Installation	3 - 8
Power On / Boot Up	3 - 8
Power Off/ Shutdown	3 - 8
Transducer Connection	3 - 9
System Configuration	3 - 10
System Specifications	3 - 10
Electrical Specifications	3 - 10
On-Board Optional Peripherals	3 - 11
Connecting Cables	3 - 12
Peripherals/Accessories Connector Panel	3 - 12
Available Probes	3 - 18
Software/Option Configuration	3 - 18
Connectivity Installation Worksheet	3 - 19
Loading Base Image Software	3 - 20
Software Version check out	3 - 21
Functional Check-out	3 - 21
Paperwork	3 - 22
Product Locator Installation	3 - 22
User Manual(s)	3 - 22

CHAPTER 4

Functional Checks

Overview	4 - 1
Purpose for Chapter 4	4 - 1
Required Equipment	4 - 1
General Procedure.	4 - 2
Power On/Boot Up	4 - 2
Power Off/ Shutdown	4 - 2
Archiving and Loading Presets	4 - 4
Adjusting the Display Monitor	4 - 5
System Features	4 - 6
B Mode Checks	4 - 9
M Mode Controls	4 - 12
Doppler Mode Checks	4 - 15
Color Flow Mode Checks	4 - 19
Basic Measurements	4 - 23
Probe/Connectors Usage	4 - 24
Using Cine	4 - 24
Image Management (QG)	4 - 25
Backup and Restore Database, Preset Configurations and Images	4 - 26
Software Configuration Checks	4 - 35
Peripheral Checks	4 - 35

CHAPTER 5

Components and Functions (Theory)

Overview.....	5 - 1
Purpose of Chapter 5	5 - 1
Block Diagram	5 - 2
System Diagram	5 - 2
Software Diagram	5 - 3
Common Service Platform	5 - 4
Introduction	5 - 4

CHAPTER 6

Service Adjustments

Overview	6 - 1
Purpose of this chapter 6	6 - 1
Monitor Adjustments	6 - 2
Adjustments Procedures	6 - 2

CHAPTER 7

Diagnostics/Troubleshooting

- Overview 7 - 1
 - Purpose of Chapter 7 7 - 1
- Gathering Trouble Data 7 - 2
 - Overview 7 - 2
 - Collect Vital System Information 7 - 2
 - Collect a Trouble Image with Logs 7 - 3
- USB Quick Save 7 - 4
 - Overview 7 - 4
 - Check and Record the Print or Store Key Function 7 - 4
 - Setting the Print or Store Key to USB Quick Save 7 - 5
- Screen Captures 7 - 6
 - Check and Record the Store Key Function 7 - 6
 - Setting the Store Key to Screen Capture 7 - 6
 - Capturing a Screen 7 - 6
 - Reset the Store Key to Customer’s Functionality 7 - 8
- Common Diagnostics 7 - 9
 - Utilities 7 - 9
 - PC Diagnostics (Non-Interactive Tests) 7 - 10
 - PC Diagnostics (Interactive Tests) 7 - 11
 - Restart LOGIQ C Series After Diagnostics 7 - 11
- Network Configuration 7 - 12
 - Network Configuration 7 - 12

CHAPTER 8

Replacement Procedures

Overview	8 - 1
Purpose of Chapter 8	8 - 1
DISASSEMBLY/RE-ASSEMBLY.....	8 - 2
Warning and Caution	8 - 2
Air filter and Knob Screw (FRU No. 5030)	8 - 2
Loading Base Image Software.....	8 - 3

CHAPTER 9

Renewal Parts

Overview	9 - 1
Purpose of Chapter 9	9 - 1
List of Abbreviations	9 - 1
Renewal Parts Lists	9 - 2
Equipment Models Covered in this Chapter	9 - 2
Operator Console Assy	9 - 3
Keyboard Assy	9 - 3
Accessories and kits	9 - 4
Manuals	9 - 6
Probes	9 - 7

CHAPTER 10

Care & Maintenance

- Overview 10 - 1
 - Periodic Maintenance Inspections 10 - 1
 - Purpose of Chapter 10 10 - 1
- Why do Maintenance 10 - 2
 - Keeping Records 10 - 2
 - Quality Assurance 10 - 2
- Maintenance Task Schedule 10 - 2
 - How often should care & maintenance tasks be performed? 10 - 2
- Tools Required 10 - 4
 - Standard GE Tool Kit 10 - 4
 - Special Tools, Supplies and Equipment 10 - 6
 - Input Power 10 - 7
 - Cleaning 10 - 7
 - Physical Inspection 10 - 7
 - Outlet Test - Wiring Arrangement - USA & Canada 10 - 8
 - Grounding Continuity 10 - 9
 - Chassis Leakage Current Test 10 - 11
 - Isolated Patient Lead (Source) Leakage–Lead to Lead 10 - 14
 - Isolated Patient Lead (Sink) Leakage-Isolation Test 10 - 14
 - Probe Leakage Current Test 10 - 16
- When There's Too Much Leakage Current..... 10 - 20

Chapter 1

Introduction

Section 1-1 Overview

1-1-1 Purpose of Chapter 1

This chapter describes important issues related to safely servicing the LOGIQ C Series. The service provider must read and understand all the information presented in this manual before installing or servicing a unit.

Table 1-1 Contents in Chapter 1

Section	Description	Page Number
1-1	"Overview"	1-1
1-2	"Important Conventions"	1-4
1-3	"Safety Considerations"	1-6
1-4	"EMC, EMI, and ESD"	1-9
1-5	"Customer Assistance"	1-10

1-1-2 Purpose of Service Manual

This Service Manual provides installation and service information for the LOGIQ C Series and contains the following chapters:

- 1.) - **Introduction:** Contains a content summary and warnings.
- 2.) - **Site Preparations:** Contains pre-installation requirements for the LOGIQ C Series.
- 3.) - **System Setup:** Contains installation procedures.
- 4.) - **Functional Checks:** Contains functional checks that are recommended as part of the installation, or as required during servicing and periodic maintenance.
- 5.) - **Components and Functions (Theory):** Contains block diagrams and functional explanations of the electronics.
- 6.) - **Service Adjustments:** Contains instructions on how to make available adjustments to the LOGIQ C Series.
- 7.) - **Diagnostics/Troubleshooting:** Provides procedures for running diagnostic or related routines for the LOGIQ C Series.
- 8.) - **Replacement Procedures:** Provides disassembly procedures and reassembly procedures for all changeable Field Replaceable Units (FRU).
- 9.) - **Renewal Parts:** Contains a complete list of field replaceable parts for the LOGIQ C Series.
- 10.) - **Care & Maintenance:** Provides periodic maintenance procedures for the LOGIQ C Series.

1-1-3 Typical Users of the Basic Service Manual

- Service Personnel (installation, maintenance, etc.).
- Hospital's Service Personnel
- Contractors (Some parts of Chapter 2 - Site Preparation)

1-1-4 Purpose of Operator Manual(s)

The Operator Manual(s) should be fully read and understood before operating the LOGIQ C Series and also kept near the unit for quick reference.

NOTE: Probe information displayed on screen does not necessarily reflect the probes available on your ultrasound system. Please refer to the probe list for available probes and features.

1-1-5 LOGIQ C2/C3/C5 Models covered by this manual

Table 1-2 LOGIQ C2 Model Designations

Part Number	Description
5270586	LOGIQ C2 Console for Europe
5310386	LOGIQ C2 Console for China
5310387	LOGIQ C2 Pro Console for China
5262932	LOGIQ C2 Console for India
5310757	LOGIQ C2 Console for Argentina

Table 1-3 LOGIQ C3 Model Designations

Part Number	Description
5268906	LOGIQ C3 Console for Europe
5310388	LOGIQ C3 Console for China
5310389	LOGIQ C3 Pro Console for China
5265742	LOGIQ C3 Console for India
5315917	LOGIQ C3 Console (110V)
5316706	LOGIQ C3 Console for Korea
5310821	LOGIQ C3 Console for Argentina

1-1-5 LOGIQ C2/C3/C5 Models covered by this manual (cont'd)**Table 1-4 LOGIQ C3 Model Designations**

Part Number	Description
52711114	LOGIQ C5 Console for Europe
5310390	LOGIQ C5 Console for China
5310391	LOGIQ C5 Pro Console for China
5269046	LOGIQ C5 Console for India
5316707	LOGIQ C5 Console for Korea
5315918	LOGIQ C5 Console (110V)
5310823	LOGIQ C5 Console for Argentina
5391533	LOGIQ C5 3-Probe Console for China
5391534	LOGIQ C5 Pro 3-Probe Console for China
5391538	LOGIQ C5 3-Probe Console (110V)
5391536	LOGIQ C5 3-Probe Console for Argentina

Section 1-2 Important Conventions





1-2-1 Conventions Used in Book

Icons

Pictures, or icons, are used wherever they reinforce the printed message. The icons, labels and conventions used on the product and in the service information are described in this chapter.

Safety Precaution Messages

Various levels of safety precaution messages may be found on the equipment and in the service information. The different levels of concern are identified by a flag word that precedes the precautionary message. Known or potential hazards are labeled in one of following ways:







-  **DANGER** **DANGER IS USED TO INDICATE THE PRESENCE OF A HAZARD THAT WILL CAUSE SEVERE PERSONAL INJURY OR DEATH IF THE INSTRUCTIONS ARE IGNORED.**
-  **WARNING** **WARNING IS USED TO INDICATE THE PRESENCE OF A HAZARD THAT CAN CAUSE SEVERE PERSONAL INJURY AND PROPERTY DAMAGE IF INSTRUCTIONS ARE IGNORED.**
-  **CAUTION** **Caution is used to indicate the presence of a hazard that will or can cause minor personal injury and property damage if instructions are ignored.**
-  **NOTICE** **Equipment Damage Possible**
Notice is used when a hazard is present that can cause property damage but has absolutely no personal injury risk.
Example: Disk drive will crash.

NOTE: *Notes provide important information about an item or a procedure. Information contained in a NOTE can often save you time or effort.*

1-2-2 Standard Hazard Icons



Important information will always be preceded by the exclamation point contained within a triangle, as seen throughout this chapter. In addition to text, several different graphical icons (symbols) may be used to make you aware of specific types of hazards that could cause harm.

Table 1-5 Standard Hazard Icons

ELECTRICAL	MECHANICAL	RADIATION
		
LASER	HEAT	PINCH
		

Other hazard icons make you aware of specific procedures that should be followed.

Table 1-6 Standard Icons Indicating a Special Procedure Be Used

AVOID STATIC ELECTRICITY	TAG AND LOCK OUT	WEAR EYE PROTECTION
		

1-2-3 Product Icons

Please refer to User Manual (Basic user Manual/User Guide) for the detail Product Icons information.

Section 1-3 Safety Considerations

1-3-1 Introduction

The following safety precautions must be observed during all phases of operation, service and repair of this equipment. Failure to comply with these precautions or with specific warnings elsewhere in this manual, violates safety standards of design, manufacture and intended use of the equipment.

1-3-2 Human Safety

Servicing should be performed by authorized personnel only.

Only personnel who have participated in a LOGIQ C Series Training are authorized to service the equipment.

1-3-3 Mechanical Safety

 **WARNING** *WHEN THE UNIT IS RAISED FOR A REPAIR OR MOVED ALONG ANY INCLINE, USE EXTREME CAUTION SINCE IT MAY BECOME UNSTABLE AND TIP OVER.*

 **WARNING** *ULTRASOUND PROBES ARE HIGHLY SENSITIVE MEDICAL INSTRUMENTS THAT CAN EASILY BE DAMAGED BY IMPROPER HANDLING. USE CARE WHEN HANDLING AND PROTECT FROM DAMAGE WHEN NOT IN USE. DO NOT USE A DAMAGED OR DEFECTIVE PROBE. FAILURE TO FOLLOW THESE PRECAUTIONS CAN RESULT IN SERIOUS INJURY AND EQUIPMENT DAMAGE.*

 **WARNING** *NEVER USE A PROBE THAT HAS FALLEN TO THE FLOOR. EVEN IF IT LOOKS OK, IT MAY BE DAMAGED.*

 **CAUTION** The LOGIQ C Series weighs 75 kg or more, depending on installed peripherals, when ready for use. Care must be used when moving it or replacing its parts. Failure to follow the precautions listed could result in injury, uncontrolled motion and costly damage.



ALWAYS:

Be sure the pathway is clear.

Use slow, careful motions.

Use two people when moving on inclines or lifting more than 75 kg (169 lbs).

 **WARNING** *AFTER UNPLUG POWER CORD, WAIT FOR AT LEAST 20 SECONDS FOR CAPACITORS TO DISCHARGE AS THERE ARE NO TEST POINTS TO VERIFY ISOLATION.*

1-3-3 Mechanical Safety (cont'd)

NOTE: Special care should be taken when transporting the unit in a vehicle:

- Secure the unit in an upright position.
- Lock the wheels (brake)

1-3-4 Electrical Safety

To minimize shock hazard, the equipment chassis must be connected to an electrical ground. The system is equipped with a three-conductor AC power cable. This must be plugged into an approved electrical outlet with safety ground. The power outlet used for this equipment should not be shared with other types of equipment.

Both the system power cable and the power connector meet international electrical standards.









WARNING *DO NOT SERVICE OR DISASSEMBLE PARTS UNDER FRU UNIT LEVEL AT ANY CIRCUMSTANCES.*

1-3-5 Label Locations

See LC2/C2 PRO, LC3/LC3 PRO, LC5/C5PRO Basic User Manual (5265060-100,5268001-100,5268596-100) section "Warning Label Location" for more Information.

1-3-6 Dangerous Procedure Warnings

Warnings, such as the examples below, precede potentially dangerous procedures throughout this manual. Instructions contained in the warnings must be followed.

-  **DANGER** **DANGEROUS VOLTAGES, CAPABLE OF CAUSING DEATH, ARE PRESENT IN THIS EQUIPMENT. USE EXTREME CAUTION WHEN HANDLING, TESTING AND ADJUSTING.**
- 
-  **WARNING** **EXPLOSION WARNING**
DO NOT OPERATE THE EQUIPMENT IN AN EXPLOSIVE ATMOSPHERE. OPERATION OF ANY ELECTRICAL EQUIPMENT IN SUCH AN ENVIRONMENT CONSTITUTES A DEFINITE SAFETY HAZARD.
-  **WARNING** **DO NOT SUBSTITUTE PARTS OR MODIFY EQUIPMENT**
BECAUSE OF THE DANGER OF INTRODUCING ADDITIONAL HAZARDS, DO NOT INSTALL SUBSTITUTE PARTS OR PERFORM ANY UNAUTHORIZED MODIFICATION OF THE EQUIPMENT.
-  **WARNING** **SHUT DOWN FORCEDLY OR PLUG IN/OUT ACDC INVALID MAY CAUSE THE DAMAGE OF SYSTEM FILES.**
-  **WARNING** **AFTER UNPLUG POWER CORD, WAIT FOR AT LEAST 20 SECONDS FOR CAPACITORS TO DISCHARGE AS THERE ARE NO TEST POINTS TO VERIFY ISOLATION.**

1-3-7 Returning/Shipping Probes and Repair Parts

Equipment being returned must be clean and free of blood and other infectious substances.

GEMS policy states that body fluids must be properly removed from any part or equipment prior to shipment. GEMS employees, as well as customers, are responsible for ensuring that parts/equipment have been properly decontaminated prior to shipment. Under no circumstance should a part or equipment with visible body fluids be taken or shipped from a clinic or site (for example, body coils or an ultrasound probe).

The purpose of the regulation is to protect employees in the transportation industry, as well as the people who will receive or open this package.

NOTE: The USER/SERVICE staff should dispose all the waste properly as per federal, state, and local waste disposal regulation.

Section 1-4 EMC, EMI, and ESD

1-4-1 Electromagnetic Compatibility (EMC)

Electromagnetic compatibility describes a level of performance of a device within its electromagnetic environment. This environment consists of the device itself and its surroundings including other equipment, power sources and persons with which the device must interface. Inadequate compatibility results when a susceptible device fails to perform as intended due to interference from its environment or when the device produces unacceptable levels of emission to its environment. This interference is often referred to as radio-frequency or electromagnetic interference (RFI/EMI) and can be radiated through space or conducted over interconnecting power or signal cables. In addition to electromagnetic energy, EMC also includes possible effects from electrical fields, magnetic fields, electrostatic discharge and disturbances in the electrical power supply.

1-4-2 CE Compliance

The LOGIQ C Series unit conforms to all applicable conducted and radiated emission limits and to immunity from electrostatic discharge, radiated and conducted RF fields, magnetic fields and power line transient requirements.

For applicable standards refer to the Safety Chapter in the Basic User Manual.

NOTE: For CE Compliance, it is critical that all covers, screws, shielding, gaskets, mesh, clamps, are in good condition, installed tightly without skew or stress. Proper installation following all comments noted in this service manual is required in order to achieve full EMC performance.

1-4-3 Electrostatic Discharge (ESD) Prevention



WARNING

DO NOT TOUCH ANY BOARDS WITH INTEGRATED CIRCUITS PRIOR TO TAKING THE NECESSARY ESD PRECAUTIONS:

1. FOLLOW GENERAL GUIDELINES FOR HANDLING OF ELECTROSTATIC SENSITIVE EQUIPMENT.



Section 1-5 Customer Assistance

1-5-1 Contact Information

If this equipment does not work as indicated in this service manual or in the User Manual, or if you require additional assistance, please contact the local distributor or appropriate support resource, as listed below.

Prepare the following information before you call:

- System ID serial number.
- Software version.

Table 1-7 Phone Numbers for Customer Assistance

Location	Phone Number	
USA GE Vingmed Ultrasound Ultrasound Service Engineering 9900 Innovation Drive Wauwatosa, WI 53226	Service: On-site	1-800-437-1171
	Service Parts	1-800-558-2040
	Application Support	1-800-682-5327 or 1-262-524-5698
Canada		1-800-668-0732
Latin America	Service	1-800-321-7937
	Application Support	1-262-524-5698
Europe (OLC- EMEA) GE Ultraschall Deutschland GmbH Beethovenstraße 239 Postfach 11 05 60, D-42655 Solingen Germany	OLC - EMEA Phone: +49 (0)212 2802 - 652 +33 1 3083 1300 Fax: +49 (0) 212 2802 - 431	
Online Services Ultrasound Asia Australia China India Japan Korea Singapore	Phone: +(61) 1-800-647-855 +(86) 800-810-8188 +(91) 1-800-11-4567 +(81) 42-648-2924 +(82) 2620 13585 +(95) 6277-3444	

1-5-2 System Manufacturer**Table 1-8 System Manufacturer**

Manufacturer	FAX Number
GE Medical Systems (China) Co., Ltd. No.19, Changjiang Road, Wuxi National Hi-Tech Development Zone, Jiangsu, P.R. China 214028	TEL: +86 510-85225888 FAX: +86 510-85226688

1-5-3 Factory Site**Table 1-9 Factory Site**

Factory Site	FAX Number
GE Medical Systems (China) Co., Ltd. No.19, Changjiang Road, Wuxi National Hi-Tech Development Zone, Jiangsu, P.R. China 214028	TEL: +86 510-85225888 FAX: +86 510-85226688
Wirpo GE Healthcare Pvt. Ltd., No. 4, Kadugodi Industrial Area, Bangalore. 560067 Karnataka. India.	TEL: +91-80-41801000 FAX: +91-80-28452924

This page was intentionally left blank.

Chapter 2

Site Preparations

Section 2-1 Overview

2-1-1 Purpose of chapter 2

This chapter provides the information required to plan and prepare for the installation of LOGIQ C Series. Included are descriptions of the facility and electrical needs to be met by the purchaser of the unit.

Table 2-1 Contents in Chapter 2

Section	Description	Page Number
2-1	"Overview"	2-1
2-2	"General Console Requirements"	2-2
2-3	"Facility Needs"	2-6

Section 2-2 General Console Requirements

2-2-1 Console Environmental Requirements

Table 2-2 Environmental Requirements for LOGIQ C Series Scanners

	Operational	Storage	Transport
Temperature	10 - 40°C 50 - 104 °F	-5 - 50 °C 23 - 122°F	-5 - 50 °C 23 - 122°F
Humidity	30 - 75% non-condensing	10 - 90% non-condensing	10 - 90% non-condensing
Pressure	700 - 1060hPa	700 - 1060hPa	700 - 1060hPa

NOTE: Temperature in degrees C. Conversion to Degrees F = (Degrees C * 9/5) + 32.

2-2-1-1 Lighting

Bright light is needed for system installation, updates and repairs. However, operator and patient comfort may be optimized if the room light is subdued and indirect. Therefore a combination lighting system (dim/bright) is recommended. Keep in mind that lighting controls and dimmers can be a source of EMI which could degrade image quality. These controls should be selected to minimize possible interface.

2-2-2 Electrical Requirements

NOTE: GE Healthcare requires a dedicated power and ground for the proper operation of its Ultrasound equipment. This dedicated power shall originate at the last distribution panel before the system.

Sites with a mains power system with defined Neutral and Live:

The dedicated line shall consist of one phase, a neutral (not shared with any other circuit), and a full size ground wire from the distribution panel to the Ultrasound outlet.

Sites with a mains power system without a defined Neutral:

The dedicated line shall consist of one phase (two lines), not shared with any other circuit, and a full size ground wire from the distribution panel to the Ultrasound outlet.

NOTE: Please note that image artifacts can occur, if at any time within the facility, the ground from the main facility's incoming power source to the Ultrasound unit is only a conduit.

2-2-2 Electrical Requirements (cont'd)

2-2-2-1 LOGIQ C Series Power Requirements

The following power line parameters should be monitored for one week before installation. We recommend that you use an analyzer Dranetz Model 606-3 or Dranetz Model 626:

Table 2-3 Electrical Specifications for LOGIQ C Series

PARAMETER	AREA	LIMITS
Voltage Range	100-120V~	500VA
	220-240V~	500VA
Power	All applications	MAX. 750 VA
Line Frequency	All applications	50/60Hz (±2Hz)
Power Transients	All applications	Less than 25% of nominal peak voltage for less than 1 millisecond for any type of transient, including line frequency, synchronous, asynchronous, or aperiodic transients.
Decaying Oscillation	All applications	Less than 15% of peak voltage for less than 1 millisecond.

2-2-2-2 Inrush Current

Inrush Current is not a factor to consider due to the inrush current limiting properties of the power supplies.

2-2-2-3 Site Circuit Breaker

It is recommended that the branch circuit breaker for the machine be readily accessible.



CAUTION POWER OUTAGE MAY OCCURE.

The LOGIQ C Series requires a dedicated single branch circuit. To avoid circuit overload and possible loss of critical care equipment, make sure you DO NOT have any other equipment operating on the same circuit.

2-2-2-4 Site Power Outlets

A dedicated AC power outlet must be within reach of the unit without extension cords. Other outlets adequate for the external peripherals, medical and test equipment needed to support this unit must also be present within 1 m (3.2 ft.) of the unit. Electrical installation must meet all current local, state, and national electrical codes.

2-2-2-5 Unit Power Plug

If the unit arrives without the power plug, or with the wrong plug, you must contact your GE dealer or the installation engineer must supply what is locally required.

2-2-2-6 Power Stability Requirements

Voltage drop-out

Max 10 ms.

Power Transients

(All applications)

Less than 25% of nominal peak voltage for less than 1 millisecond for any type of transient, including line frequency, synchronous, asynchronous, or aperiodic transients.

2-2-3 EMI Limitations

Ultrasound machines are susceptible to Electromagnetic Interference (EMI) from radio frequencies, magnetic fields, and transient in the air wiring. They also generate EMI. The LOGIQ C Series complies with limits as stated on the EMC label. However there is no guarantee that interface will not occur in a particular installation.

Possible EMI sources should be identified before the unit is installed.

Electrical and electronic equipment may produce EMI unintentionally as the result of defect.

These sources include:

- medical lasers,
- scanners,
- cauterizing guns,
- computers,
- monitors,
- fans,
- gel warmers,
- microwave ovens,
- light dimmers,
- portable phones.

The presence of broadcast station or broadcast van may also cause interference. See for EMI Prevention tips.

See [Table 2-4](#) for EMI Prevention tips.

Table 2-4 EMI Prevention/abatement

EMI Rule	Details
Be aware of RF sources	Keep the unit at least 5 meters or 15 feet away from other EMI sources. Special shielding may be required to eliminate interference problems caused by high frequency, high powered radio or video broadcast signals.
Ground the unit	Poor grounding is the most likely reason a unit will have noisy images. Check grounding of the power cord and power outlet.
Replace all screws, RF gaskets, covers, cores	After you finish repairing or updating the system, replace all covers and tighten all screws. Any cable with an external connection requires a magnet wrap at each end. Install the shield over the front of card cage. Loose or missing covers or RF gaskets allow radio frequencies to interface with the ultrasound signals.
Replace broken RF gaskets	If more than 20% or a pair of fingers on the RF gaskets are broken, replace the gaskets. Do not turn on the unit until any loose metallic part is removed.
Do not place labels where RF gaskets touch metal	Never place a label where RF gaskets meet the unit. Otherwise, the gap created will permit RF leakage. Or, if a label has been found in such a position, move the label.
Use GE specified harnesses and peripherals	The interconnect cables are grounded and require ferrite beads and other shielding. Also, cable length, material, and routing are all important; do not change from what is specified.
Take care with cellular phones	Cellular phones may transmit a 5 V/m signal; that could cause image artifacts.
Properly dress peripheral cables	Do not allow cables to lie across the top of the card cage or hang out of the peripheral bays. Loop the excess length for peripheral cables inside the peripheral bays. Attach the monitor cables to the frame.

2-2-4 Scan Probe Environmental Requirements

Operation:10° to 40° C

Storage:-10° to 50° C

*NOTE: Temperature in degrees C. Conversion to Degrees F = (Degrees C * (9/5) + 32).*



NOTICE SYSTEMS AND ELECTRONIC PROBES ARE DESIGNED FOR STORAGE TEMPERATURES OF -10 TO + 60 degrees C. WHEN EXPOSED TO LARGE TEMPERATURE VARIATIONS, THE PRODUCT SHOULD BE KEPT IN ROOM TEMPERATURE FOR 10 HOURS BEFORE USE.

Section 2-3 Facility Needs

2-3-1 Purchaser Responsibilities

The work and materials needed to prepare the site is the responsibility of the purchaser. Delay, confusion, and waste of manpower can be avoided by completing pre installation work before delivery. Use the Pre Installation checklist to verify that all needed steps have been taken, Purchaser responsibility includes:

- Procuring the materials required.
- Completing the preparations before delivery of the ultrasound system.
- Paying the costs for any alternations and modifications not specifically provided in the sales contract.

NOTE: *All electrical installation that are preliminary to the positioning of the equipment at the site prepared for the equipment must be performed by licensed electrical contractors. Other connections between pieces of electrical equipment, products involved (and the accompanying electrical installations) are highly sophisticated and special engineering competence is required. All electrical work on these product must comply with the requirements of applicable electrical codes. The purchaser of GE equipment must only utilize qualified personnel to perform electrical servicing on the equipment.*

The desire to use a non-listed or customer provided product or to place an approved product further from the system than the interface kit allows presents challenges to the installation team. To avoid delays during installation, such variances should be made known to the individuals or group performing the installation at the earliest possible date (preferable prior to purchase).

The ultrasound suite must be clean proof to delivery of the machine. Carpet is not recommended because it collects dust and creates static. Potential sources of EMI (electromagnetic interference) should also be investigated before delivery. Dirt, static, and EMI can negatively impact system.

2-3-2 Required Features

NOTE: GE Medical Systems requires a dedicated power and ground for the proper operation of its Ultrasound equipment. This dedicated power shall originate at the last distribution panel before the system.

Sites with a mains power system with defined Neutral and Live:

The dedicated line shall consist of one phase, a neutral (not shared with any other circuit), and a full size ground wire from the distribution panel to the Ultrasound outlet.

Sites with a mains power system without a defined Neutral:

The dedicated line shall consist of one phase (two lines), not shared with any other circuit, and a full size ground wire from the distribution panel to the Ultrasound outlet.

Please note that image artifacts can occur, if at any time within the facility, the ground from the main facility's incoming power source to the Ultrasound unit is only a conduit.

- Dedicated single branch power outlet of adequate amperage meeting all local and national codes which is located less than 2.5 m (8 ft.) from the unit's proposed location
- Door opening is at least 76 cm (30 in) wide
- Proposed location for unit is at least 0.3 m (1 ft.) from the wall for cooling
- Power outlet and place for any external peripheral are within 2 m (6.5 ft.) of each other with peripheral within 1 m of the unit to connect cables.

2-3-3 Recommended and Alternate Ultrasound Room Layout

Recommended standard floor plan and a minimal floor plan for ultrasound equipment:

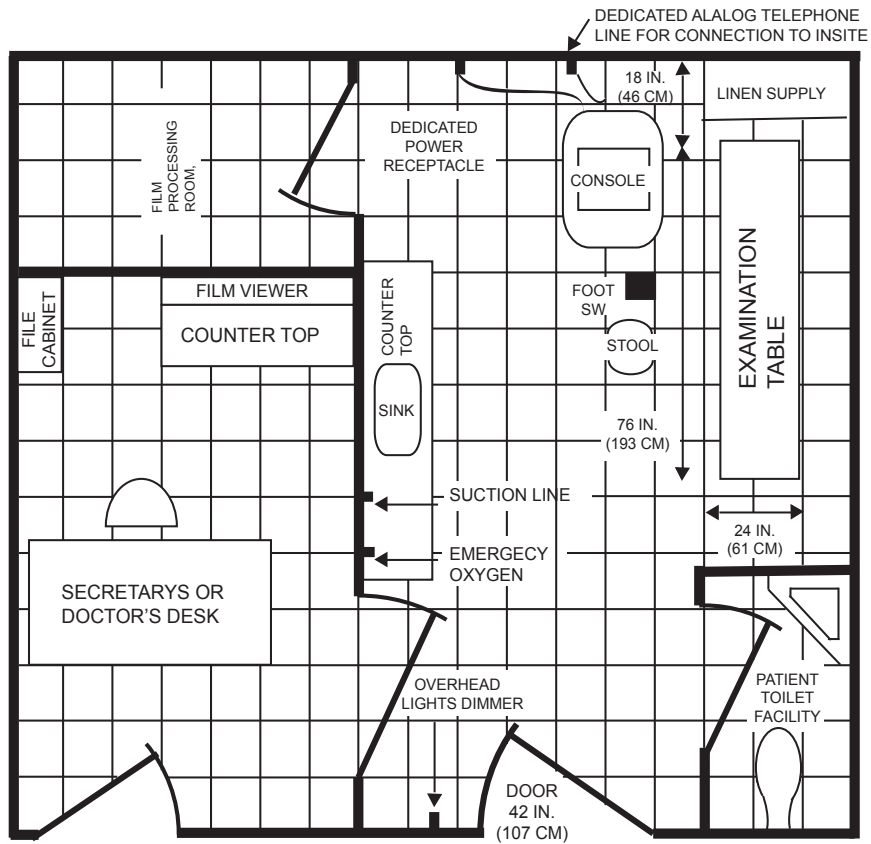

A 14 by 17 foot Recommended Floor Plan

Scale : Each square equals one square foot

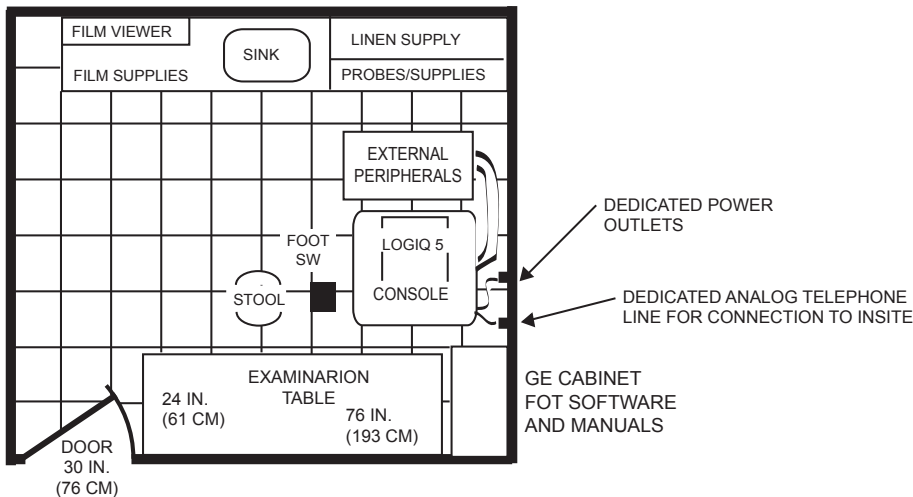

An 8 by 10 foot Minimal Floor Plan

Figure 2-1 RECOMMENDED ULTRASOUND ROOM LAYOUT

2-3-4 Networking Pre-installation Requirements

2-3-4-1 Stand Alone Scanner (without Network Connection)

None.

2-3-4-2 Scanner Connected to Hospital's Network

Supported networks:

Wire LAN

2-3-4-3 Purpose of DICOM Network Function

DICOM services provide the operator with clinically useful features for moving images and patient information over a hospital network. Examples of DICOM services include the transfer of images to workstations for viewing or transferring images to remote printers. As an added benefit, transferring images in this manner frees up the on-board monitor and peripherals, enabling viewing to be done while scanning continues. With DICOM, images can be archived, stored, and retrieved faster, easier, and at a lower cost.

2-3-4-4 DICOM Option Pre-installation Requirements

To configure the LOGIQ C Series to work with other network connections, the site's network administrator must provide some necessary information.

Information must include:

- A host name, local port number, AE Title, IP address and Net Mask for the LOGIQ C Series.
- The IP addresses for the default gateway and other routers at the site for ROUTING INFORMATION.
- The host name, IP address, port and AE Title for each device the site wants connected to the LOGIQ C Series for DICOM APPLICATION INFORMATION. A field for the make (manufacturer) and the revision of the device, is also included. This information may be useful for solving errors.

2-3-4-4 DICOM Option Pre-installation Requirements (cont'd)

LOGIQ C
 Host Name Local Port IP Address . . .
 AE Title Net Mask . . .

ROUTING INFORMATION

	Destination IP Addresses				GATEWAY IP Addresses				
					Default				
ROUTER1	<input type="text"/>	<input type="text"/>	<input type="text"/>	<input type="text"/>	<input type="text"/>	<input type="text"/>	<input type="text"/>	<input type="text"/>	<input type="text"/>
ROUTER2	<input type="text"/>	<input type="text"/>	<input type="text"/>	<input type="text"/>	<input type="text"/>	<input type="text"/>	<input type="text"/>	<input type="text"/>	<input type="text"/>
ROUTER3	<input type="text"/>	<input type="text"/>	<input type="text"/>	<input type="text"/>	<input type="text"/>	<input type="text"/>	<input type="text"/>	<input type="text"/>	<input type="text"/>

DICOM APPLICATION INFORMATION

	NAME	MAKE/REVISION	AE TITLE	IP ADDRESSES	PORT
Store 1	<input type="text"/>	<input type="text"/>	<input type="text"/>	<input type="text"/> . <input type="text"/> . <input type="text"/> . <input type="text"/>	<input type="text"/>
Store 2	<input type="text"/>	<input type="text"/>	<input type="text"/>	<input type="text"/> . <input type="text"/> . <input type="text"/> . <input type="text"/>	<input type="text"/>
Store 3	<input type="text"/>	<input type="text"/>	<input type="text"/>	<input type="text"/> . <input type="text"/> . <input type="text"/> . <input type="text"/>	<input type="text"/>
Store 4	<input type="text"/>	<input type="text"/>	<input type="text"/>	<input type="text"/> . <input type="text"/> . <input type="text"/> . <input type="text"/>	<input type="text"/>
Store 5	<input type="text"/>	<input type="text"/>	<input type="text"/>	<input type="text"/> . <input type="text"/> . <input type="text"/> . <input type="text"/>	<input type="text"/>
Store 6	<input type="text"/>	<input type="text"/>	<input type="text"/>	<input type="text"/> . <input type="text"/> . <input type="text"/> . <input type="text"/>	<input type="text"/>
Worklist	<input type="text"/>	<input type="text"/>	<input type="text"/>	<input type="text"/> . <input type="text"/> . <input type="text"/> . <input type="text"/>	<input type="text"/>
Storage Commit	<input type="text"/>	<input type="text"/>	<input type="text"/>	<input type="text"/> . <input type="text"/> . <input type="text"/> . <input type="text"/>	<input type="text"/>
MPPS	<input type="text"/>	<input type="text"/>	<input type="text"/>	<input type="text"/> . <input type="text"/> . <input type="text"/> . <input type="text"/>	<input type="text"/>

Figure 2-2 Worksheet for DICOM Network Information

Chapter 3

System Setup

Section 3-1 Overview

3-1-1 Purpose of Chapter 3

This chapter contains information needed to install the unit. Included are references to a procedure that describes how to receive and unpack the equipment and how to file a damage or loss claim. How to prepare the facility and unit of the actual installation, and how to check and test the unit and external peripherals for electrical safety are included in this procedure. Also included LOGIQ C Series in this section are guidelines for transporting the unit to a new site.

Table 3-1 Contents in Chapter 3

Section	Description	Page Number
3-1	"Overview"	3-1
3-2	"Setup Reminders"	3-2
3-3	"Receiving and Unpacking the Equipment"	3-3
3-4	"Preparing for Installation"	3-4
3-5	"Completing the Installation"	3-5
3-6	"System Configuration"	3-6
3-7	"Software/Option Configuration"	3-7
3-8	"Connectivity Installation Worksheet"	3-8
3-9	"Loading Base Image Software"	3-9
3-10	"Software Version check out"	3-10
3-11	"Paperwork"	3-11

Section 3-2 Setup Reminders

3-2-1 Average Installation Time

Table 3-2 Average Installation Time

Description	Average Installation Time	Comments
Unpacking the scanner	0.5 hour	
Scanner wo/options	0.5 hour	Dependant on the configuration that is required
DICOM Option	0.5 hour	Dependant on the amount of configuration

The LOGIQ C Series has been designed to be installed and checked out by an experienced service technician in approximately 1 hour. LOGIQ C Series consoles with optional equipment may take slightly longer.

3-2-2 Installation Warnings

- 1.) Since the LOGIQ C Series weighs approximately 75 kg without options, preferably two people should unpack it. Two people are also preferable for installing any additional bulky items.
- 2.) There are no operator serviceable components. To prevent shock, do not remove any covers or panels. Should problems or malfunctions occur, unplug the power cord. Only qualified service personnel should carry out servicing and troubleshooting.

NOTE: For information regarding packing labels, refer to LABELS ON PACKAGE.

- 3.) After being transported, the unit may be very cold or hot. If this is the case, allow the unit to acclimate before you turn it on. It requires one hour for each 2.5°C increment it's temperature is below 10°C or above 30°C.





CAUTION Equipment damage possibility. Turning the system on without acclimation after arriving at site may cause the system to be damaged.

Table 3-3 Acclimation Time

°C	60	55	50	45	40	35	30	25	20	15	10	5	0	-5	-10	-15	-20	-25	-30	-35	-40
°F	140	131	122	113	104	95	86	77	68	59	50	41	32	23	14	5	-4	-13	-22	-31	-40
hrs	8	6	4	2	0	0	0	0	0	0	0	2	4	6	8	10	12	14	16	18	20

3-2-3 Safety Reminders

-  **DANGER** **WHEN USING ANY TEST INSTRUMENT THAT IS CAPABLE OF OPENING THE AC GROUND LINE (I.E., METER'S GROUND SWITCH IS OPEN), DON'T TOUCH THE UNIT!**

-  **CAUTION** Two people should unpack the unit because of its weight. Two people are required whenever a part weighing 19kg (35 lb.) or more must be lifted.

-  **CAUTION** If the unit is very cold or hot, do not turn on its power until it has had a chance to acclimate to its operating environment.

-  **CAUTION** To prevent electrical shock, connect the unit to a properly grounded power outlet. Do not use a three to two prong adapter. This defeats safety grounding.

-  **CAUTION** Do NOT wear the ESD wrist strap when you work on live circuits and more than 30 V peak is present.

-  **CAUTION** Do not use a 20 Amp to 15 Amp adapter on the 120 Vac unit's power cord. This unit requires a dedicated 20 A circuit and can have a 15A plug if the on board peripherals do not cause the unit to draw more than 14.0 amps.

-  **CAUTION** Do not operate this unit unless all board covers and frame panels are securely in place. System performance and cooling require this.

-  **CAUTION** **OPERATOR MANUAL(S)**
The User Manual(s) should be fully read and understood before operating the LOGIQ C Series and kept near the unit for quick reference.

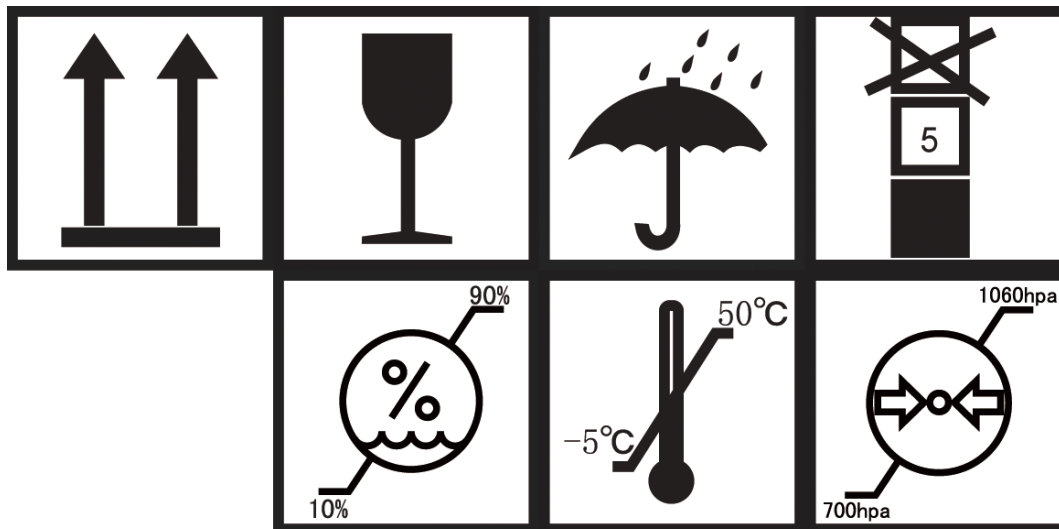

Figure 3-1 Environmental Labels

Section 3-3 Receiving and Unpacking the Equipment

When a new system arrives, check that any components are not damaged and are not in short supply. If shipping damage or shortage occurs, contact the address shown in Chapter 1.



CAUTION Do not lift the unit by the Keyboard. Equipment damage may result.



CAUTION The crate with the LOGIQ C Series weighs approximately 75kg. Be prepared for a sudden shift of weight as the unit is removed from its base (pallet)

Unpacking the the equipment

- 1.) Remove all the strapping tapes from the packing box.
- 2.) Remove the upper cover of the packing box and then rotate the knob to the right to open the packing box.
- 3.) Remove the PE bag and plastic film from the system.
- 4.) Remove Accessories Carton from the system.
- 5.) Remove the PE bag and plastic film from the syste
- 6.) Lift down the system .

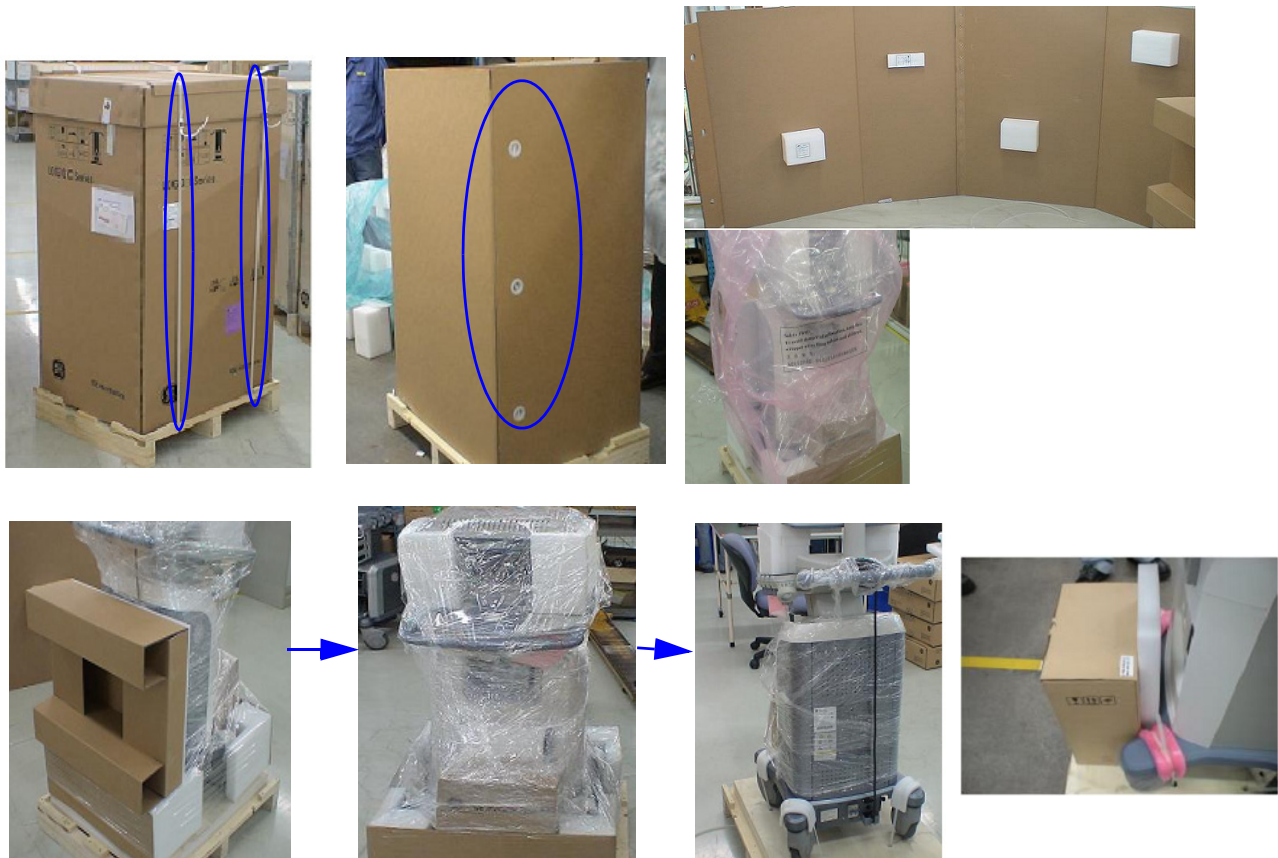

Figure 3-2 Open the box

3-3-1 Moving into Position

 **CAUTION** Do not tilt the unit more than 5 degrees to avoid tipping it over. To avoid injury by tipping over. Set the monitor to the lowest position before moving.

In general, a single adult can move the LOGIQ C Series along an even surface with no steep grades. At least two people should move the machine when large humps, grooves, or grades will be encountered. (It is better to pull from the rear rather than push from the front of the unit). Before moving, store all loose parts in the unit. Wrap transducers in soft cloth or foam to prevent damage.

Although LOGIQ C Series is a mobile machine, two people should move it over rough surfaces or up and down grades.

3-3-2 Product Locator Installation Card

NOTE: The Product Locator Installation Card shown may not be same as the provided Product Locator card.

	Mailing Address GE Medical Systems Product Locator File P.O. Box 414 Milwaukee, WI 53201-0414				
	PREPARE FOR ORDERS THAT DO NOT HAVE A LOCATOR INSTALLATION REPORT	DESCRIPTION SYSTEM ID NUMBER _____ _____ _____ _____	FDA MODEL OCP DIST.-COUNTRY CUSTOMER NO. DESTINATION - NAME AND ADDRESS _____ _____ _____ _____	REV SERIAL BS ROOM EMPLOYEE NO.	ORD DATE (MO-DA-YR) _____ _____ _____ _____
PRINTED IN USA INSTALLATION	INSTALLATION				ZIP CODE _____

Figure 3-3 Product Locator Installation Card

Section 3-4 Preparing for Installation

3-4-1 Verify Customer Order

Compare items received by the customer to that which is listed on the delivery order. Report any items that are missing, back ordered or damaged.

3-4-2 Physical Inspection

3-4-2-1 System Voltage Settings

Verify that Docking Cart is set to the correct voltage.

The Voltage settings for the LOGIQ C Series is found on a label to the right of the Power switch and External I/O, on the rear of the system.



WARNING *Connecting a LOGIQ C Series to the wrong voltage level will most likely destroy it.*

3-4-2-2 Video Formats

Check that the video format is set to the locally used video standard, NTSC or PAL.

3-4-3 EMI Protection

This Unit has been designed to minimize the effects of Electro Magnetic Interference (EMI). Many of the covers, shields, and screws are provided primarily to protect the system from image artifacts caused by this interference. For this reason, it is imperative that all covers and hardware are installed and secured before the unit is put into operation.

Section 3-5 Completing the Installation

3-5-1 Power On / Boot Up

NOTE: After turning off a system, wait at least ten seconds before turning it on again. The system may not be able to boot if power is recycled too quickly.

3-5-1-1 Scanner Power On

When power is applied to the scanner, power is distributed to the Cooling Unit, Control Panel, LCD, Peripherals and the Back-end Processor.

3-5-1-2 Turn on the system

Press the **Power On/Off** switch at the front of the system once.



Figure 3-4 Power On/Off Switch

When the **Power On/Off** switch on the Control Panel is pressed once, the Back-end Processor starts and the software code is distributed to initiate the scanner.

No status messages are displayed during this process.

3-5-2 Power Off/ Shutdown

NOTE: After turning off a system, wait at least ten seconds before turning it on again. The system may not be able to boot if power is recycled too quickly.

3-5-2-1 Back-end Processor Power Down

To power down the system:

- 1.) Press the **Power On/Off** switch once.

3-5-2-1 Back-end Processor Power Down (cont'd)

2.) The System-Exit window is displayed.

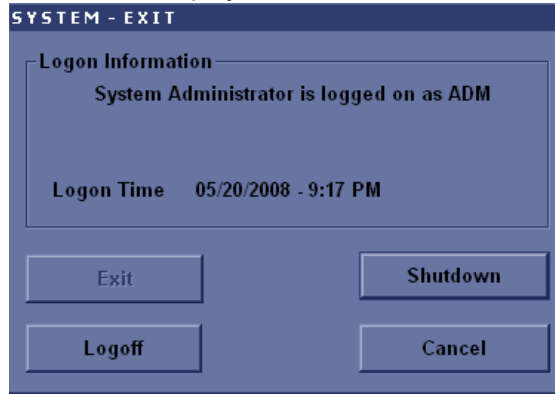

Figure 3-5 System Exit Window

- 3.) Using the Trackball or Select key, select Shutdown.
- 4.) The shutdown process takes a few seconds and is complete when the power status LED is turned amber.
- 5.) Disconnect the probes. Clean or disinfect all probes as necessary. Store them in their shipping cases to avoid damage.

3-5-2-2 Scanner Shutdown

Disconnect the Mains Power Cable if necessary. *For example:* Relocating the scanner.

3-5-3 Transducer Connection

1.) Plug the probe connector into the probe port, then lock the probe.

NOTE: Please ensure that the probe latch is in an unlocked position before you connect the probe to the system.

NOTE: It is not necessary to turn OFF power to connect or disconnect a probe.

Section 3-6 System Configuration

3-6-1 System Specifications

3-6-1-1 Physical Dimensions

The physical dimensions of the LOGIQ C Series unit are summarized in [Table 3-4 on page 3-10](#) .
The Size of LOGIQ C Series.

Table 3-4 Physical Dimensions of LOGIQ C Series

Height	Width	Depth	Unit
1400	500	700	mm
55.16	19.70	27.58	inches

3-6-1-2 Weight

Table 3-5 Weight of LOGIQ C Series With Monitor and Without Other Peripherals

Model	Weight [kg]	Weight [lb]
LOGIQ C Series	Approximately 75	Approximately 165

3-6-2 Electrical Specifications

Table 3-6 Electrical Specifications for LOGIQ C Series

System	Voltage	Current	Frequency
1	110 –120 V AC	500VA	50/60Hz
2	220– 240 V AC	500VA	50/60Hz

3-6-3 On-Board Optional Peripherals

Table 3-7 List of Optional Peripherals

Device	Manufacturer	Model	Video Signal
B/W Printer	SONY	UP-D897MD	USB
B/W Printer	SONY	UP-D257MD	USB
HP Printer	HP	HP 470b Officejet	USB
USB Memory	SanDisk	SanDisk 2G	USB
USB Memory	SanDisk	SanDisk 4G	USB
Footswitch	Whanam	FSU2001	USB
USB Hard Disk	Seagate	USBHDD 80G	USB
USB Hard Disk	Seagate	USBHDD 250G	USB
Color Printer	SONY	UP-D23MD	USB
ECG	NORAV	ECG -USB1	USB

NOTE: Color Printer and ECG are only supported by LOGIQ C5/C5 PRO.

NOTE: For detailed installation information and connection procedures, please refer to Peripheral Installation Instruction manual (5266280-100).

3-6-4 Connecting Cables

 **WARNING** Equipment damage possibility. Be sure to use the following recommended connecting cables to connect recording devices and a network with LOGIQ C Series console.

Table 3-8 List of Connecting Cables

Name	Part No.	Figure	NOTE
USB Cable	5122305		For USB Printer

3-6-5 Peripherals/Accessories Connector Panel

LOGIQ C Series peripherals and accessories can be properly connected using the side connector panel.

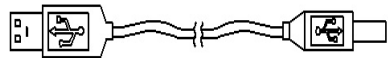
3-6-5-1 Rear Panel Connector

Located on the rear panel are Network port, 2 USB port, S-Video Out, VGA, Audio Out, Composite Out.



Figure 3-6 Rear Connector Panel

- 1.) Network Port
- 2.) 2 USB Ports (Printers, Footswitch, etc)
- 3.) S-Video Out
- 4.) VGA
- 5.) Audio Out
- 6.) Composite Out

NOTE: *Audio Out is not supported by LOGIQ C2/C2 PRO.*

3-6-5-2 Left Panel Connector

1 USB port is Located on the left panel.



Figure 3-7 Left Connector Panel

1.) 1 USB Ports (Printers, Footswitch, etc)

3-6-5-3 Printer Box Rear Panel connector

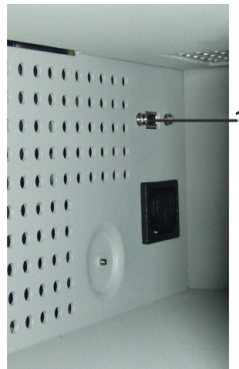

Figure 3-8 Printer Box Rear Connector Panel

1.) 1 USB Ports only for B/W Printer

NOTE: *Each outer (case) ground line of peripheral/accessory connectors are protectively grounded. Signal ground lines are not isolated, except the Service port (3). All of signal lines (include signal GND) of the Service port are isolated.*

3-6-5-4 Pin assignment for each connector

Table 3-9 Pin Assignments of External VGA

Pin No.	Signal	Pin No.	Signal
1	RED	9	NC
2	GREEN	10	NC
3	BLUE	11	NC
4	NC	12	NC
5	NC	13	HSY
6	GND	14	VSY
7	GND	15	NC
8	GND		

Table 3-10 Pin Assignments of USB

Pin No.	Signal	Pin No.	Signal
1	+5 VDC	5	+5 VDC
2	DATA	6	DATA
3	DATA	7	DATA
4	GND	8	GND

Table 3-11 Pin Assignments of Audio

Pin No.	Signal	Pin No.	Signal
1	GND	4	NC
2	L+	5	R+
3	Speaker L	6	Speaker R

Table 3-12 Pin Assignment of S-Video

Pin No.	Output Signal	Pin No.	Output Signal
1	GND	3	Y
2	GND	4	C

Table 3-13 Pin Assignment of Composite Video Out

Pin No.	Output Signal	Pin No.	Output Signal
1	Composite Out	2	GND

3-6-5-5 Connect Peripherals

- A.) Connect B/W printer to the system.
B/W Printer can be properly connected using USB Ports.



Figure 3-9 Connect B/W printer to the system

- B.) Connect UP-D23 color printer to the system. (Only supported by LOGIQ C5/C5 PRO)
UP-D23 Color Printer can be properly connected using USB Ports.



Figure 3-10 Connect color printer to the system

3-6-5-5 Connect Peripherals (cont'd)

C.) Connect Foot Switch to the system.

Foot Switch can be properly connected using USB Ports.



Figure 3-11 Connect Foot Switch to the system

D.) Connect the USB Memory to the system. The USB Memory can be properly connected using USB ports.



Figure 3-12 USB Memory Connection

E.) ECG can be properly connected using USB ports. (ECG only supported by LOGIQ C5/C5 PRO)



Figure 3-13 ECG

3-6-5-5 Connect Peripherals (cont'd)

F.) Connect the USB HDD to the system. The USB Harddisk can be properly connected using USB ports.



Figure 3-14 USB Hard Disk Connection

G.) Connect HP 470b Officejet printer to the system. HP 470b Officejet Printer can be properly connected using USB Ports



Figure 3-15 HP 470b Officejet printer Connection

3-6-6 Available Probes

See in specification in the LOGIQ C Series User Reference Manual for Probes and intended use.

Table 3-14 List of Probes on LOGIQ C Series

Probe Name	Material of Headshell	Area of Using	TYPE	Catalog Number
4C-RC	NORYL	GENERAL PURPOSE	CONVEX	H48102LE
3.8C-RC	NORYL	GENERAL PURPOSE	CONVEX	H48102LD
6.5C-RC	VALOX	VETERINARY PEDIATRIC NEONATAL	MICRO-CONVEX	H48102LF
E6C-RC	VALOX	TRANSVAGINAL TRANSRECTAL	MICRO-CONVEX	H48102LH
E7C-RC	VALOX	TRANSVAGINAL TRANSRECTAL	MICRO-CONVEX	H48102LG
7.5L-RC	VALOX	SMALL PARTS PERIPHERAL VASCULAR	LINEAR	H48102LJ
7L-RC	VALOX	SMALL PARTS PERIPHERAL VASCULAR	LINEAR	H48102LK
3S-RC	VALOX	CARDIAC	SECTOR	H40452LA

Section 3-7 Software/Option Configuration

Refer to the LOGIQ C Series Basic User Manual, Chapter 16, Customizing Your System for information on configuring items like Hospital, Department, Language, Units (of measure), Date, Time and Date Format.

For information on configuring Software Options, Refer to the LOGIQ C Series Basic User Manual, Chapter 16, Customizing Your System.

For information on configuring DICOM Connectivity, Refer to the LOGIQ C Series Basic User Manual, Chapter 16, Customizing Your System.

Section 3-8 Connectivity Installation Worksheet

Site System Information

Site: Floor: Comments:

Dept: Room:

LOGIQ SN: Type: REV:

CONTACT INFORMATION

Name	Title	Phone	E-Mail Address

TCP/IP Settings

Name - AE Title:

<p>IP Settings</p> <p>IP Address: <input type="text"/></p> <p>Subnet Mask: <input type="text"/></p> <p>Default Gateway: <input type="text"/></p>	<p>Remote Archive Setup</p> <p>Remote Archive IP: <input type="text"/></p> <p>Remote Archive Name: <input type="text"/></p>
---	--

Services (Destination Devices)

	Device Type	Manufacturer	Name	IP Address	Port	AE Title
1						
2						
3						
4						
5						
6						
7						
8						
9						
10						
11						
12						

Section 3-9 Loading Base Image Software

Refer to

[Section 8-3 "Loading Base Image Software" on page 8-3.](#)

Section 3-10 Software Version check out

3-10-1 Functional Check-out

- 1.) Power on LOGIQ C Series scanner and wait until system booting to main screen.
- 2.) Press UTILITY key on control panel.
- 3.) Choose the About button on the right.

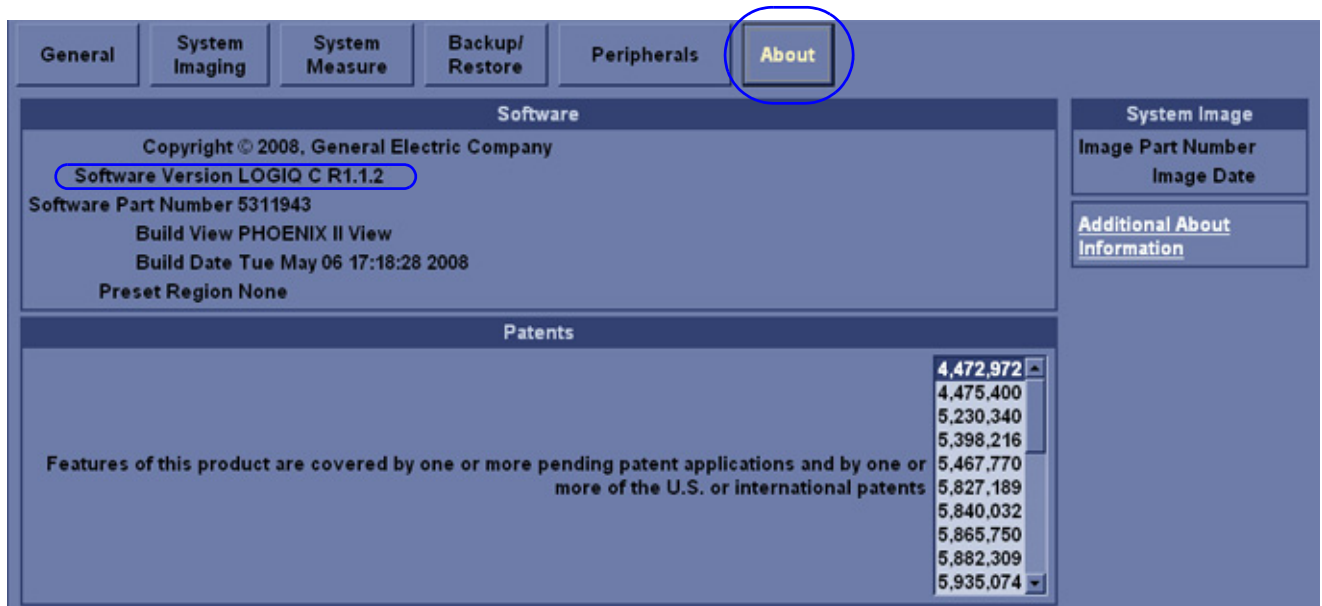

Figure 3-16 About and Software version

- 4.) Check whether "Software version" is the right version for use.

Section 3-11 Paperwork

NOTE: During and after installation, the documentation (i.e. User Manuals, Installation Manuals...) for the peripheral units must be kept as part of the original system documentation. This will ensure that all relevant safety and user information is available during the operation and service of the complete system.

3-11-1 Product Locator Installation

NOTE: The Product Locator Installation Card shown may not be same as the provided Product Locator card.

		GE Medical Systems Mailing Address Product Locator File P.O. Box 414 Milwaukee, WI 53201-0414		General Electric CGR Product Locator Adm. - DSE/SM 283 Route de la Miniere 78530 Buc, FRANCE		Yokogawa Medical Systems Ltd. GEMSA Service Administration 4-7-127 Asahigaoka Hino-shi Tokyo 191, JAPAN	
DESCRIPTION		FDA	MODEL		REV	SERIAL	
SYSTEM LTD.		DCC		BS	ORD	EMPLOYEE NO.	
		DISTRICT		ROOM		DATE (MO - DA - YR)	
INSTALLATION		CUSTOMER NO.					
		DESTINATION NAME AND ADDRESS					
46-303268 Rev 5		_____ _____ _____ _____					
		ZIP CODE					

Figure 3-17 Product Locator Installation Card

3-11-2 User Manual(s)

User Check that the correct User Manual(s) for the system and software revision, is included with the installation. Specific language versions of the User Manual may also be available. Check with your GE Sales Representative for availability.

Chapter 4

Functional Checks

Section 4-1 Overview

4-1-1 Purpose for Chapter 4

This chapter provides procedures for quickly checking major functions of the LOGIQ C Series console, diagnostics by using the built-in service software, and power supply.

Table 4-1 Contents in Chapter 4

Section	Description	Page Number
4-1	"Overview"	4-1
4-2	"Required Equipment"	4-1
4-3	"General Procedure"	4-2
4-4	"Software Configuration Checks"	4-35
4-5	"Peripheral Checks"	4-35

Section 4-2 Required Equipment

To perform these tests, you'll need any of the sector, linear, or convex transducers.
(normally you should check all the transducers used on the system)

Section 4-3 General Procedure



CAUTION SYSTEM REQUIRES ALL COVERS

Operate this unit only when all board covers and frame panels are securely in place. The covers are required for safe operation, good system performance and cooling purposes.

4-3-1 Power On/Boot Up

After connect the system to the electrical supply, the power is applied to the scanner. When the Control panel **Power On/Off** key is pressed once, the System starts.

4-3-1-1 Scanner Power On

When power is applied to the scanner, power is distributed to the Cooling Unit, Control Panel, LCD, Peripherals and the Back-end Processor.

4-3-1-2 Turn on the system

Press the **Power On/Off** switch at the front of the system once.



Figure 4-1 Power On/Off Switch

When the **Power On/Off** switch on the Control Panel is pressed once, the Back-end Processor starts and the software code is distributed to initiate the scanner.

No status messages are displayed during this process.

4-3-2 Power Off/ Shutdown

NOTE: After turning off a system, wait at least ten seconds before turning it on again. The system may not be able to boot if power is recycled too quickly.

4-3-2-1 Back-end Processor Power Down

To power down the system:

- 1.) Press the **Power On/Off** switch at the front of the system once.

4-3-2-1 Back-end Processor Power Down (cont'd)

- 2.) The System-Exit window is displayed.

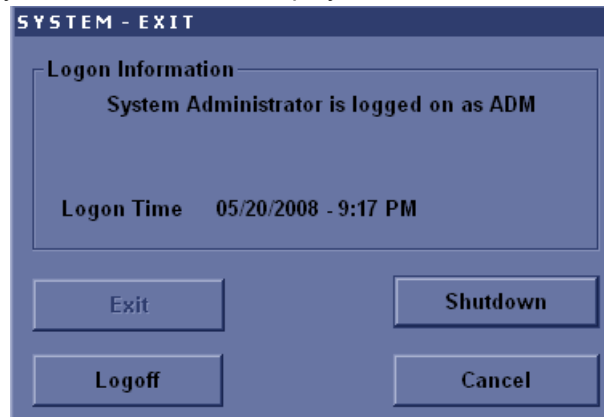

Figure 4-2 System Exit Window

- 3.) Using the Trackball or Select key, select Shutdown.
4.) The shutdown process takes a few seconds and the power off sequence is complete when the power status LED is turned amber.
5.) Disconnect the probes. Clean or disinfect all probes as necessary. Store them in their shipping cases to avoid damage.

4-3-2-2 Scanner Shutdown

Disconnect the Mains Power Cable is necessary. *For example:* Relocating the scanner.



CAUTION DO NOT unplug and/or transport the unit until after the power off sequence has been completed. Failure to do so may result in corrupted patient files.

4-3-3 Archiving and Loading Presets

NOTE: Always save presets before any software reload. This ensures the presets loaded after the software reload are as up-to-date as possible.

NOTE: The system may crash if use a DVD for Archive/Backup/EZBackup/Restore, so always use a CD-R or USB HDD for Archive/Backup/EZBackup/Restore. DVD only can be used for upgrade.

All user presets except changes to Summary, Anatomy, and Biometry pages, can be saved on an CD-R disk (or USB memory device) for reloading on the system.

NOTICE Presets should NOT be saved on the same CD-R disk (or USB memory device) as images. The Archive Menu lists the images but does NOT list the presets stored on a CD-R disk (or USB memory device).

4-3-3-1 Archiving Presets to an CD-R Disk (or USB memory device)

- 1.) Insert an empty (blank) CD-R disk into the DVD-RW.
- 2.) Access to the Utility Menu, and select System. The Backup sheet will be shown on the LCD display.

The screenshot displays the 'Backup/Restore' utility menu for a GE 6.5C-RC Neo Abd system. The menu is organized into several sections:

- Backup Section:** Contains checkboxes for 'Patient Archive', 'Report Archive', 'User Defined Configuration', and 'Service', each with a 'No Record' status. A 'Backup' button is located at the bottom of this section.
- Restore Section:** Contains checkboxes for 'Patient Archive', 'Report Archive', 'User Defined Configuration', and 'Service', each with a 'No Record' status. A 'Restore' button is located at the bottom of this section.
- Media Section:** A dropdown menu for 'Media' is set to 'CD / DVD'.
- EZMove Section:** Includes a 'Move Files Older Than in Days' dropdown set to '7', a 'Media' dropdown set to 'CD / DVD', and a 'Media capacity for estimate (MB)' dropdown set to '700'.
- EZBackup Section:** Includes a 'Reminder Dialog Interval Days(EzBackup)' dropdown set to '1', an 'Enable Reminder Dialog(EzBackup)' checkbox, a 'Backup Files Older Than in Days' dropdown set to '7', a 'Media' dropdown set to 'CD / DVD', and a 'Media capacity for estimate (MB)' dropdown set to '700'.
- Emergency Repair Disk Section:** Includes a 'Reminder Dialog Interval Days' dropdown set to '60' and an 'Enable Reminder Dialog' checkbox.
- Detailed Restore of User Defined Section:** Contains checkboxes for 'Imaging Presets', 'Connectivity Configuration', 'Measurement Configuration', 'Comment/Body Pattern Libraries', and 'All Others'. A 'Restore' button is located at the bottom of this section.

Figure 4-3 Backup Sheet

- 3.) Select the item to back up either from Resource Files.
- 4.) Enter backup destination or browse through the disk to locate the destination.
- 5.) Select Backup now. The backup status for each item is displayed on the Result column.

4-3-3-2 Loading Presets from an CD-R disk (or USB memory device)

- 1.) Insert the CD-R disk with the archived Presets into the DVD-RW.
- 2.) Access to the Utility Menu, and select System. The Restore sheet will be shown on the LCD display.
- 3.) Select the item to restore either from Resource Files.
- 4.) Enter restore destination or browse through the disk to locate the destination.
- 5.) Select Restore. The restore status for each item is displayed on the Result column.

4-3-4 Adjusting the Display Monitor

Please refer to [Section 6-2 "Monitor Adjustments" on page 6-2](#)

4-3-5 System Features

4-3-5-1 Control Panel



Figure 4-4 Control Panel Tour

- 1.) Power On/Off Switch
- 2.) Probe Key
- 3.) Top Menu Controls
- 4.) Keyboard
- 5.) Preset, Comment, Harmonics keys
- 6.) Patient key
- 7.) Mode keys: B-Mode, M-Mode, PW-Mode, CF Mode.
- 8.) Gain/Auto key
- 9.) Zoom key
- 10.) Ellipse key
- 11.) Depth key
- 12.) Reverse, Print, Store keys
- 13.) Left, Right key
- 14.) Freeze key
- 15.) Trackball
- 16.) Imaging/Masurement keys
- 17.) TGC
- 18.) Gel Holder
- 19.) Probe Holder

NOTE: LOGIQ C2/C2 PRO do not have Harmonics keys and press CTRL+H to active Harmonics mode

NOTE: LOGIQ C2/C2 PRO do not support PW Mode and CF Mode, and do not have PW and CF mode key, LOGIQ C3/C3 PRO do not support CF Mode, and do not have CF mode key.

4-3-5-2 LOGIQ C Series SoftMenu Key Tour

1.) Top Menu Controls op Menu Controls



Figure 4-5 SoftMenu Key Tour

2.) Sub menu Controls: Activates Sub Menu for Modes and toggles/changes functions

A.) Press F5 on the keyboard to activate Sub Menu,

B.) Use the Direction keys to toggle/change functions

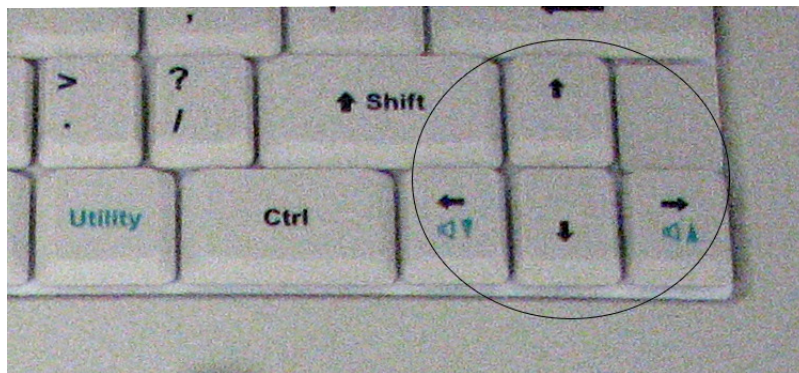

Figure 4-6 Sub Menu Controls

4-3-5-3 Monitor Display

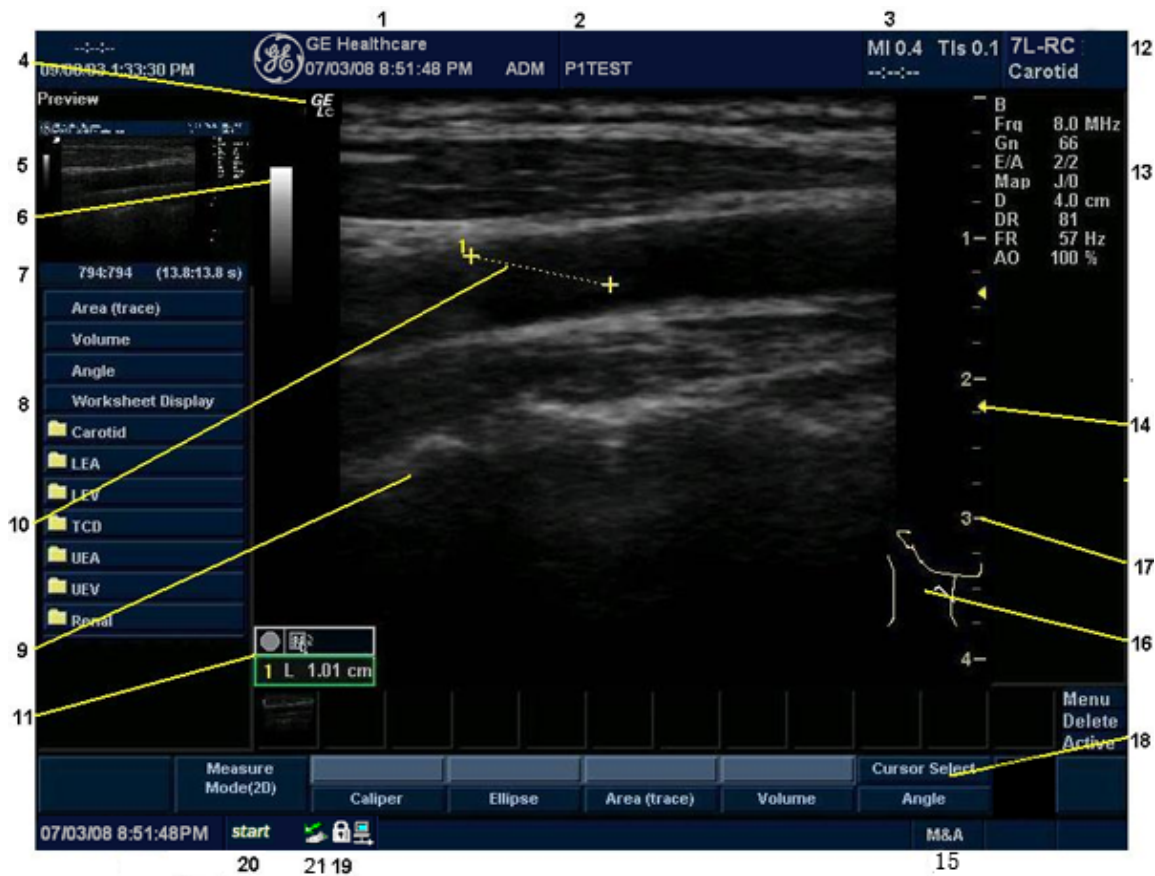

Figure 4-7 Monitor Display Tour

Table 4-2 Monitor Display Features

1. Institution/Hospital Name, Date, Time, Operator Identification, system status (real-time or frozen).	12. Probe Identifier. Exam Study.
2. Patient Name, Patient Identification.	13. Imaging Parameters by Mode (current mode highlighted).
3. Acoustic Output Readout,	14. Focal Zone.
4. GE Symbol: Probe Orientation Marker. Coincides with a probe orientation marking on the probe.	15. Trackball Functionality Status: Scroll, M&A (Measurement and Analysis), Position, Size, Scan Area Width and Tilt.
5. Image Preview.	16. Body Pattern.
6. Grey/Color Bar.	17. Depth Scale.
7. Cine Gauge.	18. SoftMenu
8. Measurement Summary Window.	19. Caps Lock: On/Off.
9. Image.	20. Start menu icon.
10. Measurement.	21. Card icon.
11. Results Window.	

4-3-6 B Mode Checks

4-3-6-1 Preparations

- 1.) Connect one of the probes listed in 3-6-6 "Available Probes" on page 3-18, in Chapter 3 Installation to the System probe connector.
- 2.) Turn ON the scanner (if it isn't turned on already).



Figure 4-8 Controls available in B Mode



Figure 4-9 B Mode Screen Picture Example

4-3-6-2 B Mode OP Panel Controls

Table 4-3 B Mode Control Panel Controls

Step	Task	Expected Result(s)
1	Press B Mode key	B Mode Starts
2	Adjust Depth	Adjust the field of view. Increasing the depth may view larger/deeper structures rates, and decreasing the depth may view near the skin line. Press Up/Down Button to increase/decrease. Depth displays on the monitor in cm.
3	Adjust Gain	Controls the amount of echo information displayed in an image. Turn B Mode dial to the left/right to increase/decrease Gain. Gain displays on the monitor in G (dB).
4	Adjust Focus	Increases the number of focal zones or moves the focal zone(s) to tighten up the beam for specific area. Press the control to toggle between Focus Position and Focus Number. Press Up/Down Button to move or adjust the focal numbers.
5	Activate Auto Optimize	Optimize the image based upon a specified region of interest or anatomy. Press the Center Button in the Gain Dial to toggle the ATO/ACE On and Off.
7	Adjust Time Gain Compensation (TGC)	Amplifies the returning signals to correct for the attenuation caused by tissues at increasing depth. TGC slide pots spaced proportional to the depth. Move the slide pots to the left/right to decrease/increase TGC. A TGC curve appears on the display.
8	Adjust Scan Area	Widen or narrow the size of the sector angle to maximize the image's region of interest (ROI). Press Scan Area and move the Trackball to narrow/widen the angle.
9	Adjust Zoom	Changes the location of the focal point(s). A triangular focus marker indicates the depth of the focal point.
10	Zoom Clear	Clear Zoom to normal condition.
11	Reverse	Toggles the left/right orientation of the scan image.

4-3-6-3 B Mode Softmenu

Table 4-4 B Mode Softmenu

Step	Task	Expected Result(s)
1	Activate Colorize	Enables gray scale image colorization. To deactivate, reselect a Gray Map.
2	Adjust Edge Enhance	Edge Enhance brings out subtle tissue differences and boundaries by enhancing the gray scale differences corresponding to the edges of structures. Adjustments to M Mode's edge enhancement affects the M Mode only.
3	Activate Grey Map	Determines how the echo intensity levels received are presented as shades of gray.
4	Adjust Frequency	Multi Frequency mode lets you downshift to the probe's next lower frequency or shift up to a higher frequency.
5	Adjust Frame Average	Temporal filter that averages frames together. This has the effect of presenting a smoother, softer image.
6	Adjust Rotation	Rotates the image by selecting the value from the pop-up menu.
7	Power output	Optimizes image quality and allows user to reduce beam intensity. 10% increments between 0-100%. Values greater than 0.1 are displayed.
8	Dynamic Range	Dynamic Range controls how echo intensities are converted to shades of gray, thereby increasing the adjustable range of contrast.
9	Focus Number and Position	Increases the number of transmit focal zones or moves the focal zone(s) so that you can tighten up the beam for a specific area. A graphic caret corresponding to the focal zone position(s) appears on the right edge of the image.
10	Adjust Rejection	Selects a level below which echoes will not be amplified (an echo must have a certain minimum amplitude before it will be processed).

4-3-7 M Mode Controls

4-3-7-1 Preparations

- 1.) Connect one of the probes listed in 3-6-6 "Available Probes" on page 3-18, in Chapter 3 Installation to the System probe connector.
- 2.) Turn ON the scanner (if it isn't turned on already).



Figure 4-10 Controls available in M Mode

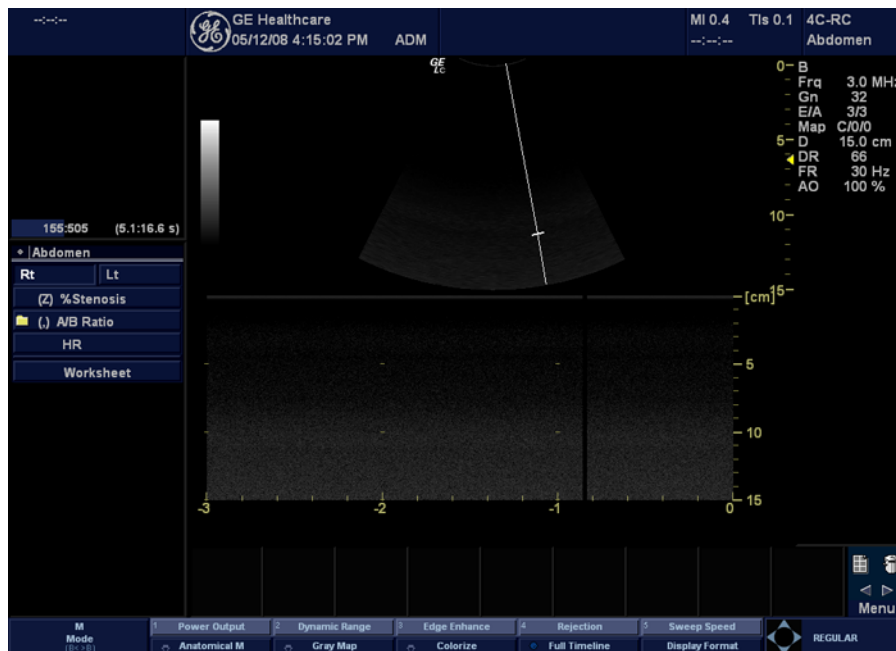

Figure 4-11 M Mode Screen Picture Example

4-3-7-2 M Mode OP Panel Controls

Table 4-5 M Mode OP Panel Controls

Step	Task	Expected Result(s)
1	Press M Mode key	M Mode Starts
2	Adjust Gain	Controls the amount of echo information displayed in an image. Turn B Mode dial to the left/right to increase/decrease Gain. Gain displays on the monitor in G (dB).
3	Display M-Mode Cursor	Displays the M-Mode cursor on the B-Mode image. Press Cursor and Trackball to position M-Mode Cursor.

4-3-7-3 M Mode Softmenu

Table 4-6 M Mode Softmenu

Step	Task	Expected Result(s)
1	Adjust Sweep Speed	Changes the speed at which the time line is swept. The following speed values are available, 1, 2, 3, 4, 6, 8, 12, 16.
2	Adjust Edge Enhance	Edge Enhance brings out subtle tissue differences and boundaries by enhancing the gray scale differences corresponding to the edges of structures. Adjustments to M Mode's edge enhancement affects the M Mode only.
3	Activate Grey Map	Determines how the echo intensity levels received are presented as shades of gray.
4	Activate Colorize	Enables gray scale image colorization. To deactivate, reselect a Gray Map.
5	Activate Full Timeline	Displays only timeline screen. Press the Full Timescreen to activate.
6	Select Display Format	Select the format to display B image and M image on the LCD. Press Display Format, and select from the pop up menu.
7	Adjust Dynamic Range	Dynamic Range controls how echo intensities are converted to shades of gray, thereby increasing the adjustable range of contrast.
8	Power output	Optimizes image quality and allows user to reduce beam intensity. 10% increments between 0-100%. Values greater than 0.1 are displayed.
9	Anatomical M	Enter into AMM Mode (Option).
10	Adjust Rejection	Selects a level below which echoes will not be amplified (an echo must have a certain minimum amplitude before it will be processed).

4-3-8 Doppler Mode Checks

NOTE: Doppler Mode is not supported by LOGIQ C2/C2 PRO.

4-3-8-1 Preparations

- 1.) Connect one of the probes listed in 3-6-6 "Available Probes" on page 3-18, in Chapter 3 Installation to the System probe connector.
- 2.) Turn ON the scanner (if it isn't turned on already).



Figure 4-12 Controls available in Doppler Mode

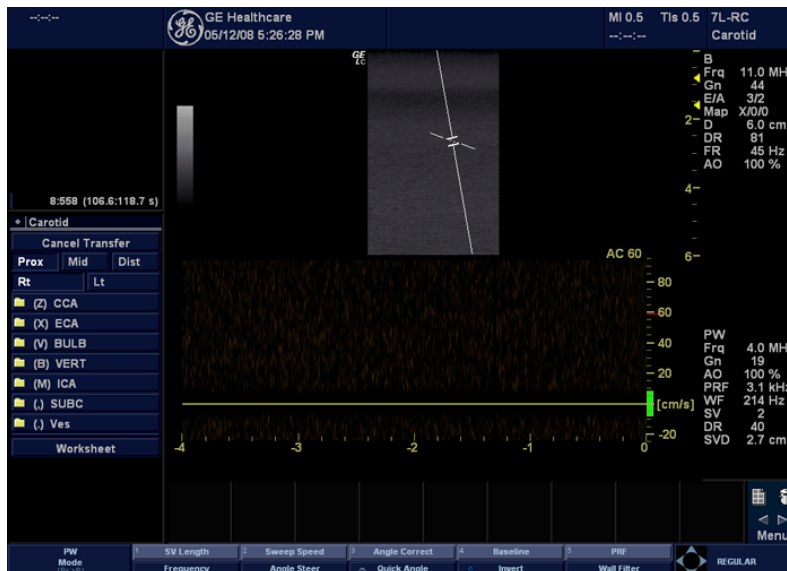

Figure 4-13 Doppler Mode Screen Picture Example

4-3-8-2 Doppler Mode OP Panel Controls

Table 4-7 Doppler Mode OP Panel Controls

Step	Task	Expected Result(s)
1	Press PW Mode key	PW Mode Starts
2	Adjust Gain	Amplifies the overall strength of the echoes processed in the Color Flow window. Turn the Gain dial (PW Mode key) to the left/right to increase/decrease Gain.
3	Display M/D-Mode Cursor	Displays the M/D-Mode cursor on the B-Mode image. Press Cursor and Trackball to position sample volume graphic. Click SV gate to adjust sample volume gate size.
4	B-Pause	Toggle between simultaneous and update presentation while viewing Spectral Doppler. Press B Pause to toggle between simultaneous and update.

4-3-8-3 Doppler Mode OP Panel Controls

Table 4-8 Doppler Mode Touch Panel Controls

Step	Task	Expected Result(s)
1	Adjust Rejection	Selects a level below which echoes will not be amplified (an echo must have a certain minimum amplitude before it will be processed).
2	Adjust Sweep Speed	Changes the speed at which timeline is swept. Press Sweep Speed up/down to increase/decrease the value.
3	Activate Full Timeline	Displays only timeline screen. Press the Full Timescreen to activate.
4	Select Display Format	Display layout can be preset to have B-Mode and Time-motion side-by-side or over-under.
5	Adjust Frequency	Enables the adjustment of the probe's operating frequency. Press Frequency and select desired value. The selected frequency is displayed in the status window.
6	Trace Direction	Allows to select different trace direction.
7	Invert	Vertically inverts the spectral trace without affecting the baseline position. Press invert to invert the spectral trace. The Plus and Minus signs on the velocity scale reverse when the spectrum is inverted.
8	Auto Calculation	Enables or disables auto calculation.
9	Modify Calcs	Activates the window to modify the auto calculation items.
10	Trace Method	Allows to select different trace method.
11	Activate Colorize	Colorize the gray scale image to enhance the eyes' discrimination capability. Press the Colorize, Trackball to cycle through available maps and press Set to select.
12	Activate Gray Map	Displays a map window adjacent to the image. Move the trackball to select the map. The image reflects the map as scrolled through the selections. Press Set to select.
13	Dynamic Range	Controls how echo intensities are converted to shades of gray. Click Dynamic Range to increase/decrease the value.
14	Adjust Angle Correct	Estimates the flow velocity in a direction at an angle to the Doppler vector by computing the angle between the Doppler vector and the flow to be measured.
15	Adjust Angle Steer	Slant the Color Flow linear image left or right to get more information without moving probes. Click Angle Steer to the left to slant the linear image.
16	Move Baseline	Adjusts the baseline to accommodate faster or slower blood flows to eliminate aliasing.

Table 4-8 Doppler Mode Touch Panel Controls

Step	Task	Expected Result(s)
17	Change PRF (Pulse Repetition Frequencies) - (Wall Filter)	Velocity scale determines pulse repetition frequency. If the sample volume gate range exceeds single gate PRF capability, the system automatically switches to high PRF mode. Multiple gates appear, and HPRF is indicated on the display.
18	Trace Sensitivity	Adjusts the sensitivity to get more accurate envelope trace.
19	Time Resolution	Adjusts the resolution in frequency domain.
20	Spectral Average	Optimizes the smoothness of the spectrum. Different levels can be selected.
21	Power output	Optimizes image quality and allows user to reduce beam intensity. 10% increments between 0-100%. Values greater than 0.1 are displayed.
22	SV Length	Sizes the sample volume gate.
23	Wall Filter	Wall Filter insulates the Doppler signal from excessive noise caused from vessel movement.

4-3-9 Color Flow Mode Checks

NOTE: Color Flow Mode only support by LOGIQ C5/C5 PRO

4-3-9-1 Preparations

- 1.) Connect one of the probes listed in 3-6-6 "Available Probes" on page 3-18, in Chapter 3 Installation to the System probe connector.
- 2.) Turn ON the scanner (if it isn't turned on already).



Figure 4-14 Controls available in Color Flow Mode

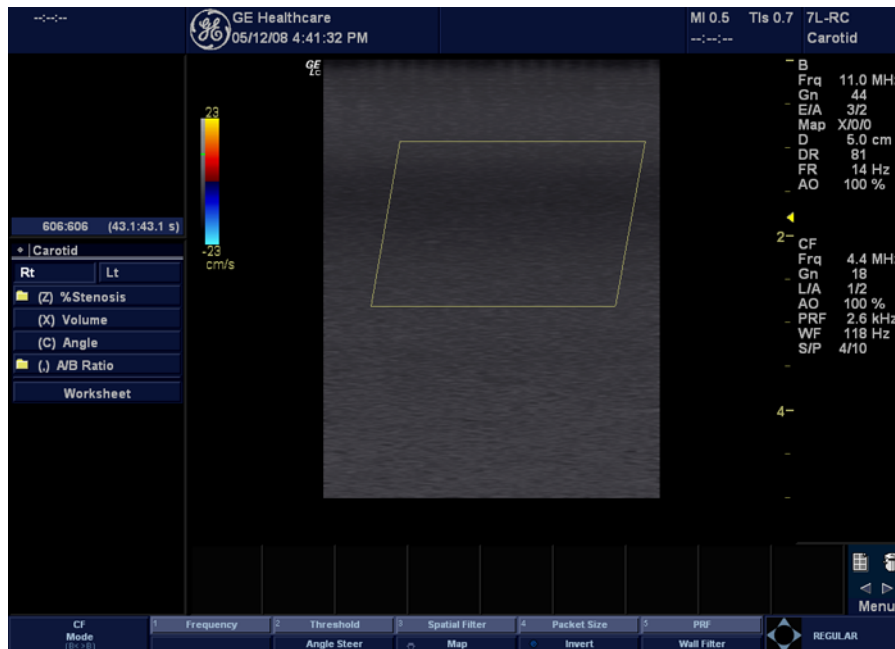

Figure 4-15 CFM Mode Screen Picture Example

4-3-9-2 Color Flow Mode OP Panel Controls

Table 4-9 Color Flow Mode OP Panel Controls

Step	Task	Expected Result(s)
1	Press CFM-Mode key	CFM Mode Starts
2	Adjust Gain	Amplifies the overall strength of the echoes processed in the Color Flow window. Turn the Gain dial (CFM Mode key) to the left/right to increase/decrease Gain.

4-3-9-3 Color Flow Mode Softmenu Key

Table 4-10 Color Flow Mode Softmenu Key

Step	Task	Expected Result(s)
1	Threshold	Threshold assigns the gray scale level at which color information stops.
2	Packet Size	Controls the number of samples gathered for a single color flow vector.
3	Select Color maps	Allows a specific color map to be selected. After a selection has been made, the color bar displays the resultant map.
4	Adjust Frequency	Enables the adjustment of the probe's operating frequency. Press Frequency and select desired value. The selected frequency is displayed in the status window.
5	Set Frame Average	Averages color frames. Press Frame Average up/down to smooth temporal averaging.
6	Color Invert	Views blood flow from a different perspective. Press Invert to reverse the color map.
7	Adjust Line Density	Trades frame rate for sensitivity and spatial resolution. If the frame rate is too slow, reduce the size of the region of interest, select a different line density setting, or reduce the packet size.
8	Activate Spatial Filter	
9	Adjust Dynamic Range	Dynamic Range controls how echo intensities are converted to shades of gray, thereby increasing the adjustable range of contrast.
10	Activate ACE	Eliminates the motion artifacts. Press Ace to activate.
11	Adjust Angle Steer	Slants the Color Flow region of interest or the Doppler line to obtain a better Doppler angle.
12	Move Baseline	Adjusts the baseline to accommodate faster or slower blood flows to eliminate aliasing.
13	Change PRF (Pulse Repetition Frequency)	Velocity scale determines pulse repetition frequency. If the sample volume gate range exceeds single gate PRF capability, the system automatically switches to high PRF mode. Multiple gates appear, and HPRF is indicated on the display.
14	Transparency Map	Allows to select specific transparency map
15	Focus Position	Increases the number of transmit focal zones or moves the focal zone(s) so that you can tighten up the beam for a specific area. A graphic caret corresponding to the focal zone position(s) appears on the right edge of the image.
16	Capture	

Table 4-10 Color Flow Mode Softmenu Key

Step	Task	Expected Result(s)
17	Power output	Optimizes image quality and allows user to reduce beam intensity. 10% increments between 0-100%. Values greater than 0.1 are displayed.
18	Wall Filter	Wall Filter insulates the Doppler signal from excessive noise caused from vessel movement.

4-3-10 Basic Measurements

*NOTE: The following instructions assume that you first scan the patient and then press **Freeze**.*

4-3-10-1 Distance and Tissue Depth Measurements

- 1.) Press **MEASURE** once; an active caliper displays.
- 2.) To position the active caliper at the start point (distance) or the most anterior point (tissue depth), move the **TRACKBALL**.
- 3.) To fix the start point, press **Set**. The system fixes the first caliper and displays a second active caliper.
- 4.) To position the second active caliper at the end point (distance) or the most posterior point (tissue depth), move the **TRACKBALL**.
- 5.) To complete the measurement, press **SET**. The system displays the distance or tissue depth value in the measurement results window.

Before you complete a measurement:

To toggle between active calipers, press **MEASURE**.

To erase the second caliper and the current data measured and start the measurement again, press **CLEAR** once.

*NOTE: To rotate through and activate previously fixed calipers, adjust **CURSOR SELECT**.*

*NOTE: After you complete the measurement, to erase all data that has been measured to this point, but not data entered onto worksheets, press **CLEAR**.*

4-3-10-2 Circumference/Area (Ellipse) Measurement

- 1.) Press **MEASURE** once; an active caliper displays.
- 2.) To position the active caliper, move the **TRACKBALL**.
- 3.) To fix the start point, press **SET**. The system fixes the first caliper and displays a second active caliper.
- 4.) To position the second caliper, move the **TRACKBALL**.
- 5.) Adjust the **ELLIPSE**; an ellipse with an initial circle shape appears.

NOTE: Be careful not to press the Ellipse control as this activates the Body Pattern.

- 6.) To position the ellipse and to size the measured axes (move the calipers), move the **TRACKBALL**.
- 7.) To increase the size, adjust the **ELLIPSE** upward button. To decrease the size, adjust the **ELLIPSE** downward button.
- 8.) To toggle between active calipers, press **MEASURE**.
- 9.) To complete the measurement, press **SET**. The system displays the circumference and area in the measurement results window.

Before you complete a measurement:

- To erase the ellipse and the current data measured, press **CLEAR** once. The original caliper is displayed to restart the measurement.
- To exit the measurement function without completing the measurement, press **CLEAR** a second time.

4-3-10-3 Worksheets

Measurement/Calculation worksheets are available to display and edit measurements and calculations. There are generic worksheets as well as Application specific worksheets. The worksheets are selected from the Measurement Touch Panel.

4-3-10-4 Report Pages

Measurements/Calculations that are included on the worksheet can also be displayed on Report Pages. Report Pages can be customized to meet the appropriate needs of the user.

4-3-11 Probe/Connectors Usage

4-3-11-1 Connecting a probe

- 1.) Place the probe's carrying case on a stable surface and open the case.
- 2.) Carefully remove the probe and unwrap the probe cable.
- 3.) DO NOT allow the probe head to hang free. Impact to the probe head could result in irreparable damage.
- 4.) Align the connector with the probe port and carefully push into place.
- 5.) Lock the probe.
- 6.) Carefully position the probe cord so it is free to move and is not resting on the floor.

4-3-11-2 Activating the probe

The probe activates in the currently-selected operating mode. The probe's default settings for the mode and selected exam are used automatically.

4-3-11-3 Deactivating the probe

- 1.) Press the **Freeze** key.
- 2.) Gently wipe the excess gel from the face of the probe. (Refer to the Basic User Manual for complete probe cleaning instructions.)
- 3.) Carefully slide the probe around the right side of the keyboard, toward the probe holder. Ensure that the probe is placed gently in the probe holder.

4-3-11-4 Disconnecting the probe

Probes can be disconnected at any time. However, the probe should not be selected as the active probe.

- 1.) Unlock the probe.
- 2.) Pull the probe and connector straight out of the probe port.
- 3.) Carefully slide the probe and connector away from the probe port and around the right side of the keyboard.
- 4.) Ensure the cable is free.
- 5.) Be sure that the probe head is clean before placing the probe in its storage box.

 **WARNING** *Take the following precautions with the probe cables: Do not bend, be sure to keep probe cables free from the wheels.*

4-3-12 Using Cine

4-3-12-1 Activating CINE

Press **Freeze**, then roll the **Trackball** to activate CINE. To start CINE Loop playback, press Run/Stop. To stop CINE Loop playback, press Run/Stop.

4-3-12-2 Quickly Move to Start/End Frame

Press **First** to move to the first CINE frame; press **Last** to move to the last CINE frame.

4-3-12-3 Start Frame/End Frame

Press the **Start Frame** Two-Button Softkey to move to the beginning of the CINE Loop. Adjust the **Start Frame** up/down Two-Button Softkey upward to move forward through the CINE Loop. Adjust the Softkey downward to move backward through the CINE Loop.

Press the **End Frame** Two-Button Softkey to move to the end of the CINE Loop. Adjust the **End Frame** up/down Two-Button Softkey upward to move forward through the CINE Loop. Adjust the Softkey downward to move backward through the CINE Loop.

4-3-12-4 Adjusting the CINE Loop Playback Speed

Adjust the **Loop Speed** up/down Two-Button Softkey to increase/decrease the CINE Loop playback speed.

4-3-12-5 Moving through a CINE Loop Frame By Frame

Adjust the **Frame by Frame** up/down Two-Button Softkey to move through CINE memory one frame at a time.

4-3-13 Image Management (QG)

For Image Management functionality refer to the LOGIQ C Series Quick Guide. It talks about several topics:

- Clipboard*
- Printing Images
- Browsing and Managing an Exam's Stored Image
- Connectivity, and Dataflow Concept and Creation
- Starting an Exam
- Configuring Connectivity
- TCP/IP
- Services (Destinations)
- Buttons
- Views
- Verifying and Pinging a Device



NOTICE Clipboard* function is not available on LOGIQ C2 PRO.

4-3-14 Backup and Restore Database, Preset Configurations and Images

4-3-14-1 Formatting Media

NOTE: *The system may crash if use a DVD for Archive/Backup/EZBackup/Restore, so always use a CD-R or USB HDD for Archive/Backup/EZBackup/Restore. DVD only can be used for upgrade.*

- 1.) To format the backup media, select the **UTILITY** button on the Keyboard.
- 2.) Select **CONNECTIVITY**, then **REMOVABLE MEDIA**. Properly label and Insert the backup media.
- 3.) Select the media type from the drop down menu.
- 4.) Enter the label for the media as shown in Figure 4-16. It is best to use all capital letters with no spaces or punctuation marks. Press **Format**.

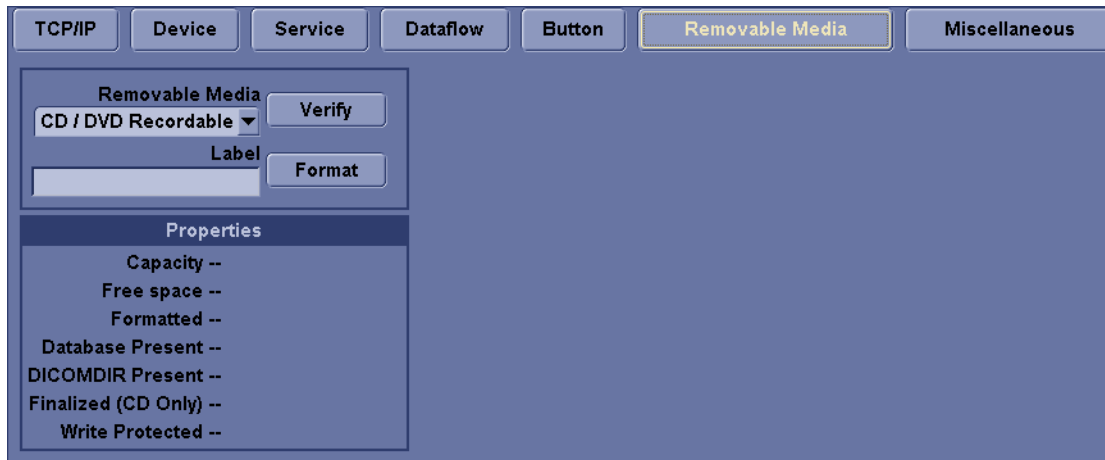

Figure 4-16 Format and Verify Media

- 5.) The Ultrasound system displays a pop-up menu, as shown in Figure 4-17. When the formatting has been completed, press **OK** to continue.
- 6.) If desired, verify that the format was successful by returning to **Utility->Connectivity->Removable Media** and selecting **VERIFY** as shown in Figure 4-16.

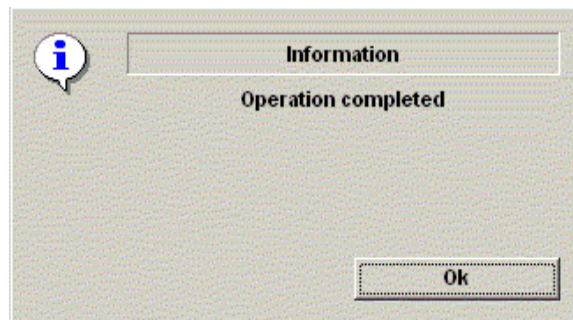

Figure 4-17 Format Successful Pop-up Menu

4-3-14-2 Backup System Presets and Configurations

NOTE: Always backup any preset configurations before a software reload. This ensures that if the presets need to be reloaded, after the software update, they will be the same ones the customer was using prior to service.

- 1.) Insert a formatted CD into the drive.
- 2.) On the Keyboard, press UTILITY.
- 3.) On the LCD display, press SYSTEM.
- 4.) On the LCD display, select BACKUP/RESTORE.

NOTE: If you are not logged in as GE Service or with administrator privileges, the Operator Login window is displayed. Log on with administrator privileges.

- 5.) In the Backup list, select Patient Archive, Report Archive and User Defined Configuration.
- 6.) In the Media field, select CD/DVD (or USB memory device).
- 7.) Select BACKUP.

The system performs the backup. As it proceeds, status information is displayed on the Backup/Restore screen.

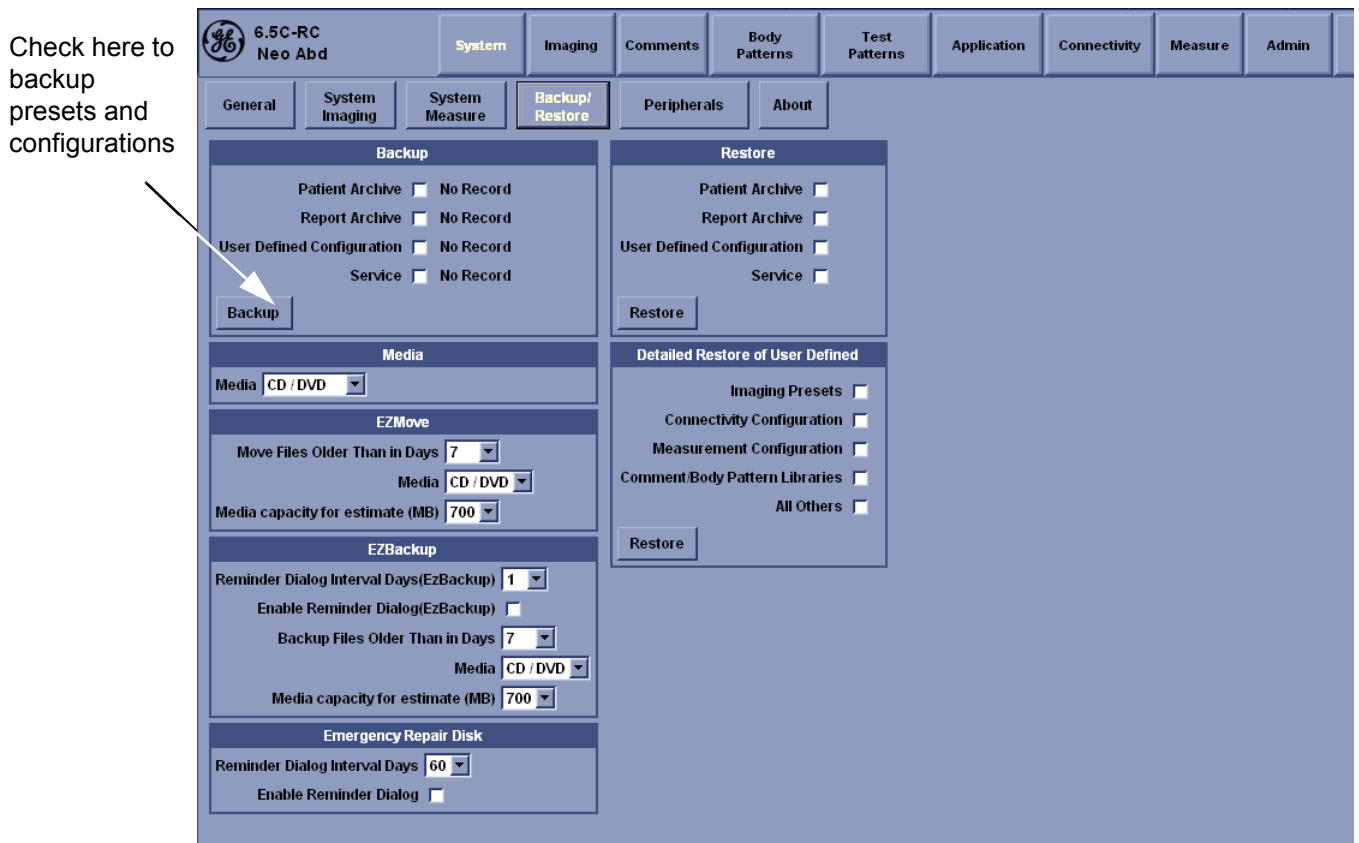



Figure 4-18 Backup/Restore Menu

4-3-14-3 Restore System Presets and Configurations

 **CAUTION** The restore procedure **overwrites** the existing database on the local hard drive. Make sure to insert the correct CD (or USB memory device).

- 1.) Insert the Backup/Restore CD (or USB memory device) into the drive.
- 2.) On the Keyboard, press **UTILITY**.
- 3.) On the LCD display, press **SYSTEM**.
- 4.) On the LCD display, select **BACKUP/RESTORE**.

NOTE: *If you are not logged in with administrator privileges, the Operator Login window is displayed. Log on with administrator privileges.*

- 5.) In the Restore list, select Patient Archive, Report Archive and User Defined Configuration.
- 6.) In the Media field, select the Backup/Restore CD/DVD (or USB memory device).
- 7.) Select **RESTORE**.

The system performs the restore. As it proceeds, status information is displayed on the Backup/Restore screen.

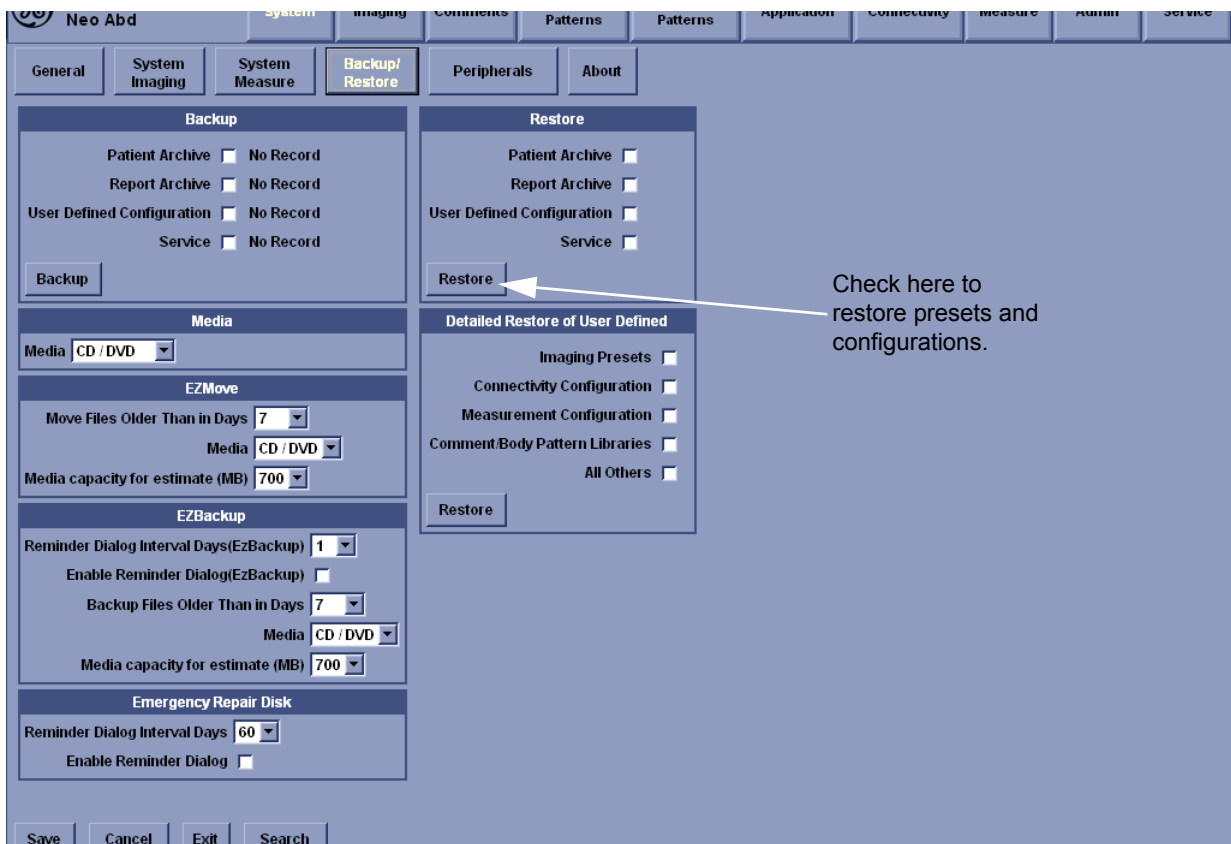

Figure 4-19 Backup/Restore Menu

4-3-14-4 Archiving Images

- 1.) Insert the archive media. To format the archive media, select the Utility button on the Keyboard.
- 2.) Select Connectivity, then Removable Media.
- 3.) Format the CD. Verify the format if desired.
- 4.) Images will be moved from the hard drive by date. Therefore, the best way is to label media by date.

NOTE: Images will be moved from the hard drive by date. Therefore, the best way to label media is by date. When images are moved to the archive media, they will be deleted from the system hard drive. However, the patient database (backed up earlier) maintains pointers to the location of the images on the archive media.

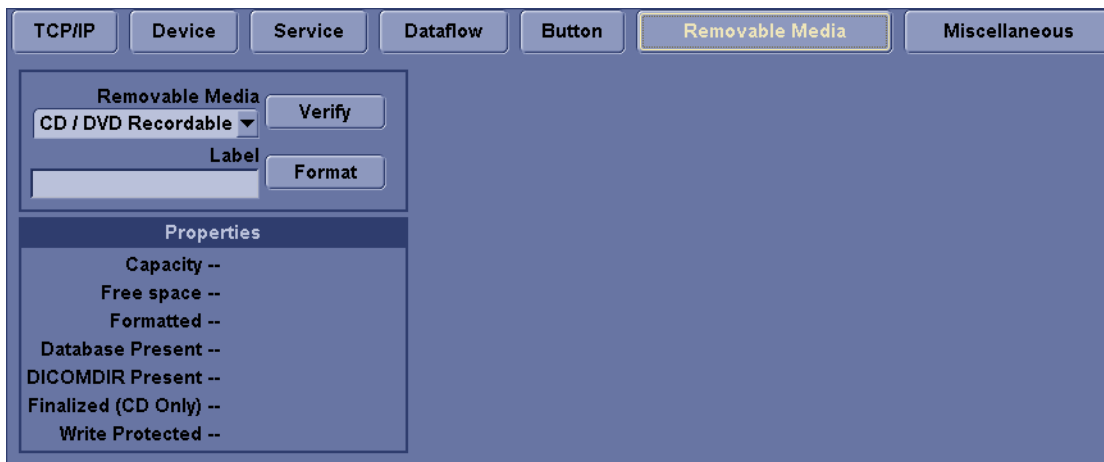

Figure 4-20 Format CD Screen

- 5.) Select Backup/Restore, then EZBackup/Move.
- 6.) Select "Backup File Older Than in Days".

Choose the days which want to older than current exam date.

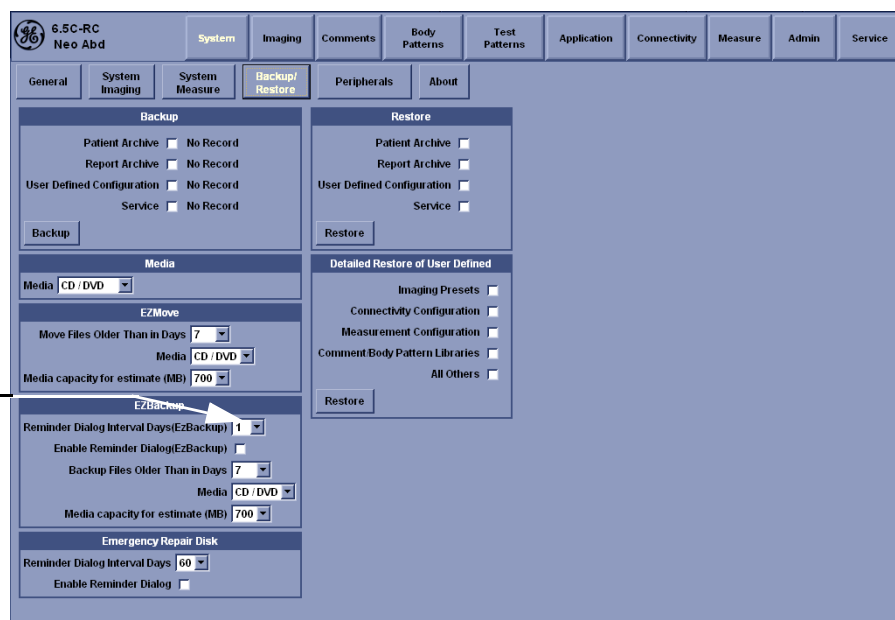

Figure 4-21 EZBackup/Move
Chapter 4 Functional Checks

4-3-14-4

Archiving Images (cont'd)

- 7.) Press **PATIENT** and set the Dataflow to store images directly to CD-ROM.
- 8.) From the image screen, press **EZBACKUP/MOVE**. The Move Images pop-up appears.

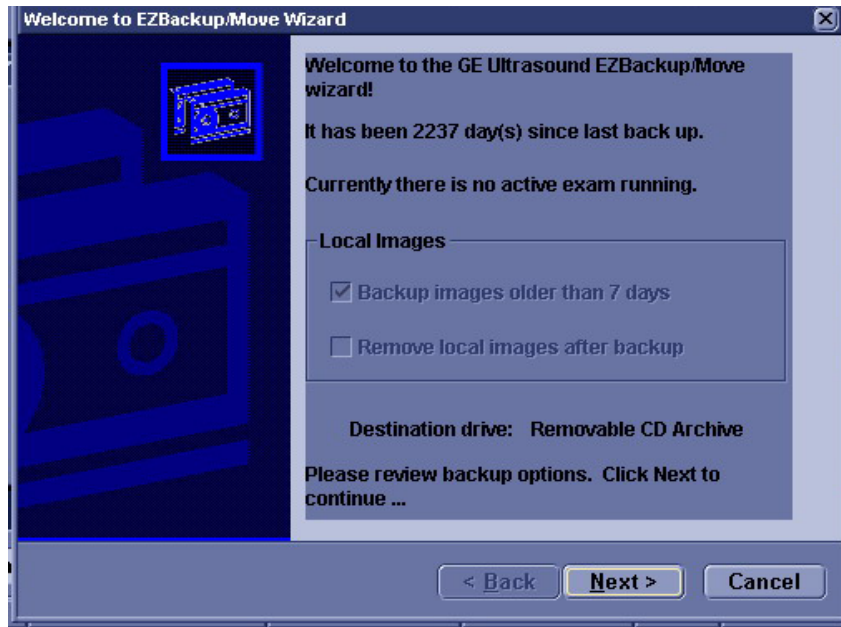

Figure 4-22 Image Archive Move Pop-up Menu

- 9.) Press **Next** on pop-up message.
- 10.) A media check message appears. Press **OK** to continue.

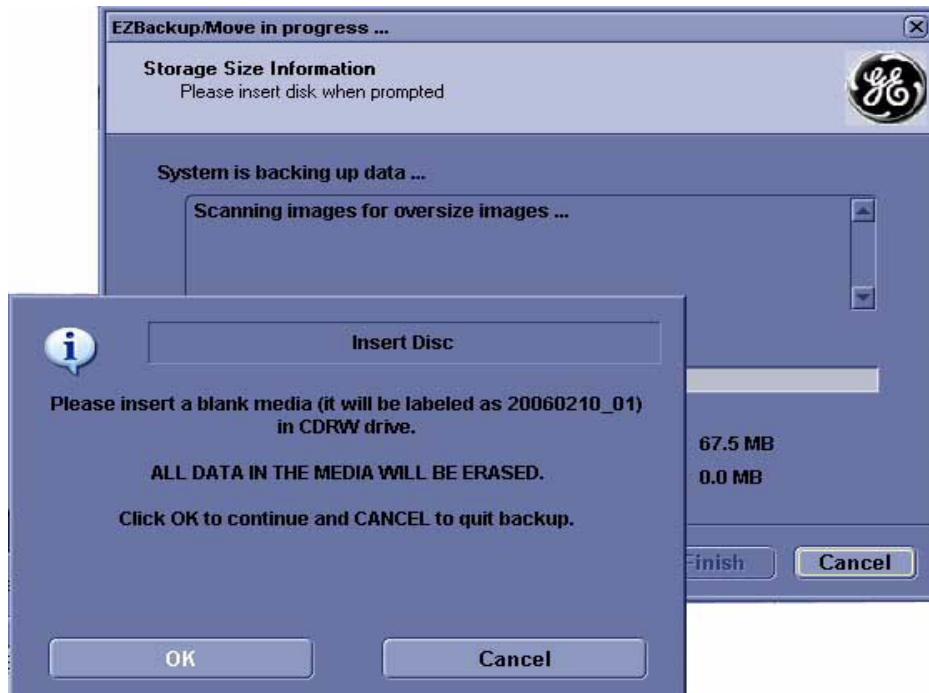

Figure 4-23 Media check message

- 4-3-14-4 **Archiving Images** (cont'd)
11.) Press **Finish** after Backup/Move complete.

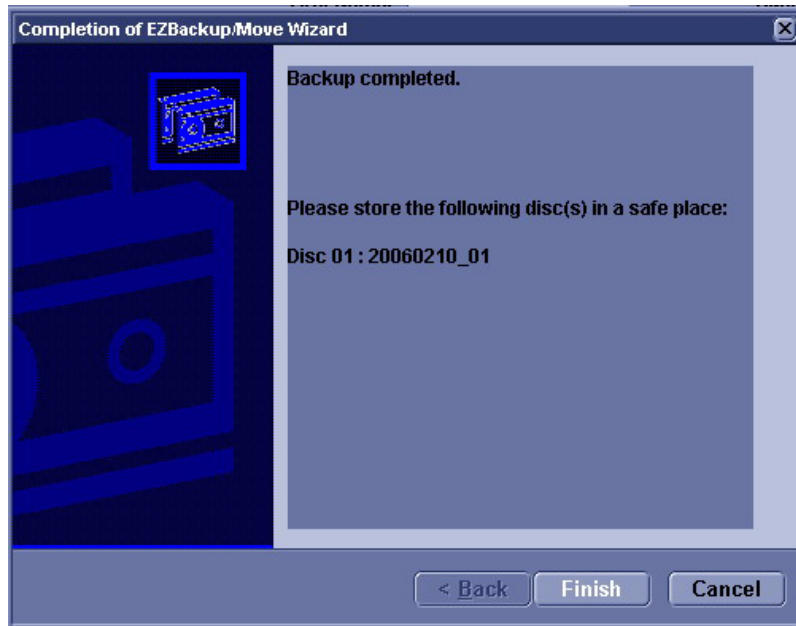

Figure 4-24 EZBackup/Move complete

All databases, presets and images should now be saved to removable media.

4-3-14-5 **Full Backup**

- 1.) Connect the USB HDD to system.
- 2.) Select Backup/Restore, then Emergency Repair Disk.
- 3.) Select "Reminder Dialog Interval Days".

Reminder Dialog
Interval Days

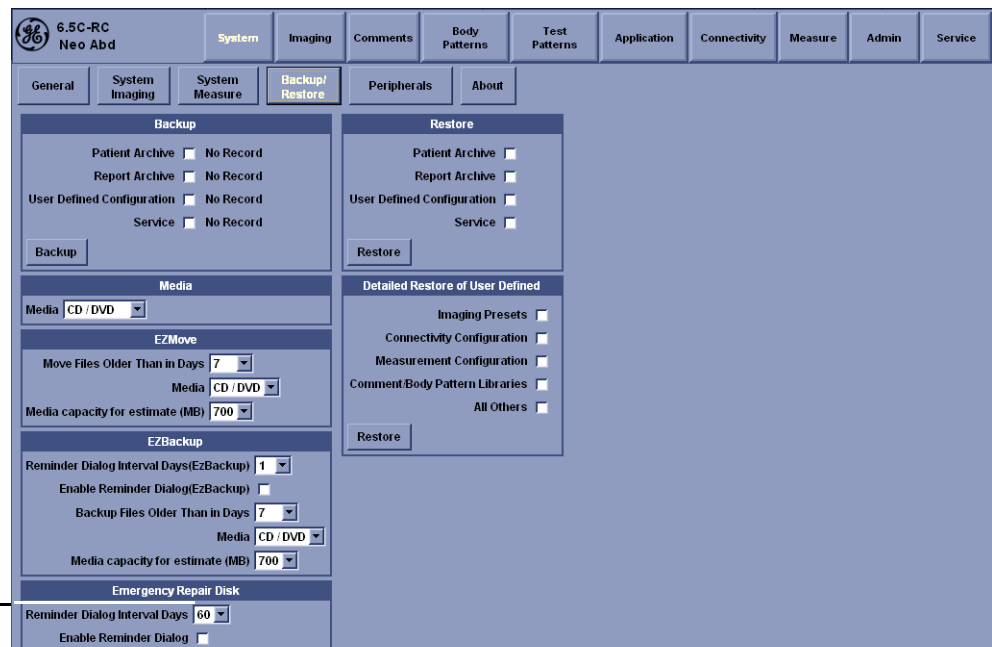

Figure 4-25 Emergency Repair Disk

4-3-14-5

Full Backup (cont'd)

4.) Return to scan mode. Press Ctrl + B, the Emergency Disk Making window pop-up appears.



Figure 4-26 Emergency Disk Making Pop-up Menu

5.) Press N on pop-up message.

6.) A storage information message appears. Press N to continue.

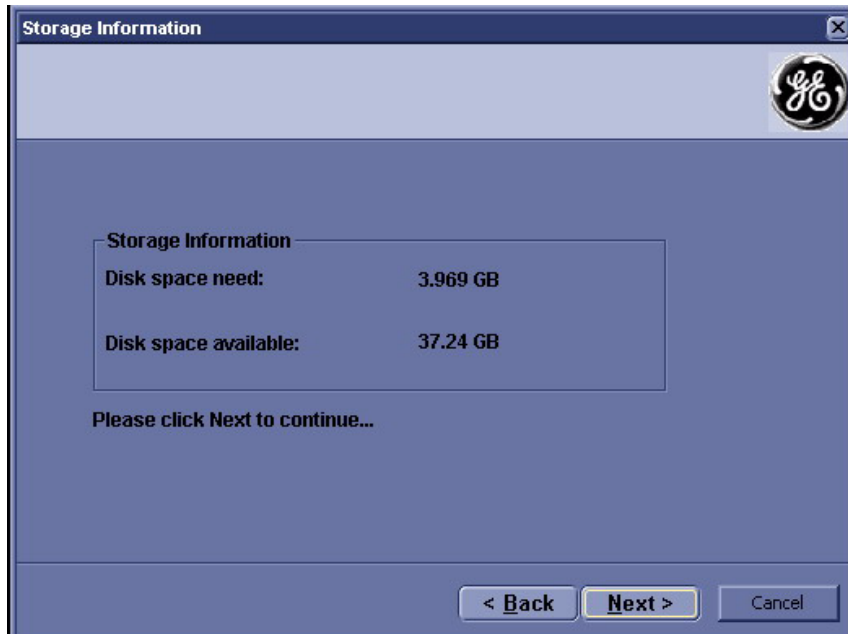

Figure 4-27 Storage Information message

4-3-14-5 **Full Backup** (cont'd)

7.) Press **Finish** after Emergency Disk Making complete.

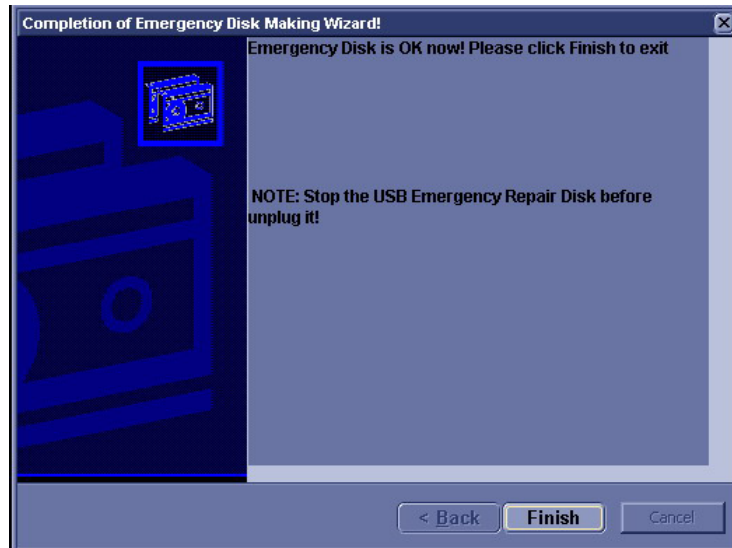

Figure 4-28 Emergency Disk Making Complete

All databases, presets and images should now be saved to Emergency Disk.

8.) Press Ctrl + R, Emergency Disk Recovery window pop-up appear.

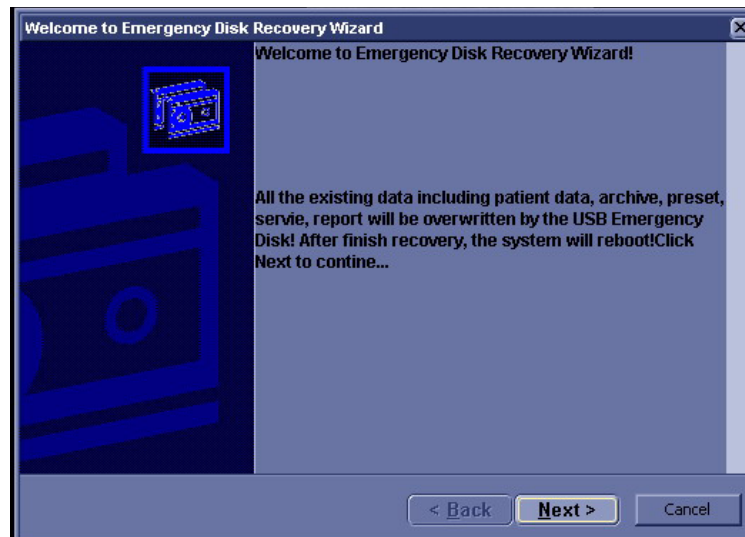

Figure 4-29 Emergency Disk Recovery

9.) Press **Next** on pop-up message.

4-3-14-5

Full Backup (cont'd)

10.) A recovery information message appears. Press Next to continue.

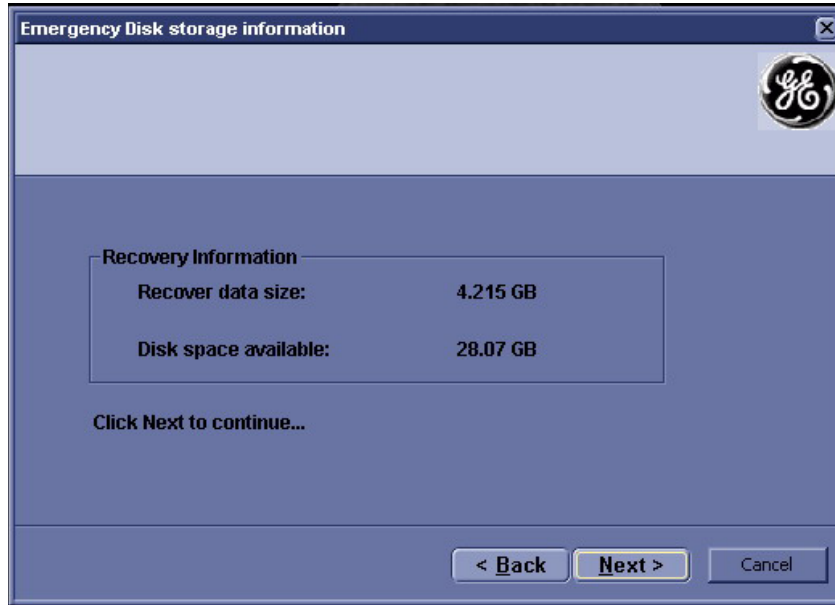

Figure 4-30 Recovery Information message

11.) Press Finish after Emergency Disk Recovery complete.

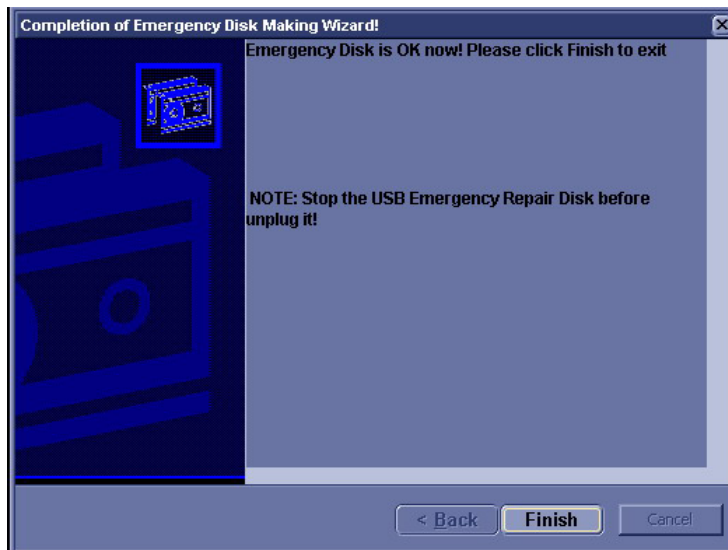

Figure 4-31 Emergency Disk Recovery Complete

1.)

Section 4-4 Software Configuration Checks

Table 4-11 Software Configuration Checks

Step	Task to do	Expected Result(s)
1.	Check Date and Time setting	Date and Time are correct
2.	Check that Location (Hospital Name) is correct	Location Name is correct
3.	Check Language settings	Desired Language is displayed
4.	Check assignment of Printer Keys	The default function for Store and Print Keys are Store (store image), Print (print). Store and Print Keys can also be assigned as desired by the customer
5.	Check that all of the customer's options are set up correct	All authorized functions are enabled

Section 4-5 Peripheral Checks

Check that peripherals work as described below:

Table 4-12 Peripheral Checks

Step	Task to do	Expected Result(s)
1.	Press (FREEZE)	Stop image acquisition.
2.	Press (PRINT) on the Control Panel	The image displayed on the screen is printed on B&W printer.
3.	Connect with Foot Switch on USB port and press once.	To start image acquisition (the same function as (FREEZE) key).

This page was intentionally left blank.

Chapter 5

Components and Functions (Theory)

Section 5-1 Overview

5-1-1 Purpose of Chapter 5

This chapter explains LOGIQ C Series' system concepts, component arrangement, and subsystem function.

Table 5-1 Contents in Chapter 5

Section	Description	Page Number
5-1	"Overview"	5-1
5-2	"Block Diagram"	5-2
5-3	"Common Service Platform"	5-4

Section 5-2 Block Diagram

5-2-1 System Diagram

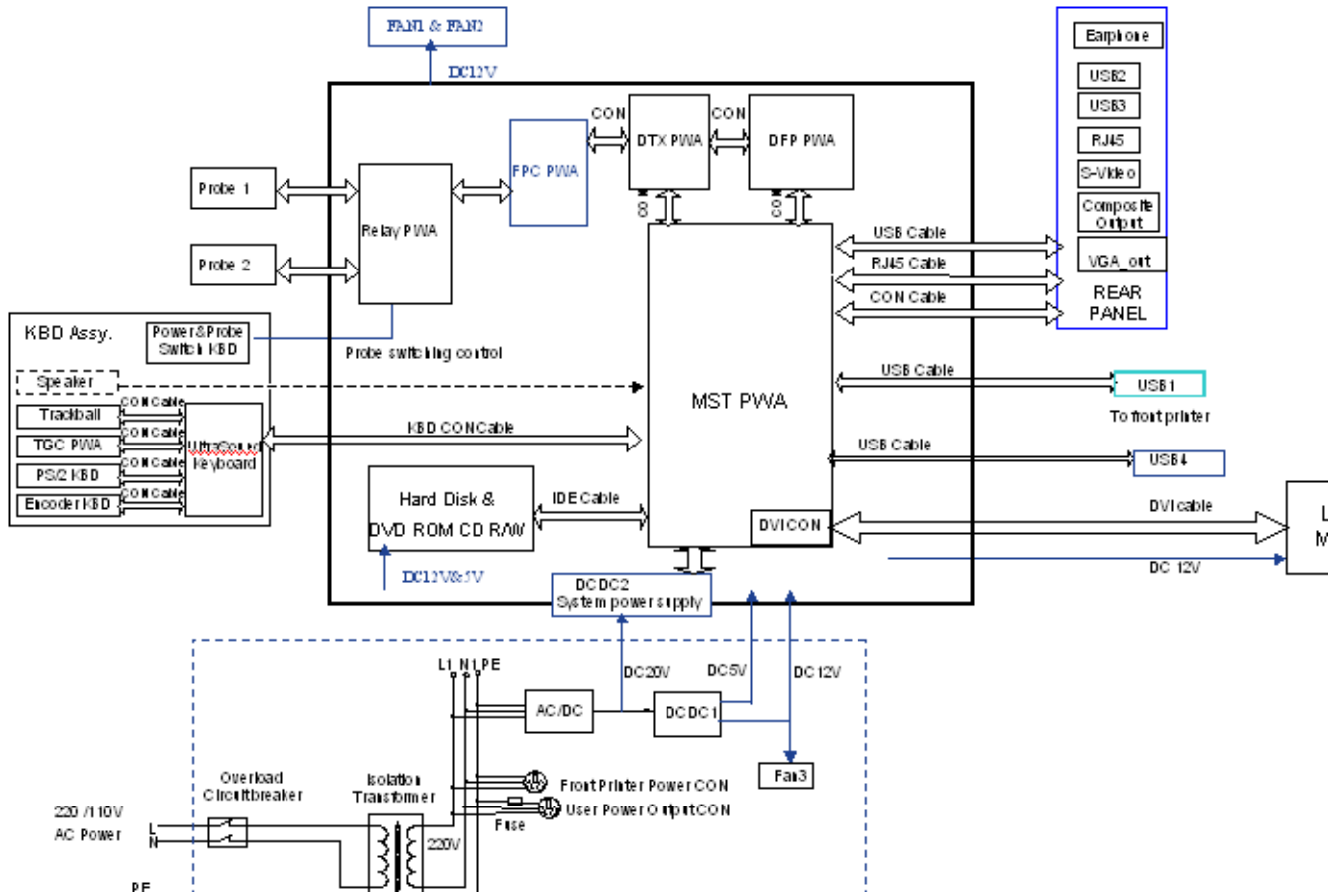

Figure 5-1 LOGIQ C Series System Diagram

5-2-2 Software Diagram

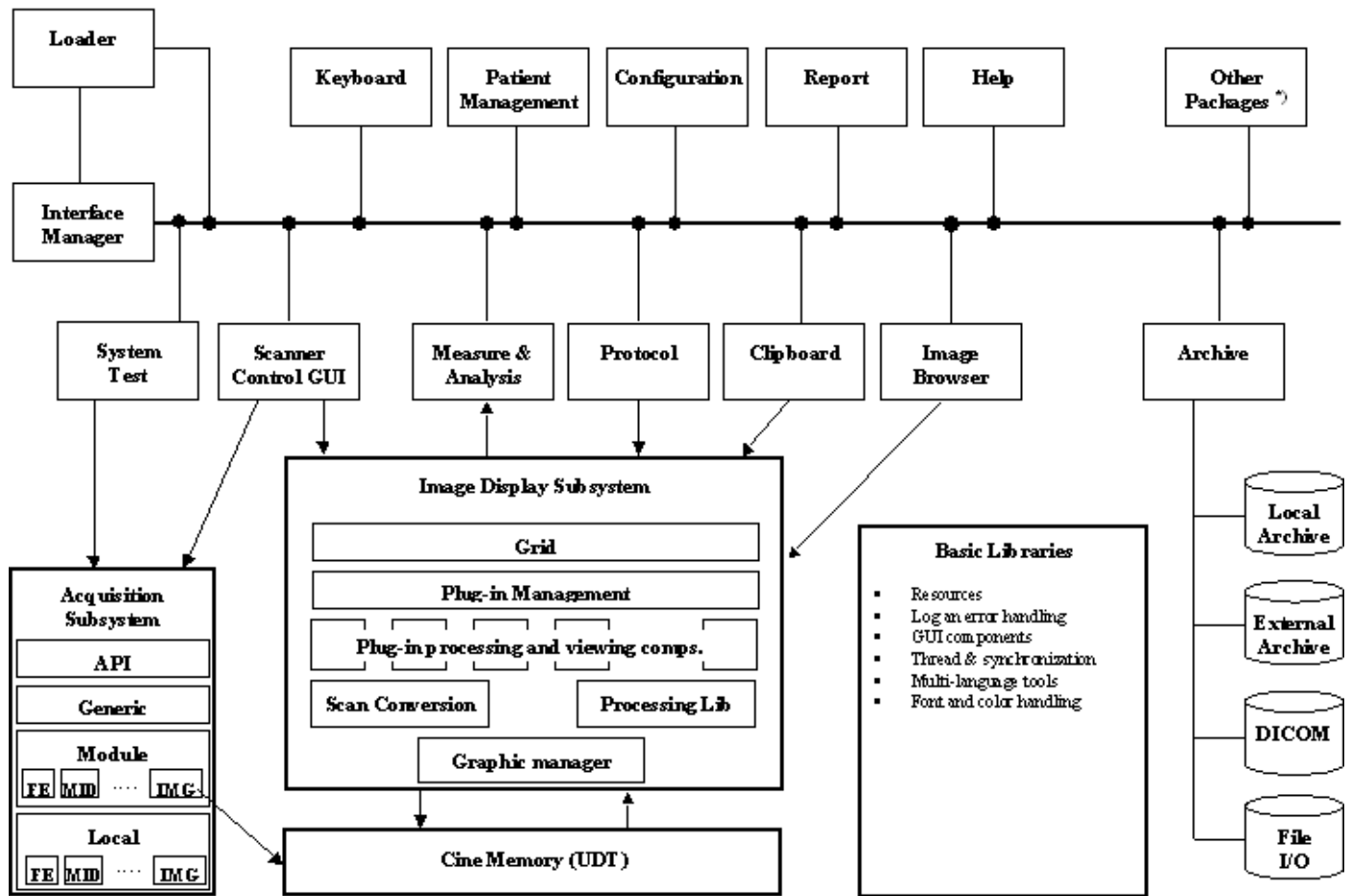

Figure 5-2 LOGIQ C Series Software Diagram

Section 5-3 Common Service Platform

5-3-1 Introduction

The Service Platform contains a set of software modules that are common to all PC backend ultrasound and cardiology systems. The Common Service Platform will increase service productivity and reduce training and service costs.

Chapter 6

Service Adjustments

Section 6-1 Overview

6-1-1 Purpose of this chapter 6

This section describes how to test and adjust the scanner. These tests are optional. You may use them to check the system for errors.

Table 6-1 Contents in chapter

Section	Description	Page Number
6-1	"Overview"	6-1
6-2	"Monitor Adjustments"	6-2

Section 6-2 Monitor Adjustments

6-2-1 Adjustments Procedures

To adjust the brightness:

For LOGIQ C2/C2 PRO: Adjust the LCD monitor's button, located the right side of the LCD Monitor.

For LOGIQ C3/C3 PRO and LOGIQ C5/C5 PRO: Adjust the LCD monitor's button, located the bottom of the LCD Monitor.

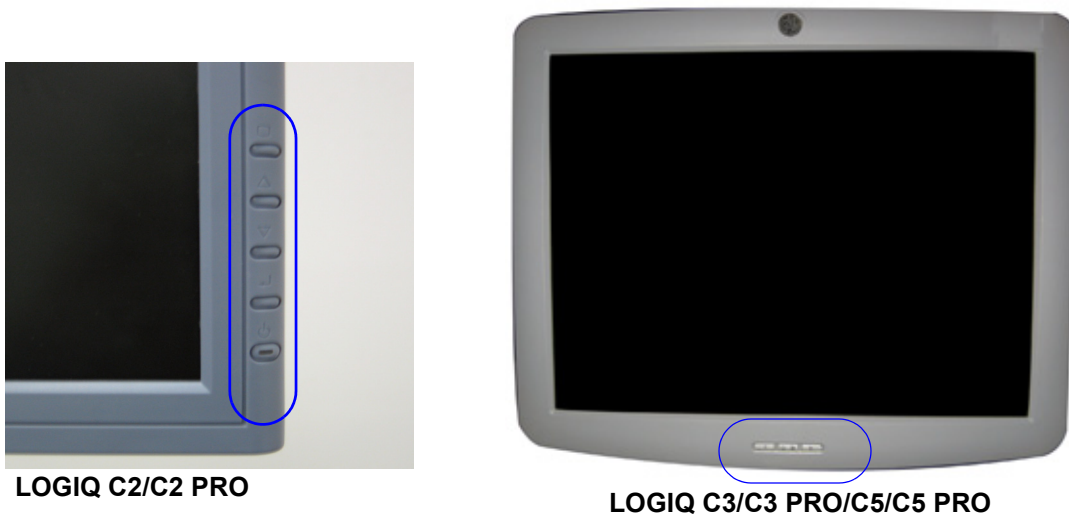

Figure 6-1 LCD Monitor

To adjust the light:

NOTE: If the left side button of the monitor has the light symbol, the LCD has the lights to light the keyboard.

For LOGIQ C3/C3 PRO and LOGIQ C5/C5 PRO: Adjust the left side button of the monitor to turn on/off the light.

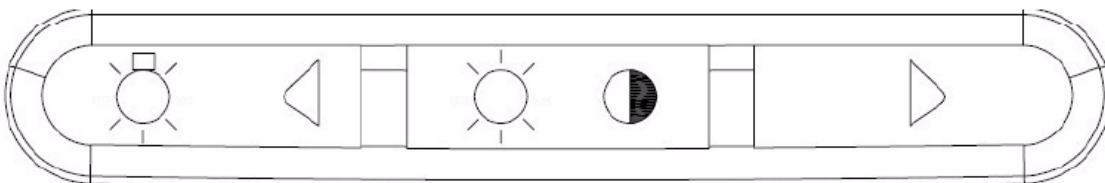

Figure 6-2 Light Adjustment

Chapter 7

Diagnostics/Troubleshooting

Section 7-1 Overview

7-1-1 Purpose of Chapter 7

This section describes how to setup and run the tools and software that help maintain image quality and system operation. Very basic host, system and board level diagnostics are run whenever power is applied. Some Service Tools may be run at the application level. However most software tests are required.

Table 7-1 Contents in Chapter 7

Section	Description	Page Number
7-1	"Overview"	7-1
7-2	"Gathering Trouble Data"	7-2
7-3	"USB Quick Save"	7-4
7-4	"Screen Captures"	7-6
7-5	"Common Diagnostics"	7-9
7-6	"Network Configuration"	7-12

Section 7-2 Gathering Trouble Data

7-2-1 Overview

There may be a time when it would be advantageous to capture trouble images and system data (logs) for acquisition to be sent back to the manufacturer for analysis. There are different options to acquire this data that would give different results.

7-2-2 Collect Vital System Information

The following information is necessary in order to properly analyze data or images being reported as a malfunction or being returned to the manufacturer:

- Product Name = LOGIQ C Series

From the *Utility>System>General>About* screen:

Applications Software

- Software Version
- Software Part Number

System Image Software

- Image Revision
- Image Part Number

7-2-3 Collect a Trouble Image with Logs

If the system should malfunction, press the Alt-D keys simultaneously. This will collect a screen capture of the image monitor, system presets and the following logs:

- Keyboard Shadow Log
- Error Logs
- Crash Log
- Power Supply
- Temperature

NOTE: *Power Supply and Temperature logs are not currently being updated by the LOGIQ C Series.*

This Alt-D function is available at all times.

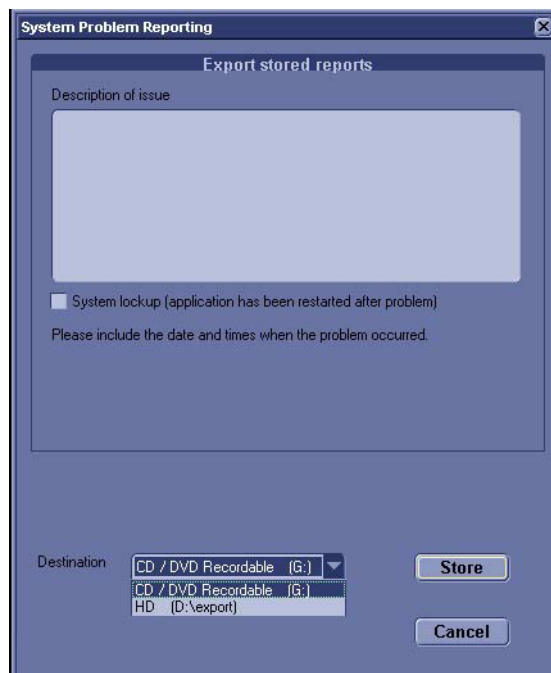

Figure 7-1 ALT-D Dialog Box

When Alt-D is pressed, a menu box appears that allows for:

- A place to enter a description of the problem
- A choice to store to a pre-formatted CD-R, RD (Removable Disk) or to the *Export* directory D: drive.

The subsequent file is compressed and time stamped. The screen capture is a bitmap which eliminates the possibility of artifacts from compression.

Section 7-3 USB Quick Save

NOTE: USB Quick Save function not support by LOGIQ C2/C2 PRO.

7-3-1 Overview

There may be times when the customer or field engineer will want to directly save images into USB memory. This is accomplished by saving individual Cine clips (moving images- avi format) or still images (jpg format) directly to a USB memory disk by pressing Print or Store Key.

There's no factory default print key to accomplish USB Quick Save. However, customer may have customize Print and Store Key function.

When performing a USB Quick Save, you can only define one USB Quick Save operation with either Print or Store keys.

NOTE: The print key that has been assigned to the USB Quick Save function should not have any other service functions assigned to it.

7-3-2 Check and Record the Print or Store Key Function

Check the function of the Print or Store Key in the event that the customer may have made some custom settings.

- 1.) Click *Utility* on the keyboard.
- 2.) Select *Connectivity* from the Utilities Menu.
- 3.) Select the *Buttons* tab on the Connectivity screen.
- 4.) In the *Physical Print Buttons* field, select Print or Store.

The Connectivity/Buttons Screen will be displayed like the one shown below.

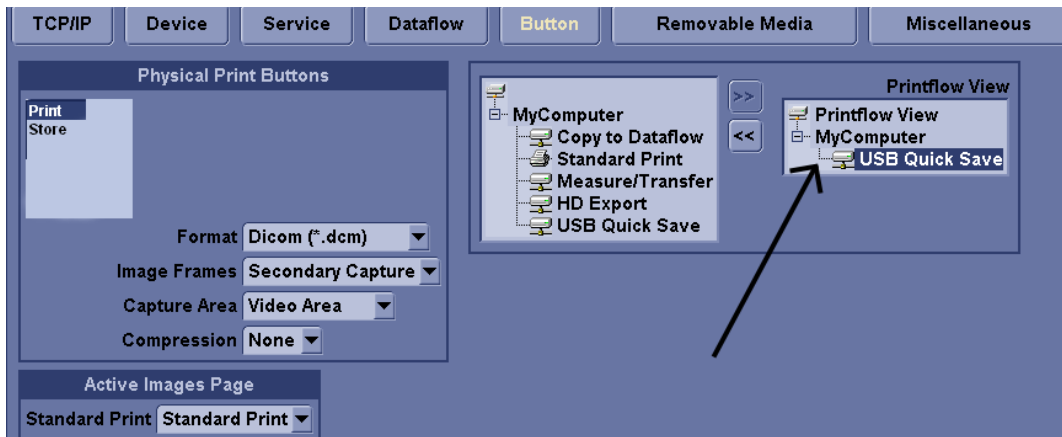

Figure 7-2 Defining Print or Store Key Operation

If Print or Store key is not set to Image Area, proceed to step 5 to record the customer's customized settings.

- 5.) In the Destinations section, record the service that is displayed.
- 6.) In the *Physical Print Buttons* section, record the parameters related to the service.

7-3-3 Setting the Print or Store Key to USB Quick Save

If the Print or Store Key is not set to screen capture:

- 1.) While on the Connect screen, with the Buttons tab displayed, go to the *Destinations* list.
- 2.) From the list select *USB Quick Save*. Press [>>] to add the selection to the *Printflow View* section.
- 3.) Ensure that the *Physical Print Buttons* section for capture Area is set to Image Area and No Image Compression.
- 4.) The Print and Store Key should now be set up for USB Quick Save, sending the images directly to the USB memory.



NOTICE It is unable to get full screen using USB Quick Save, just Image Area is available.

Section 7-4 Screen Captures

NOTE: *Screen Capture not support by LOGIQ C2 PRO/C3 PRO/C5 PRO.*

There may be times when the customer or field engineer will want to capture a presentation on the screen. This is accomplished by first saving the image(s) to the clipboard using a Print or Store Key.

The Store key is the factory default print key to accomplish a secondary Screen Capture. However, the customer may have customized the Store Key function.

7-4-1 Check and Record the Store Key Function

Check the function of the Store Key in the event that the customer may have made some custom settings.

- 1.) Click *Utility* on the keyboard.
- 2.) Select *Connectivity* from the Utilities Menu.
- 3.) Select the *Buttons* tab on the Connectivity screen.
- 4.) In the *Physical Print Buttons* field, select Store.

The Connectivity/Buttons Screen will be displayed like the one shown in [Figure 7-2 on page 7-4](#) .

If Store key is not set to Whole Screen, as shown in [Figure 7-2](#), proceed to step 5 to record the customer's customized settings.

- 5.) In the Destinations section, record the service that is displayed.
- 6.) In the *Physical Print Buttons* section, record the parameters related to the service.

7-4-2 Setting the Store Key to Screen Capture

If the Store Key is not set to screen capture:

- 1.) While on the Connect screen, with the Buttons tab displayed, go to the *Destinations* list.
- 2.) From the list select *Copy To Dataflow*. Press [>>] to add the selection to the *Printflow View* section.
- 3.) Ensure that the *Physical Print Buttons* section for capture Area is set to Whole Screen, secondary Capture and No Image Compression.
- 4.) The Store Key should now be set up for whole screen capture, sending the screens to the image buffer (clipboard).

7-4-3 Capturing a Screen

The following is a generic process to capture any screen from the scanner:

- 1.) Navigate to and display the image/screen to be captured.
- 2.) Press **STORE**. This will place a snapshot of the screen on the "clipboard" displayed at the bottom of the scan image display.

7-4-3 Capturing a Screen (cont'd)



Figure 7-3 Select Image to Capture

- 3.) Click FREEZE to unfreeze the image to view the image screen and the snapshots displayed on the bottom.
- 4.) Highlight the snapshot to be stored to RD (Removable Disk) or CD-R.
- 5.) Select Menu on the right side of the image screen, then highlight and select SAVE AS.



Figure 7-4 Menu > Save As

7-4-3 Capturing a Screen (cont'd)

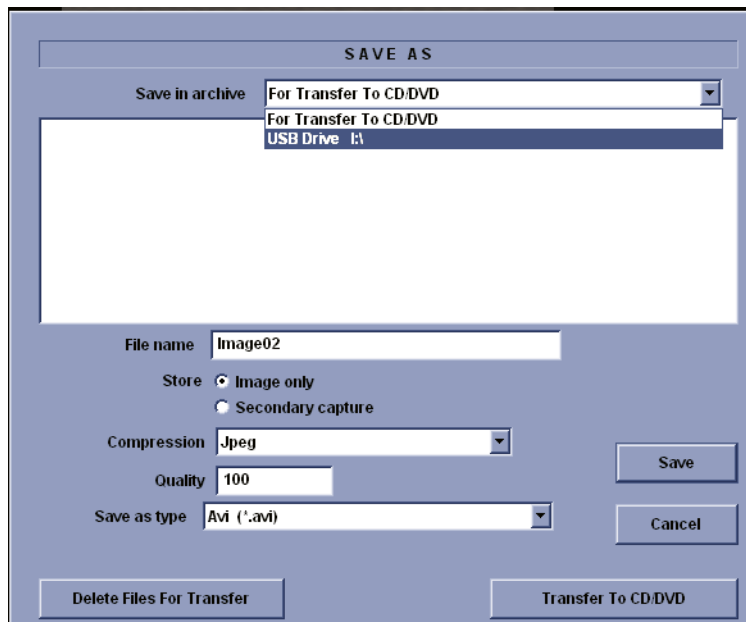



Figure 7-5 Save Dialog Box

- 6.) A Save dialog box will be opened. Choose *d:\export folder* as the archive location to save the image on the hard disk or CD-R.

 **NOTICE** After capture the snapshot of the screen to the “clipboard” and save it to the hard disk or other media, it is not full screen image on the hard disk or media.

7-4-4 Reset the Store Key to Customer’s Functionality

If the customer had programmed the Store Key to a function other than screen capture, restore that functionality recorded in [section 7-3-2 on page 7-4](#). Refer to [Figure 7-2](#).

- 1.) Click *Utility* on the keyboard.
- 2.) Select *Connectivity* from the Utilities Menu.
- 3.) Select the *Buttons* tab on the Connectivity screen.
- 4.) In the *Physical Print Button* field, select *Store*.
- 5.) In the *Destinations* list, select the service(s) recorded in [step 5](#), Section [7-3-2](#).
- 6.) In the *Physical Print Buttons* section, select the parameters related to the service recorded in [step 6](#), Section [7-3-2](#).

Section 7-5 Common Diagnostics

7-5-1 Utilities

Provides two selections:

7-5-1-1 Disruptive Mode

Allows you to enable or disable disruptive mode troubleshooting.

7-5-1-2 System Shutdown

Allows for system shutdown from the diagnostic menu. Select to *Restart System* or *Shutdown System*. Also, select to retain Disruptive Mode or Not.

After submitting to restart or shutdown a confirmation screen gives one last chance to confirm or cancel the request.

7-5-2 PC Diagnostics (Non-Interactive Tests)

7-5-2-1 Essential Tests

7-5-2-2 System Board

7-5-2-3 Hard Disk Surface Scan

7-5-2-4 Hard Disk Quick Test

7-5-2-5 PCIBus

7-5-2-6 Video Card

7-5-2-7 Network Interface

7-5-2-8 CMOS

7-5-2-9 DRAM Memory

7-5-2-10 Parallel Port

7-5-3 PC Diagnostics (Interactive Tests)**7-5-3-1 Keyboard Test****7-5-3-2 Mouse Test****7-5-4 Restart LOGIQ C Series After Diagnostics**

Always shutdown the system and reboot after a diagnostics session.

Section 7-6 Network Configuration

7-6-1 Network Configuration

7-6-1-1 Wire-LAN Network

- 1.) Connect system with network.
- 2.) Press Utility -> Connectivity -> TCPIP, in IP Settings window check the Enable DHCP box. In Network Speed box, choose the proper speed available.

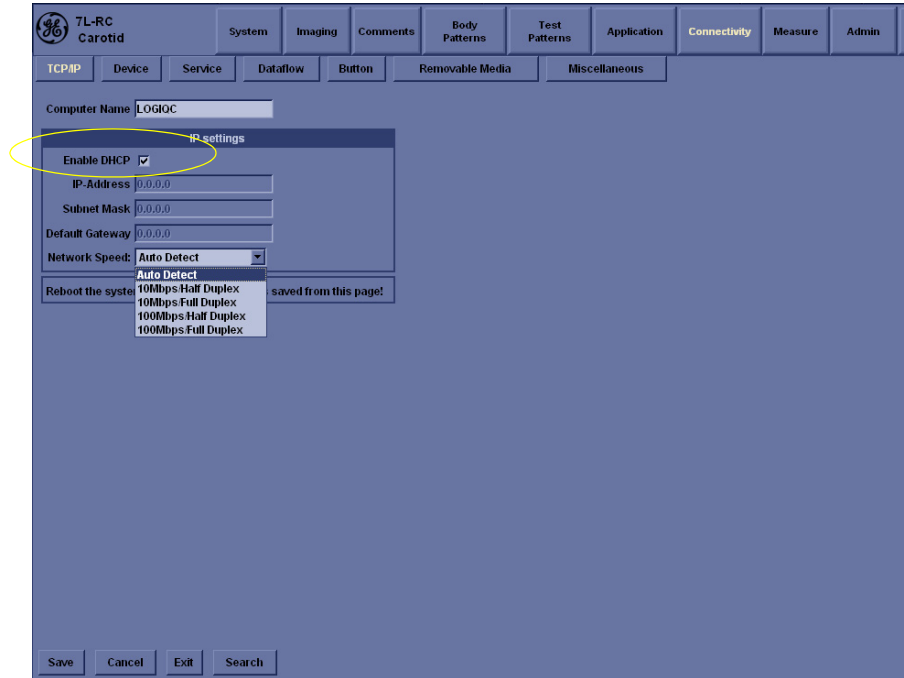

Figure 7-6 Enable DHCP

7-6-1-1 Wire-LAN Network (cont'd)

NOTE: If user want to setup static IP address, uncheck Enable DHCP option, input static address in IP-Address box, Subnet Mask and Default Gateway box. In Network Speed box, choose the proper speed available.

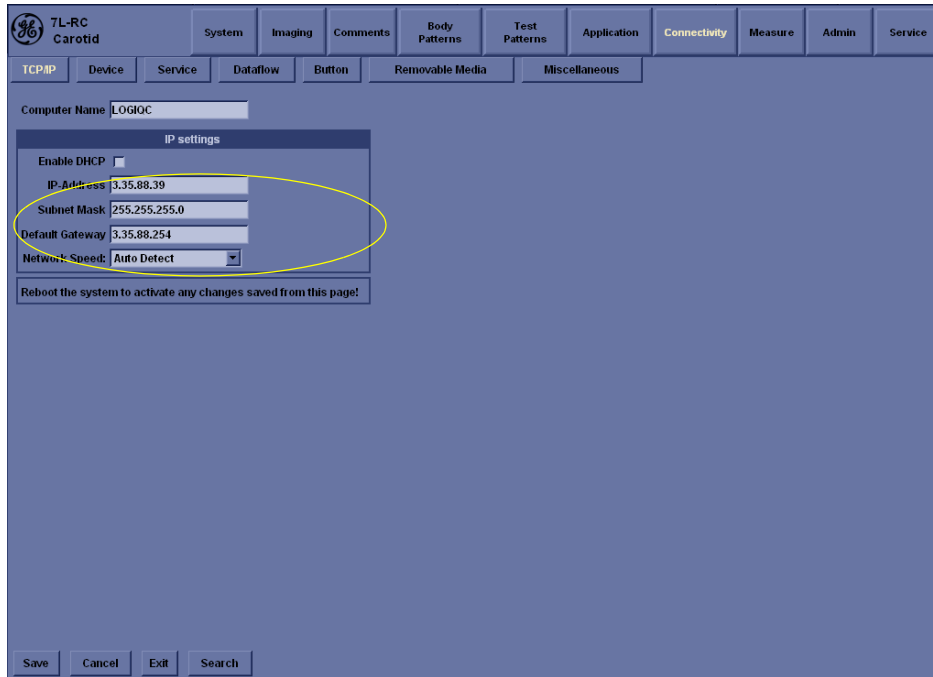

Figure 7-7 Input static address

3.) Click Save, in popped-up dialog choose Shutdown.

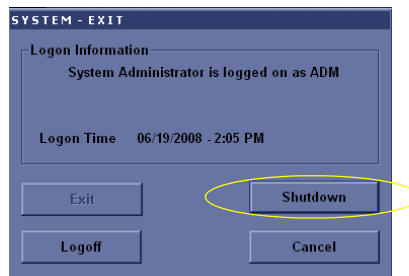

Figure 7-8 Save and reboot inquiry dialog

- 4.) After the system shutdown, reboot the system.
- 5.) After reboot, the network icon at the left bottom of screen turns green.

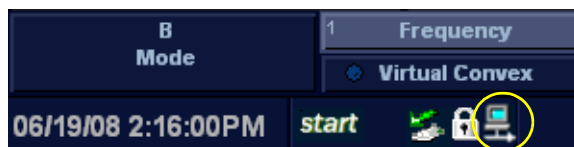

Figure 7-9 Network icon

This page was intentionally left blank.

Chapter 8

Replacement Procedures

Section 8-1 Overview

8-1-1 Purpose of Chapter 8

This chapter describes replacement procedures for the following modules and subsystems.

Table 8-1 Contents in Chapter 8

Section	Description	Page Number
8-1	"Overview"	8-1
8-2	"DISASSEMBLY/RE-ASSEMBLY"	8-2
8-2-1	"Warning and Caution"	8-2
8-2-2	"Air filter and Knob Screw (FRU No. 5030)"	8-2
8-3	"Loading Base Image Software"	8-3

Section 8-2 DISASSEMBLY/RE-ASSEMBLY

8-2-1 Warning and Caution

 **WARNING** *ONLY QUALIFIED SERVICE PERSONNEL SHOULD REMOVE ANY COVERS OR PANELS. ELECTRICAL HAZARDS EXISTS AT SEVERAL POINTS INSIDE. BECOME THOROUGHLY FAMILIAR WITH ALL HAZARDOUS VOLTAGES AND HIGH CURRENT LEVELS TO AVOID ACCIDENTAL CONTACT*

 **CAUTION** Do not wear the ESD wrist strap when you remove a part of power supply unit. Turn OFF power and unplug the power cord before removing a part of power supply unit. However be sure to turn off power and wear the strap before you remove a circuit boards.

 **WARNING** *DO NOT SERVICE OR DISASSEMBLE PARTS UNDER FRU UNIT LEVEL AT ANY CIRCUMSTANCES.*

8-2-2 Air filter and Knob Screw (FRU No. 5030)

8-2-2-1 Tools

- Common phillips screwdrivers

8-2-2-2 Preparations

- Shut Down the System and disconnect the power cord.

8-2-2-3 Removal Procedure

- 1.) Unscrew the knob screw which fix air filter on the edge of power box.
- 2.) Pull out the air filter.

8-2-2-4 Mounting procedure

Install the new parts in the reverse order of removal.



Figure 8-1 Air filter and Knob Screw Disassembly

Section 8-3 Loading Base Image Software

NOTE: While it is believed to be unnecessary, it would not hurt to disconnect the system from the network and remove all transducers.

NOTE: Please ensure power cable is connected during system upgrade!

- 1.) Insert the disk labeled "System & Application Software" into the DVD ROM drive.
- 2.) Properly turn off the scanner by momentarily pressing the *Power On/Off* Switch. Select "Shut Down" from the System Exit menu.
- 3.) If the system will not shutdown normally, hold down the *Power On/Off* Switch until the light turns from green to amber.
- 4.) Turn on the system. System will detect the DVD-RW automatically.
- 5.) Press any key to continue when below message display as shown below.

```
**** WARNING * WARNING * WARNING * WARNING * WARNING * WARNING ****  
  
THIS PROCEDURE MAY RESULT IN COMPLETE PATIENT DATA LOSS IF NOT USED  
CORRECTLY! PLEASE READ THE OPTIONS BELOW CAREFULLY BEFORE PROCEEDING.  
  
This process is NOT REVERSIBLE and should NOT be stopped once started!  
DO NOT power off the system until the process has completed. It will  
take less than 10 minutes to load the drive. IF this process IS stopped  
for some reason, you WILL have to run it again to completion or else the  
system will not work.  
  
If you want to proceed with this process press the "Enter" key to  
continue with option selection.  
  
...OR...  
  
Remove the CDROM from the CDROM drive and Press "CTRL-C" now to exit and  
power cycle your system to restart it without overwriting your disk drive's  
current contents.  
  
Press any key to continue . . .
```

Figure 8-2 Upgrade message

Section 8-3 Loading Base Image Software (cont'd)

- 6.) Select one of the options for loading the system. Select choice 1] to load the complete disk.

```
*****
Please select ONE of the following options for loading the LOGIQ C2
"System and Application Software Load Image" onto your system:
*****

[1] Load the complete disk - All existing data will be lost.
    NOTE: APPLICATION SOFTWARE WILL NEED TO BE INSTALLED WHEN THIS PROCEDURE
          HAS COMPLETED. ALL PATIENT DATA (IF ANY) WILL BE DESTROYED!

[2] Load the bootable C: partition only - Patient data is NOT lost.
    NOTE: DO NOT USE THIS OPTION ON A BRAND NEW SYSTEM. IT IS
          INTENDED FOR RECOVERY OF A SYSTEM THAT WILL NOT BOOT UP.
          APPLICATION SOFTWARE WILL NEED TO BE INSTALLED WHEN THIS
          PROCEDURE HAS COMPLETED. ALL PATIENT DATA IS PRESERVED.

[3] Exit to the A:\ prompt.

Please make your selection from the above choices (1, 2, 3):
```

Figure 8-3 Selection for loading the system

 **WARNING** *While the software install procedure is designed to preserve data, you should select choice [2] to format disk C only.*

 **WARNING** *If software upgrades to R1.1.5 in China, you should select choice [1] to load or upgrade complete disk.*

- 7.) Press any key to continue when below message display as shown below.

```
You are about to reload the entire disk. If you DO NOT want to do this,
remove the CDROM from the CDROM drive and Press "CTRL-C" now to exit and
power cycle your system to restart without overwriting your disk drive's
current contents.

Press any key to continue . . .
```

Figure 8-4 Upgrade continue message

Section 8-3 Loading Base Image Software (cont'd)

8.) System CD will be loaded as shown in the screen below.

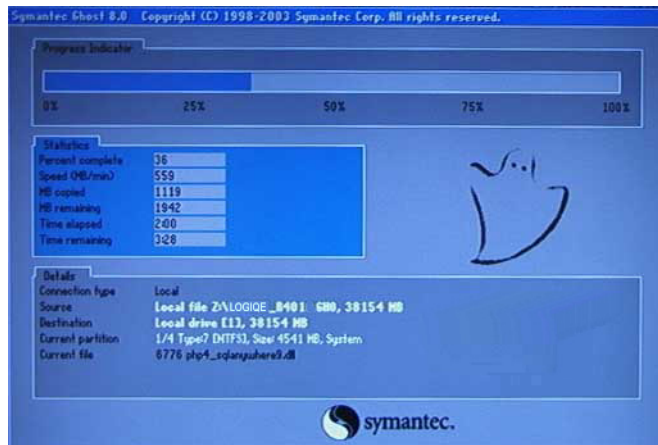

Figure 8-5 Upgrading message

9.) System updating finished, refer to [Figure 8-6 on page 8-5](#) .

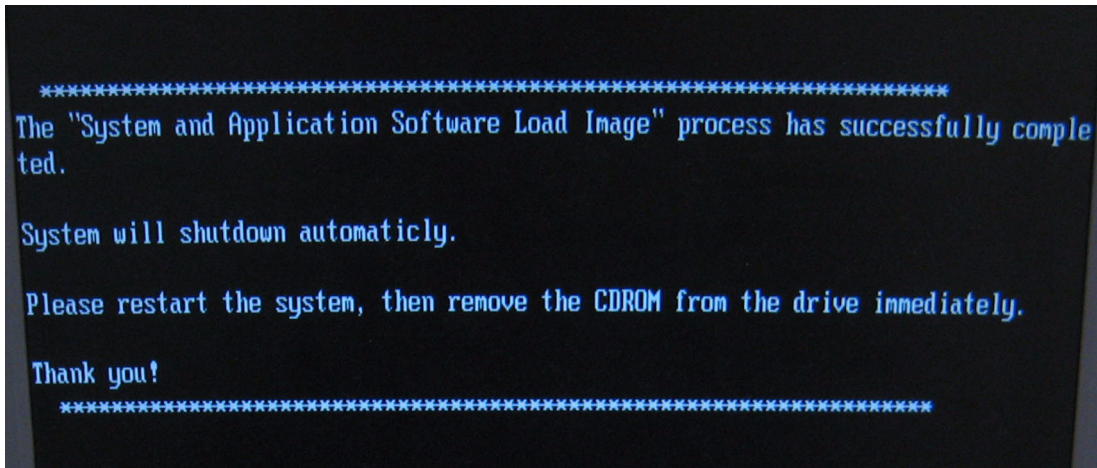

Figure 8-6 System upgrade complete

10.) Press power key to reboot system, then remove the CDROM from the drive immediately. When system first time boot up after upgrading complete, type Serial Number and Option Key before starting up.

This page was intentionally left blank.

Chapter 9

Renewal Parts

Section 9-1 Overview

9-1-1 Purpose of Chapter 9

This chapter gives you an overview of Renewal Parts for LOGIQ C Series.

Table 9-1 Contents in Chapter 9

Section	Description	Page Number
9-1	"Overview"	9-1
9-2	"List of Abbreviations"	9-1
9-3	"Renewal Parts Lists"	9-2
9-4	"Operator Console Assy"	9-3
9-5	"Keyboard Assy"	9-3
9-6	"Accessories and kits"	9-4
9-7	"Manuals"	9-6
9-8	"Probes"	9-7

Section 9-2 List of Abbreviations

- Assy - Assembly
- Ctrl - Control
- FRU 1 - Replacement part available in part hub
- FRU 2 - Replacement part available from the manufacturer (lead time involved)
- Int - Internal
- I/O - Input/Output
- LCD - Liquid Crystal Display
- MON - Monitor
- PAT. - Patient
- PC - Personal Computer (Back End Processor)

NOTE: The part replacement is shown by the item numbers. If the part is replaced by a new version, the item number for the new version will have a letter in the alphabetic order after the Arabic numerals. For example, item 300B is to replace item 300A, and item 300A is to replace item 300. So please refer to item numbers for the latest version of the parts.

Section 9-3Renewal Parts Lists

9-3-1 Equipment Models Covered in this Chapter

Table 9-2 ACDC Power Pack & ACDC Power Cable list

Item	Part Name	Part Number	Replaced By	Description	Quantity	FRU
001	AC Power Cord	5177123	5177123-2	Power cord Europe Class	1	1
	AC Power Cord	5176304	5176304-2	Power cord China Class	1	1
	AC Power Cord	5176773	5176773-2	Power cord India Class	1	1
	AC Power Cord	5177195	5177195-2	Power cord Argentina Class	1	1
	AC Power Cord	5176907	5176907-2	Power cord UK Class	1	1
	AC Power Cord	5177153	5177153-2	Power cord Denmark Class	1	1
	AC Power Cord	5177154	5177154-2	Power cord Switzerland Class	1	1
	AC Power Cord	5177187-2	5177187-3	Power cord Australia Class	1	1
	AC Power Cord	5177146	5177146-2	Power cord USA Class	1	1
	AC Power Cord	5400868	5400868-2	Power cord Brazilian Class	1	1
	AC Power Cord	5176753	5176753-2	Power cord Israel Class	1	1
001A	AC Power Cord	5177123-2		Power cord Europe Class	1	1
	AC Power Cord	5176304-2		Power cord China Class	1	1
	AC Power Cord	5176773-2		Power cord India Class	1	1
	AC Power Cord	5177195-2		Power cord Argentina Class	1	1
	AC Power Cord	5176907-2		Power cord UK Class	1	1
	AC Power Cord	5177153-2		Power cord Denmark Class	1	1
	AC Power Cord	5177154-2		Power cord Switzerland Class	1	1
	AC Power Cord	5177187-3		Power cord Australia Class	1	1
	AC Power Cord	5177146-2		Power cord USA Class	1	1
	AC Power Cord	5400868-2		Power cord Brazilian Class	1	1
	AC Power Cord	5176753-2		Power cord Israel Class	1	1
002	Power Cable Bracket	5224241-2		Power Cable Bracket	1	1

NOTE: The new revision AC power cord listed in item 001A must be ordered with power cable bracket 5224241-2.

Section 9-4 Operator Console Assy

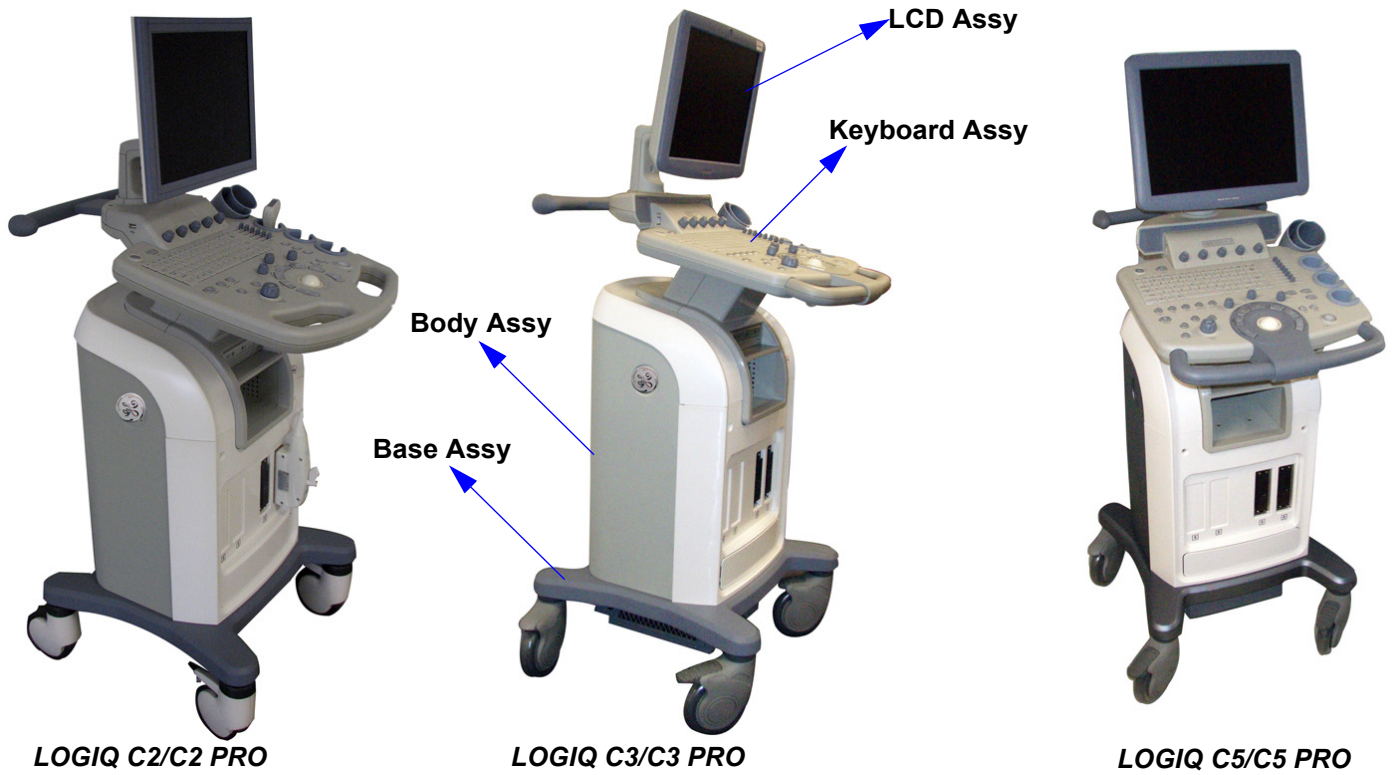

Figure 9-1 Operator Console Assy

Section 9-5 Keyboard Assy

Table 9-3 Keyboard Assy

Item	Part Number	Description	Qty	FRU
2000	5315715	LOGIQ C2/C2 PRO KBD Top Assy	1	1
	5315716	LOGIQ C3/C3 PRO KBD Top Assy	1	1
	5315717	LOGIQ C5/C5 PRO KBD Top Assy	1	1
	5315718	LOGIQ C2/C2 PRO KBD Top Assy For Russian	1	1
	5315719	LOGIQ C3/C3 PRO KBD Top Assy For Russian	1	1
	5315720	LOGIQ C5/C5 PRO KBD Top Assy For Russian	1	1

Section 9-6 Accessories and kits

Table 9-4 Accessories and Kits

Item	Part Number	Description	Qty	FRU
6020	5245387	LOGIQ C2/C2 PRO Cable Kits	1	2
	5248887	LOGIQ C3/C3 PRO/C5/C5 PRO Cable Kits	1	2
	5315692-2	Cable Kits_LOGIQ C2 for one Box unit	1	2
	5363645	Cable Kits_LOGIQ C3, C5 for one Box unit	1	2
6020A	5363645	Cable Kits_LOGIQ C3, C5 for one Box unit	1	2
	5363647	Cable Kits_LOGIQ C3, C5 for non-one Box unit	1	2
	5363642	Cable Kits_LOGIQ C2 for one Box unit	1	2
	5363641	Cable Kits_LOGIQ C2 for non-one Box unit	1	2
7010	5315707	Collector UPD897 kits	1	2
7021	5315282-3	LOGIQ C Series system and application DVD R112	1	2
7021A	5315282-4	LOGIQ C Series system and application DVD R113	1	2
7021B	5315282-5	LOGIQ C Series system and application DVD R114	1	2
7021C	5315282-6	LOGIQ C Series system and application DVD R115	1	2
7021D	5315282-7	LOGIQ C Series system and application DVD R116	1	2
7021E	5315282-8	LOGIQ C Series system and application DVD R117	1	2
7021F	5315282-9	LOGIQ C Series system and application DVD R118	1	2
7022	5315283-3	LOGIQ C PRO Series system and application DVD R112	1	2
7022A	5315283-4	LOGIQ C PRO Series system and application DVD R113	1	2
7022B	5315283-5	LOGIQ C PRO Series system and application DVD R114	1	2
7022C	5315283-6	LOGIQ C PRO Series system and application DVD R115	1	2
7022D	5315283-7	LOGIQ C PRO Series system and application DVD R116	1	2
7022F	5315283-8	LOGIQ C PRO Series system and application DVD R117	1	2
7022G	5315283-9	LOGIQ C PRO Series system and application DVD R118	1	2
7023	5336393	LOGIQ C Series system and application DVD R115 for China	1	2
7024	5391552-2	LOGIQ C Series system and application DVD R131	1	2

Table 9-4 Accessories and Kits

Item	Part Number	Description	Qty	FRU
7024A	5391552-3	LOGIQ C Series system and application DVD R132	1	2
7024B	5391552-4	LOGIQ C Series system and application DVD R133	1	2
7024C	5391552-5	LOGIQ C Series system and application DVD R134	1	2
7025	5391556-2	LOGIQ C PRO Series system and application DVD R131	1	2
7025A	5391556-3	LOGIQ C PRO Series system and application DVD R132	1	2
7025B	5391556-4	LOGIQ C PRO Series system and application DVD R133	1	2
7025C	5391556-5	LOGIQ C PRO Series system and application DVD R134	1	2
6031	5328133	Service Tools for LOGIQ C Series	1	4
6032	5324832	Support Jig for Service	1	1

Section 9-7Manuals

Item	Part Number	Description	Qty	FRU
	5273008-100	LOGIQ C Series Service Manual	1	N
System User Manuals				
	5265060 -100	User Manual, LOGIQ C2/C2 PRO, English	1	N
	5265060 -101	User Manual, LOGIQ C2/C2 PRO, French	1	N
	5265060 -106	User Manual, LOGIQ C2/C2 PRO, Spanish	1	N
	5265060 -108	User Manual, LOGIQ C2/C2 PRO, German	1	N
	5265060 -111	User Manual, LOGIQ C2/C2 PRO, Italian	1	N
	5265060 -127	User Manual, LOGIQ C2/C2 PRO, portuguese	1	N
	5265060 -141	User Manual, LOGIQ C2/C2 PRO, Chinese	1	N
	5265060 -177	User Manual, LOGIQ C2/C2 PRO, European portuguese	1	N
	5268001 -100	User Manual, LOGIQ C3/C3 PRO, English	1	N
	5268001 -101	User Manual, LOGIQ C3/C3 PRO, French	1	N
	5268001 -106	User Manual, LOGIQ C3/C3 PRO, Spanish	1	N
	5268001 -108	User Manual, LOGIQ C3/C3 PRO, German	1	N
	5265060 -111	User Manual, LOGIQ C3/C3 PRO, Italian	1	N
	5268001 -127	User Manual, LOGIQ C3/C3 PRO, portuguese	1	N
	5268001 -141	User Manual, LOGIQ C3/C3 PRO, Chinese	1	N
	5268001 -177	User Manual, LOGIQ C3/C3 PRO, European portuguese	1	N
	5268596 -100	User Manual, LOGIQ C5/C5 PRO, English	1	N
	5268596 -101	User Manual, LOGIQ C5/C5 PRO, French	1	N
	5268596 -106	User Manual, LOGIQ C5/C5 PRO, Spanish	1	N
	5268596 -108	User Manual, LOGIQ C5/C5 PRO, German	1	N
	5268596 -111	User Manual, LOGIQ C5/C5 PRO, Italian	1	N
	5268596 -127	User Manual, LOGIQ C5/C5 PRO, portuguese	1	N
	5268596 -141	User Manual, LOGIQ C5/C5 PRO, Chinese	1	N
	5268596 -177	User Manual, LOGIQ C5/C5 PRO, European portuguese	1	N
System Quick Start Guide				
	5271093 -100	Quick Start Guide, LOGIQ C2/C2 PRO	1	N
	5262559 -100	Quick Start Guide, LOGIQ C3/C3 PRO	1	N
	5272220 -100	Quick Start Guide, LOGIQ C5/C5 PRO	1	N

Section 9-8 Probes

Table 9-5 Probes on LOGIQ C Series

Item	Part Name	Part Number	Replaced By	Description	Quantity	FRU
8801	4C-RC	5315581		Probe (Center Frequency: 3.75MHz)	1	1
8802	3.8C-RC	5315682		Probe (Center Frequency: 3.75MHz)	1	1
8803	7L-RC	5315684		Probe (Center Frequency: 7.5MHz)	1	1
8804	7.5C-RC	5315683		Probe (Center Frequency: 7.5MHz)	1	1
8805	6.5C-RC	5315685		Probe (Center Frequency: 6.5MHz)	1	1
8806	E6C-RC	5315687		Probe (Center Frequency: 6.5MHz)	1	1
8807	E7C-RC	5315686		Probe (Center Frequency: 6.5MHz)	1	1
8808	3S-RC	5315689	5499957	Probe (Center Frequency: 2.0MHz)	1	1
8808A	3S-RC	5499957		Probe (Center Frequency: 2.0MHz)	1	1



NOTICE 3S-RC* is not available on LOGIQ C2/C2 PRO.



NOTICE All the spare parts should be disposed according to local laws.

This page was intentionally left blank.

Chapter 10

Care & Maintenance

Section 10-1 Overview

10-1-1 Periodic Maintenance Inspections

It has been determined by engineering that your system does not have any high wear components that fail with use, therefore no Periodic Maintenance Inspections are mandatory. Some Customers Quality Assurance Programs may require additional tasks and or inspections at a different frequency than listed in this manual.

10-1-2 Purpose of Chapter 10

This chapter describes **Care & Maintenance** on the scanner and peripherals. These procedures are intended to **maintain the quality** of the ultrasound **systems performance**. Read this chapter completely and familiarize yourself with the procedures before performing a task.

Table 10-1 Contents in Chapter 10

Section	Description	Page Number
10-1	"Overview"	10-1
10-2	"Why do Maintenance"	10-2
10-3	"Maintenance Task Schedule"	10-2
10-4	"Tools Required"	10-4
10-5	"When There's Too Much Leakage Current..."	10-20

 **CAUTION** Practice good ESD prevention. Wear an anti-static strap when handling electronic parts and even when disconnecting/connecting cables.

 **DANGER** **THERE ARE SEVERAL PLACES ON THE BACKPLANE, THE AC DISTRIBUTION, AND DC DISTRIBUTION THAT ARE DANGEROUS. BE SURE TO DISCONNECT THE SYSTEM POWER PLUG AND OPEN THE MAIN CIRCUIT BREAKER BEFORE YOU REMOVE ANY PARTS. BE CAUTIOUS WHENEVER POWER IS STILL ON AND COVERS ARE REMOVED.**

 **CAUTION** Do not pull out or insert circuit boards while power is ON.

 **CAUTION** Do not operate this unit unless all board covers and frame panels are securely in place. System performance and cooling require this.

Section 10-2 Why do Maintenance

10-2-1 Keeping Records

It is good business practice that ultrasound facilities maintain records of quality checks and corrective maintenance. The Ultrasound Inspection Certificate (provided on page 10-21) provides the customer with documentation that the ultrasound scanner is maintained on a periodic basis.

A copy of the Ultrasound Periodic Maintenance Inspection Certificate should be kept in the same room or near the scanner.

10-2-2 Quality Assurance

In order to gain accreditation from organizations such as the American College of Radiology (USA), it is the customer's responsibility to have a quality assurance program in place for each scanner. The program must be directed by a medical physicist, the supervising radiologist/physician or appropriate designee.

Routine quality control testing must occur regularly. The same tests are performed during each period so that changes can be monitored over time and effective corrective action can be taken.

Testing results, corrective action and the effects of corrective action must be documented and maintained on the site.

Your GE service representative can help you with establishing, performing and maintaining records for a quality assurance program. Please contact us for coverage information and/or price for service.

Section 10-3 Maintenance Task Schedule

10-3-1 How often should care & maintenance tasks be performed?

The Care & Maintenance Task Schedule (provided on page 10-3) specifies how often your LOGIQ C Series should be serviced and outlines items requiring special attention.

NOTE: It is the customer's responsibility to ensure the LOGIQ C Series care & maintenance is performed as scheduled in order to retain its high level of safety, dependability and performance.

Your GE Service Representative has an in-depth knowledge of your LOGIQ C Series ultrasound scanning system and can best provide competent, efficient service. Please contact us for coverage information and/or price for service.

The service procedures and recommended intervals shown in the Care & Maintenance Task Schedule assumes that you use your LOGIQ C Series for an average patient load (10-12 per day) and not use it as a primary mobile unit which is transported between diagnostic facilities.

NOTE: If conditions exist which exceed typical usage and patient load, then it is recommended to increase the maintenance frequencies.

Section 10-3 Maintenance Task Schedule (cont'd)

Table 10-2 Customer Care Schedule

Service at Indicated Time	Daily	Weekly	Monthly	Per Facilities QA Program	Notes
Clean Probe Holders	•				
Clean Air Filter		•			more frequently depending on your environment
Inspect AC Mains Cable			•		Mobile Unit Check Weekly
Inspect Cables and Connectors			•		
Clean Console			•		
Inspect Wheels, Casters, brakes and Swivel Locks			•		Mobile Unit Check Daily
Check Control Panel Movement			•		Mobile Unit Check Daily
Console Leakage Current Checks				•	also after corrective maintenance
Peripheral Leakage Current Checks				•	also after corrective maintenance
Surface Probe Leakage Current Checks				•	also after corrective maintenance
Endocavity Probe Leakage Current Checks				•	also after corrective maintenance
Transesophageal Probe Leakage Current Checks				•	also after corrective maintenance
Surgical Probe Leakage Current Checks				•	also after corrective maintenance
Measurement Accuracy Checks				•	also after corrective maintenance
Functional Checks				•	also after corrective maintenance

Section 10-4 Tools Required

10-4-1 Standard GE Tool Kit

The following is a description of the "Standard" GE tool kit in the USA. Not all tools are required for PMs.

Table 10-3 Overview of GE-1 Tool Kit Contents

Tool ID	Description	Tool ID	Description
9-45358	Pliers Retaining Ring	9-XL9971MM	Xcelite-hex Blade 1.27mm
9-4078	Scribe	9-XL9972MM	Xcelite-hex Blade 1.5mm
9-44572	Wrench Open End 3/8 - 7/16	9-XL9973MM	Xcelite-hex Blade 2 mm
9-44579	Wrench Open End 1/2 - 9/16	9-XL9974MM	Xcelite-hex Blade 2.5mm
9-44579	Wrench Open End 1/2 - 9/16	9-XL9975MM	Xcelite-hex Blade 3mm
9-45385	Pliers, Arc Joint 7 inch	9-XL9976MM	Xcelite-hex Blade 4mm
9-45378	Pliers, Slip Joint	9-XL9977MM	Xcelite-hex Blade 5mm
9-4518	Pliers, Long Nose, Miniature	9-XL991CM	Handle
9-4518	Pliers, Long Nose, Miniature	C2356E	Screw starter - Kedman Quick Wedge
9-44776	Ignition Wrench Set, 10 pc.	BLBO	Box - 18 Compartment
9-44601	Wrench, Adj., 4 inch	DWL4283T	Box - 5 Compartment
9-4151	Screwdriver, Blade, Stubby	9-41322	Pickup Tool, Claw type
9-41421	Screwdriver, Blade, Pocket clip	9-6757	6 pc Needle File Set
9-41594	Screwdriver, Blade 1/8 in. x 4 in.	9-9487	Utility Knife
9-41581	Screwdriver, Blade 3/16 in. x 4 in.	9-45341	Pliers Vice Grip 10 inch
9-39451	20' Steel Tape, locking Spring load	9-3001	Xacto Pen Knife
9-GH807	Ratchet, Offset, Slotted	9-HT62002	Solder Aid, Fork and Hook
68-412	Ratchet, Offset, Phillips	9-4099	Mirror, Round, Telescoping
9-GH130	Tapered Reamer	9-GH3001	Steel Rule Decimal 6 inch
9-41584	Screwdriver, slotted 1/4 in.X 6 in.	9-GH300ME	Steel Rule Metric 6 inch
9-4118	Screwdriver, Phillips #2, Stubby	9-XL9920	Xcelite-hex Blade.050 inch
9-41293	Screwdriver, Phillips #0	9-XL9921	Xcelite-hex Blade 1/16 inch
9-41294	Screwdriver, Phillips #1	9-XL9922	Xcelite-hex Blade 5/16 inch
9-41295	Screwdriver, Phillips #2	9-XL9923	Xcelite-hex Blade 3/32 inch
9-46677	Hex Keys, 20 pc., Metric	9-XL9924	Xcelite-hex Blade 1/8 inch
9-34701	1/4 in. Standard.Socket set (19 pc)	9-XL9925	Xcelite-hex Blade 5/32 inch
9-43499	1/2 inch Socket 1/4 inch drive	9-XL9926	Xcelite-hex Blade 3/16 inch
9-4355	Flex Spinner	9-XL99764	Xcelite-hex Blade 7/64
9-43523	Breaker	9-XL99964	Xcelite-hex Blade 9/64
9-43531	6 inch Ext.	9-XLM60	Mini-screwdriver kit

Table 10-3 Overview of GE-1 Tool Kit Contents (Continued)

Tool ID	Description	Tool ID	Description
9-65283	Case 8.5 in. x 4.5 in. x 2 in. Deep	9-45072	Pliers 6 inch Diagonal
9-46696	Hex Keys	9-XL100X	Wire Stripper/Cutter 5 inch - 100X
9-39829	Torpedo Level, Magnetic	9-XL87CG	Pliers - very fine needle nose-87CG
9-38461	Hammer, Ball Peen, 4 oz	9-WEWDT-07	Weller-Soldering-Replacement Tip(1)
9-4280	Universal Joint 1/4 inch	9-WS175-E	Wiss - Surgical Scissors
9-WEW60P3	Weller - Soldering Iron, 3 wire	KH174	Hemostat 5 inch Straight
9-WECT5B6	Weller - Soldering Iron Tip	KH175	Hemostat 5 inch curved
9-WEWDP12	Weller - Desoldering Pump	9-Z9480121	Alignment tool (red)
93383	Flashlight Mini-Mag Lite (AAA Bat.)		
9-GH408	Tweezers		
21576	Brush - Bristle		
9-4516	Pliers 4 1/4 inch Diagonal		

Table 10-4 Overview of GE-2 Tool Kit Contents(Continued)

GE-2 Sears Kit (#99034)			
Tool ID	Description	Tool ID	Description
9-45381	Pliers, Arc Joint 9 1/2 inch	9-44067	Socket 1 1/16 in. for 1/2 in. drive
9-45092	Pliers, Linesman 8 1/2 inch	9-42679	Socket 10MM Hex for 1/2 in. drive (2273333)
9-42882	Punch, Pin 3/32 inch	9-44262	Extension 10 inch for 1/2 in. drive (2273405)
9-42884	Punch, Pin 5/32 inch	9-4258	3/8 inch to 1/2 inch Adapter
9-42886	Punch, Pin 1/4 inch	9-34374	3/8 inch Metric Socket Set - 12 PT
9-42973	Cold Chisel 1/2 inch	9-44311	16mm Socket 12 pt.
9-GH77	Center Punch Automatic	9-33485	Metal Socket Tray
9-GH890	File Handle, Adj.	9-33484	Metal Socket Tray
9-31276	File, Round, Bastard 8 inch	9-33484	Metal Socket Tray
9-31277	File, Half Round, Bastard 8 inch	9-52068	Tap and Drill Set
9-31263	File, Flat Mill 8 inch	9-52722	#6 Tap
21045C	Close Quarter Saw	9-52723	#8 Tap
9-44604	Wrench, Adj 10 inch		High Speed Drill Set
9-41587	Screwdriver 5/16 inch x 8 inch		#36 Drill
9-41586	Screwdriver, Stubby 5/16 inch		#29 Drill
9-GH19512	Countersink 1/2 inch	9-44046	3/8 inch Socket Set
9-44741	12 PC Combination Wrench Set		

10-4-2 Special Tools, Supplies and Equipment

10-4-2-1 Specific Requirements for Care & Maintenance

Table 10-5 Overview of Requirements for Care & Maintenance

Tool	Part Number	Comments
Digital Volt Meter (DVM)		
Electric Safety Analyzer DALE 600	46-285652G1	For 120V Unit
Electric Safety Analyzer DALE 600E	46-328406G2	For 220V Units
Leakage Current Ultrasound Kit	2113015	For 120V and 220V Units
Anti Static Kit	46-194427P231 46-194427P279 46-194427P369 46-194427P373 46-194427P370	Kit includes anti-static mat, wrist strap and cables for 200 to 240 V system 3M #2204 Large adjustable wrist strap 3M #2214 Small adjustable wrist strap 3M #3051 conductive ground cord
Anti Static Vacuum Cleaner	46-194427P278 46-194427P279	120V 230V
Air Filter		air intake
Safety Analyzer	46-285652G1	DALE 600 KIT (or equivalent) for electrical tests
SVHS VCR Cassette	E7010GG E7010GF	60 minute 120 minute
SVHS VCR Head Cleaner		See VCR user manual for requirements
3.5" MOD MEDIA	E8381AA E8381AB	blank 128 M disk blank 230 M disk
5.25" MOD Media		
3.5" MOD Media Cleaner	2117811	cleans the diskettes
5.25" MOD Media Cleaner		cleans the diskettes
3.5" MOD Head Cleaner Kit	2148392	cleans the drive heads
5.25" MOD Head Cleaner Kit		cleans the drive heads
QIQ Phantom	E8370RB	RMI Grayscale Target Model 403GS
CD-RW Media		For LOGIQ C Series
B/W Printer Cleaning Sheet		See printer user manual for requirements
Color Printer Cleaning Sheet		See printer user manual for requirements
Disposable Gloves		

10-4-3 Input Power

10-4-3-1 Mains Cable Inspection

Table 10-6 Mains Cable Inspection

Step	Item	Description
1	Unplug Cord	Disconnect the mains cable from the wall and system.
2	Inspect	Inspect it and its connectors for damage of any kind.
3	Verify	Verify that the LINE, NEUTRAL and GROUND wires are properly attached to the terminals, and that no strands may cause a short circuit.
4	Verify	Inlet connector retainer is functional.

10-4-4 Cleaning

10-4-4-1 General Cleaning

Table 10-7 General Cleaning

Step	Item	Description
1	Console	Use a fluid detergent in warm water on a soft, damp cloth to carefully wipe the entire system. Be careful not to get the cloth too wet so that moisture does not enter the console.
2	Probe Holder	Clean probe holders (they may need to be soaked to remove excess gel).

NOTE: For your convenience or if the air filter is too dirty, replacement filters are available. refer to Chapter 9 for the air filter replacement part number.

10-4-5 Physical Inspection

Table 10-8 Physical Checks

Step	Item	Description
1	Labeling	Verify that all system labeling is present and in readable condition. refer to the LOGIQ C Series User Manual for details.
2	Scratches & Dents	Inspect the console for dents, scratches or cracks.
3	Wheels & Brakes	Check all wheels and casters for wear and verify operation of foot brake, to stop the unit from moving, and release mechanism. Check all caster locks and caster swivel locks for proper operation.
4	Cables & Connectors	Check all internal cable harnesses and connectors for wear and secure connector seating. Pay special attention to footswitch assembly and probe strain or bend reliefs.
5	Shielding & Covers	Check to ensure that all EMI shielding, internal covers, air flow panels and screws are in place. Missing covers and hardware could cause EMI/RFI problems while scanning.
6	External I/O	Check all connectors for damage and verify that the labeling is good.
7	Op Panel Lights	Check for proper operation of all operator panel and TGC lights.
8	Monitor Light	Check for proper operation of any monitor lights if available.
9	External Microphone	Check for proper operation of any external microphones by recording an audio test.

10-4-6 Outlet Test - Wiring Arrangement - USA & Canada

Test all outlets in the area for proper grounding and wiring arrangement by plugging in the neon outlet tester and noting the combination of lights that are illuminated. Any problems found should be reported to the hospital immediately and the receptacle should not be used.

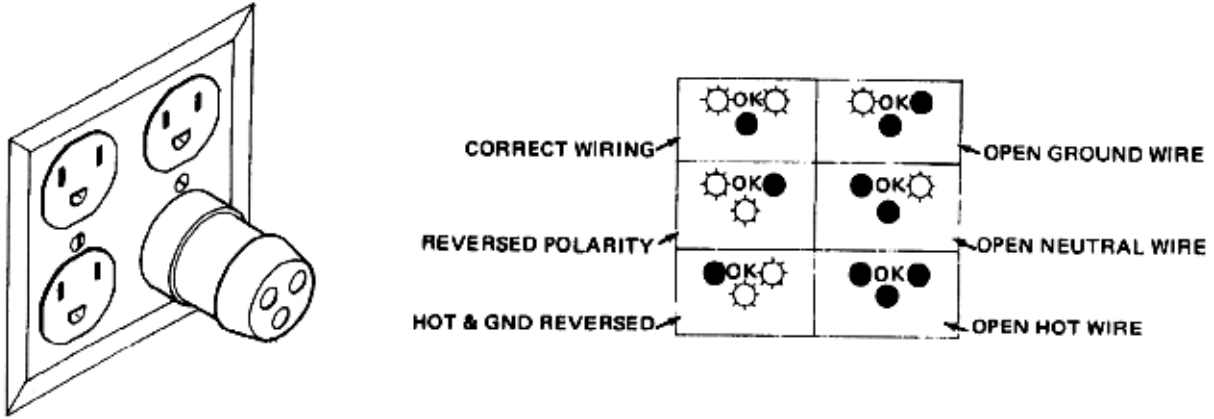

Figure 10-1 Typical Outlet Tester

The Dale 600 has self-contained lamps designed for testing the outlet wiring arrangement. Plug the Dale 600 into each outlet to be tested comparing the lamp status.

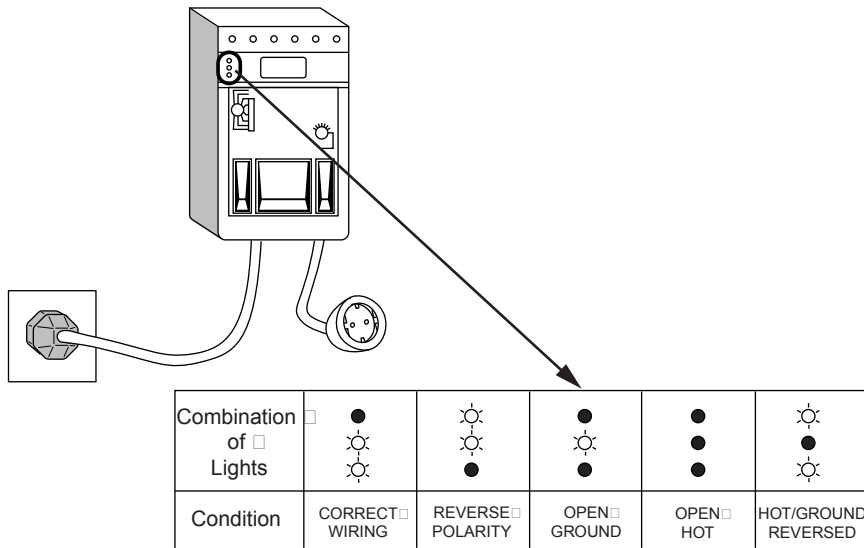

Figure 10-2 Dale 600 Outlet Test

NOTE: No outlet tester can detect the condition where the Neutral (grounded supply) conductor and the Grounding (protective earth) conductor are reversed. If later tests indicate high leakage currents, this should be suspected as a possible cause and the outlet wiring should be visually inspected.

10-4-7 Grounding Continuity



CAUTION Electric Shock Hazard. The patient must not be contacted to the equipment during this test

Measure the resistance from the third pin of the attachment plug to the exposed metal parts of the case. The ground wire resistance should be less than **0.2 ohms**. reference the procedure in the IEC 601-1.1.

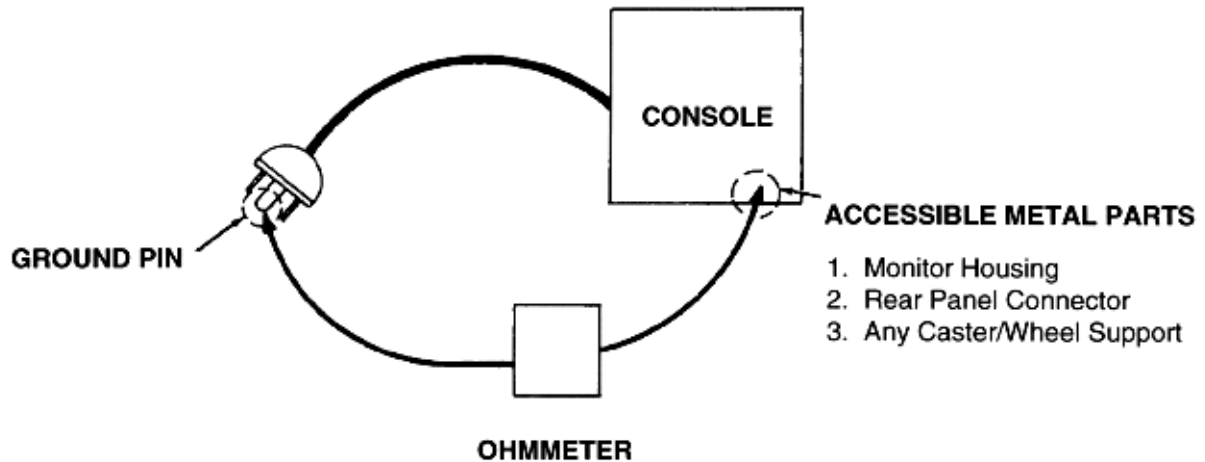

Figure 10-3 Ground Continuity Test

10-4-7-1 Meter Procedure

Follow these steps to test the ground wire resistance.

- 1.) Turn the LOGIQ C Series unit OFF.
- 2.) Plug the unit into the meter, and the meter into the tested AC wall outlet.
- 3.) Plug the black chassis cable into the meter's "CHASSIS" connector and attach the black chassis cable clamp to an exposed metal part of the LOGIQ C Series unit.
- 4.) Set the meter's "FUNCTION" switch to the RESISTANCE position.
- 5.) Set the meter's "POLARITY" switch to the OFF (center) position.
- 6.) Measure and record the ground wire resistance.

10-4-7-2 Dale 600 - Ground Continuity

The Dale 600 measures line cord resistance from the third pin of the attachment plug to the meter's Chassis Cable clamp. Test the grounding continuity of the system to all exposed metal parts in accordance with the IEC 601-1.1 procedure as above. refer to the Dale 600 Instruction Manual for meter self tests and operation. Record measured resistance of the grounding continuity. The ground wire resistance should be less than 0.2 (Use any safety analyzer.)

10-4-8 Chassis Leakage Current Test

10-4-8-1 Definition

This test measures the current that would flow in a grounded person who touched accessible metal parts of the bedside station if the ground wire should break. The test verifies the isolation of the power line from the chassis. The meter is connected from accessible metal parts of the case to ground. Measurements should be made with the unit On and Off, with the power line polarity Normal and Reversed. Record the highest reading.



CAUTION Electric Shock Hazard. When the meter's ground switch is OPEN, don't touch the unit!



CAUTION Equipment damage possibility. Never switch the Polarity and the status of Neutral when the unit is powered ON. Be sure to turn the unit power OFF before switching them using the POLARITY switch and/or the NEUTRAL switch. Otherwise, the unit may be damaged.

10-4-8-2 Generic Procedure

The test verifies the isolation of the power line from the chassis. The testing meter is connected from accessible metal parts of the case to ground. Measurements should be made with the unit ON and OFF, with the power line polarity Normal and Reversed. Record the highest reading of current.

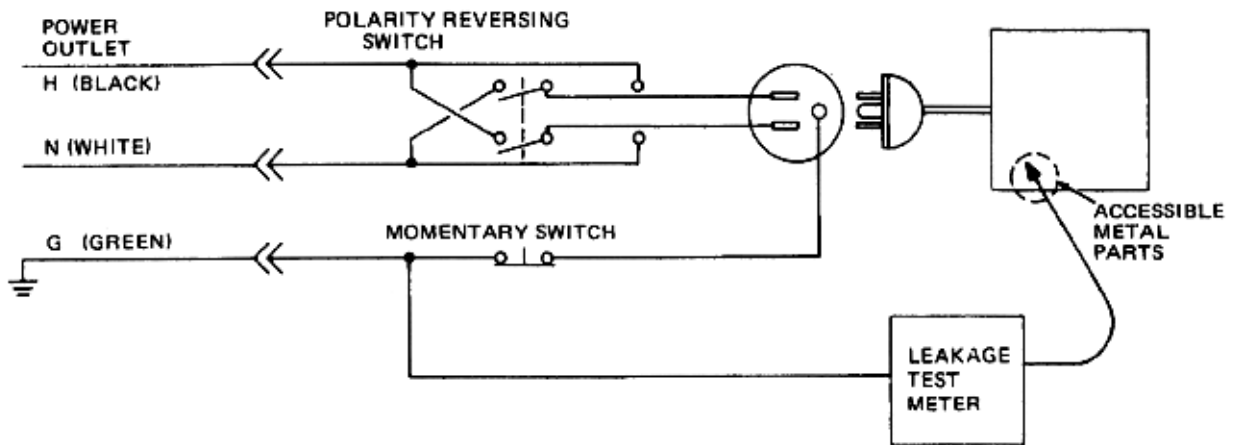

Figure 10-4 Set Up for Chassis Source Leakage Current, IEC 601-1 Clause 19 - Continuous Leakage Currents and Patient, Auxiliary Currents

When using the Microguard or a similar test instrument, its power plug may be inserted into the wall outlet and the equipment under test is plugged into the receptacle on the panel of the meter. This places the meter in the grounding conductor and the current flowing from the case to ground will be indicated in any of the current ranges. The maximum allowable limit for chassis source leakage is shown in [Table 10-14](#).

10-4-8-3 Dale 600 Meter Procedure

When measuring system chassis currents with the Dale 600, always use the CHASSIS selection of the external/chassis function switch. This requires the ground clip lead and changing the meters switches in accordance with the IEC 601-1.1. refer to the Dale 600 Instruction Manual for meter self-test and operation. Record the highest leakage current measured.

Follow these steps to test the unit for leakage current.

- 1.) Turn the LOGIQ C Series unit OFF.
- 2.) Plug the unit into the meter, and the meter into the tested AC wall outlet
- 3.) Plug the black chassis cable into the meter's "CHASSIS" connector and attach the black chassis cable clamp to an exposed metal part of the LOGIQ C Series.
- 4.) Set the tester's "FUNCTION" switch to CHASSIS position.
- 5.) Follow the test conditions described for respective test points shown in [Table 10-9](#).

Table 10-9 Chassis Leakage Current Test Condition

TEST	CONDITION
1	Mounting screw for probe receptacle
2	caster support
3	Mounting screw for CRT housing
4	Mounting screw for peripheral plugged into unit
5	Mounting screw for other peripheral powered by unit

- 6.) Keep a record of the results with other hard copies of PM data kept on site.

10-4-8-4 Dale 600 Meter Procedure

The Dale 600 provides five snap type ECG buttons for testing patient leads. Snap on all patient leads to the meter and assure that the ground clip is connected to the system's ground terminal. Select the meter's LEAD-GND function. Select and test each ECG lead positions (except "ALL") of the LEAD selector, testing each to the power condition combinations found in "PATIENT LEAD LEAKAGE" table in the "PM CHECKLIST". Record the highest leakage current measured for each Power selection.

 **CAUTION** Line voltage is applied to the ECG leads during this test. To avoid possible electric shock hazard, the system being tested must not be touched by patients, users or anyone while the ISO TEST switch is depressed. When the meter's ground switch is OPEN, don't touch the unit!

Follow these steps to test the ECG module for leakage current.

- 1.) Turn the LOGIQ C Series unit OFF.
- 2.) Plug the unit into the meter, and the meter into the tested AC wall outlet.
- 3.) Plug the black chassis cable into the meter's "CHASSIS" connector and attach the black chassis cable clamp to an exposed metal part of the LOGIQ C Series unit.
- 4.) Connect the patient leads to the corresponding snaps located at the upper front of the Dale 600/600E. Lead nomenclature for this test is not important.

10-4-8-4 Dale 600 Meter Procedure (cont'd)

- 5.) Set the meter's "FUNCTION" switch to LEAD TO GROUND position to measure the patient lead to ground leakage current.
- 6.) Select and test each ECG lead positions (except ALL) of the LEAD selector, testing each to the power condition combinations.

Table 10-10 Testing Power Conditions

ECG Power	Meter's Polarity Switch	Meter's Neutral Switch
ON	NORM	CLOSED
ON	NORM	OPEN
ON	REVERSE	CLOSED
ON	REVERSE	OPEN
OFF	NORM	CLOSED
OFF	NORM	OPEN
OFF	REVERSE	CLOSED
OFF	REVERSE	OPEN

10-4-8-4 Dale 600 Meter Procedure (cont'd)

- 7.) Record the patient lead to ground leakage current measured on the data sheet.
- 8.) Set the meter's "FUNCTION" switch to LEAD TO LEAD position to measure the lead to lead leakage current.
- 9.) Select and test each ECG lead positions (except ALL) of the LEAD selector, testing each to the power condition combinations.
- 10.) Record the lead to lead leakage current measured on the data sheet.
- 11.) Set the meter's "FUNCTION" switch to LEAD ISO position to measure the patient lead isolation current.
- 12.) Select and test each ECG lead positions (except ALL) of the LEAD selector, testing each to the power condition combinations.
- 13.) Depress the rocker switch to ISO TEST and read the isolation current. To apply the voltage to the lead safely, the voltage is only applied when the rocker switch is depressed to ISO TEST.
- 14.) Record the patient lead isolation current measured on the data sheet.

10-4-9 Isolated Patient Lead (Source) Leakage—Lead to Lead

reference the procedure in the IEC 60601-1. When using the Dale 600, switch the meter's function selector to the LEAD-LEAD position. Select and test each of the five ECG lead positions (except ALL) on the LEAD selector, testing each to the power condition combinations found in the table. Record the highest leakage current measured.

10-4-9-1 Dale 600 Patient Lead Tests**NEUTRAL POLARITY**

- 1.) Closed Normal
- 2.) Open Normal
- 3.) Closed Reversed
- 4.) Open Reversed

10-4-10 Isolated Patient Lead (Sink) Leakage-Isolation Test

reference the procedure in the IEC 60601-1. When using the Dale 600, switch the meter's function selector to the LEAD-ISO. Select the ALL position on the lead selector. Depress the rocker switch to ISO TEST to test lead isolation.

 **CAUTION** Line voltage is applied to the ECG leads during this test. To avoid possible electric shock hazard, the system being tested must not be touched by patients, users or anyone while the ISO TEST switch is depressed.

NOTE: *It is not necessary to test each lead individually or power condition combinations as required in previous tests.*

10-4-10-1 Data Sheet for ECG Leakage Current

The test passes when all readings measure less than the value shown in the table below. Record all data on the PM Inspection Certificate.

Table 10-11 Maximum Allowance Limit for ECG Leakage Current

	AC Power Source	Maximum Allowance Limit	
		GROUND OPEN	GROUND CLOSED
Patient Lead to Ground Leakage Current Test and Patient Lead to Lead Leakage Current Test	115V	10uA	10uA
	220/240V	500uA	10uA

Table 10-12 Maximum Allowance Limit for ECG Leakage Current

	AC Power Source	Maximum Allowance Limit
Patient Lead Isolation Current Test	115V	20uA
	220/240V	5mA

Table 10-13 Typical Data Sheet for ECG Leakage Current

ECG Power	Tester Polarity Switch	Tester Ground Switch	Tester Lead Selector				
			RL	RA	LA	LL	C
ON	NORM	CLOSED					
ON	REVERSE	CLOSED					
ON	NORM	OPEN					
ON	REVERSE	OPEN					
OFF	NORM	CLOSED					
OFF	REVERSE	CLOSED					
OFF	NORM	OPEN					
OFF	REVERSE	OPEN					

10-4-11 Probe Leakage Current Test

10-4-11-1 Definition

This test measures the current that would flow to ground from any of the probes through a patient who is being scanned and becomes grounded by touching some other grounded surface.

10-4-11-2 Generic Procedure

Measurements should be made with the ground open and closed, with power line polarity normal and reversed, and with the unit Off and On. For each combination, the probe must be active to find the worst case condition.

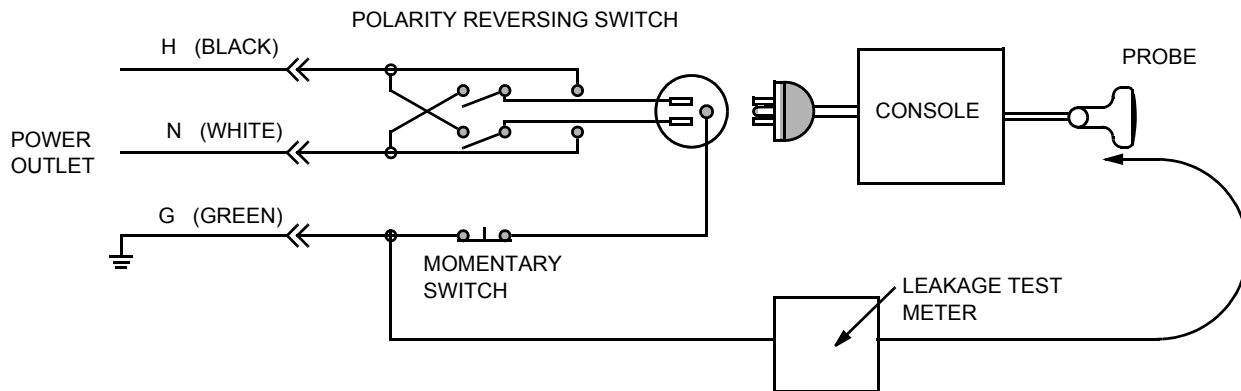

Figure 10-5 Set Up for Probe Leakage Current

NOTE: Each probe will have some amount of leakage current, dependent on its design. Small variations in probe leakage currents are normal from probe to probe. Other variations will result from differences in line voltage and test lead placement.

10-4-11-3 Meter Procedure Using Probe Adapter

The Dale 600/600E provides a method for testing probes independently from the system. The meter utilizes a probe adapter to apply a test potential commonly to all connector pins.

The probe's imaging area is immersed in a saline solution along with a grounding probe from the meter to complete the current path. Saline solution is a mixture of water and salt. The salt adds a free ion to the water, making it conductive. Normal saline solution is 0.9% salt or 1/2 gram salt per 1 liter of water. If saline is not available, a mixture of 1 quart water with one or more grams of table salt, mixed thoroughly, will substitute.

CAUTION To avoid probe damage and possible electric shock, do not immerse probes into any liquid beyond the level indicated in the probe users manual. **Do not touch the probe, conductive liquid or any part of the unit under test while the ISO TEST switch is depressed.**

Follow these steps to test each transducer for leakage current.

- 1.) Turn the LOGIQ C Series unit OFF.
- 2.) Plug the unit into the test meter, and the meter into the tested AC wall outlet.
- 3.) Connect the probe for test with the meter's appropriate adapter.
- 4.) Plug the saline probe into the meter's "CHASSIS" connector.
- 5.) Plug the probe adapter into the meter's connector marked "EXTERNAL".

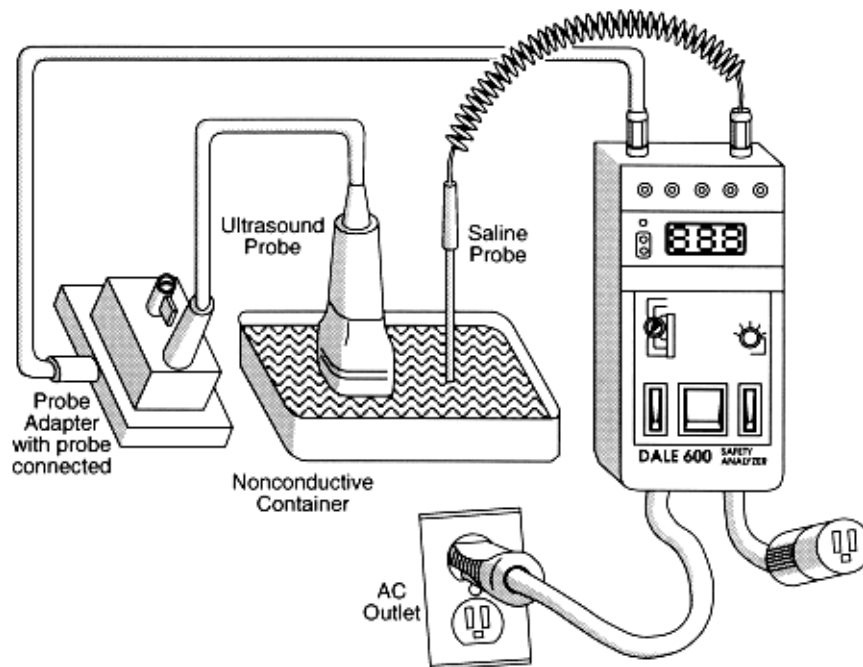

Figure 10-6 Transducer Source Leakage Current Test

- 6.) Set the meter's "FUNCTION" switch to EXTERNAL position.
- 7.) Add the saline probe and the imaging area of the probe into the saline bath.
- 8.) Have unit power ON for the first part; turn it OFF for the second half.
- 9.) Depress the ISO TEST rocker switch and record the highest current reading.
- 10.) Follow the test conditions described in [Table 10-14](#) for every transducer.
- 11.) Keep a record of the results with other hand copies of PM data.

10-4-11-4 No Meter Probe Adapter Procedure

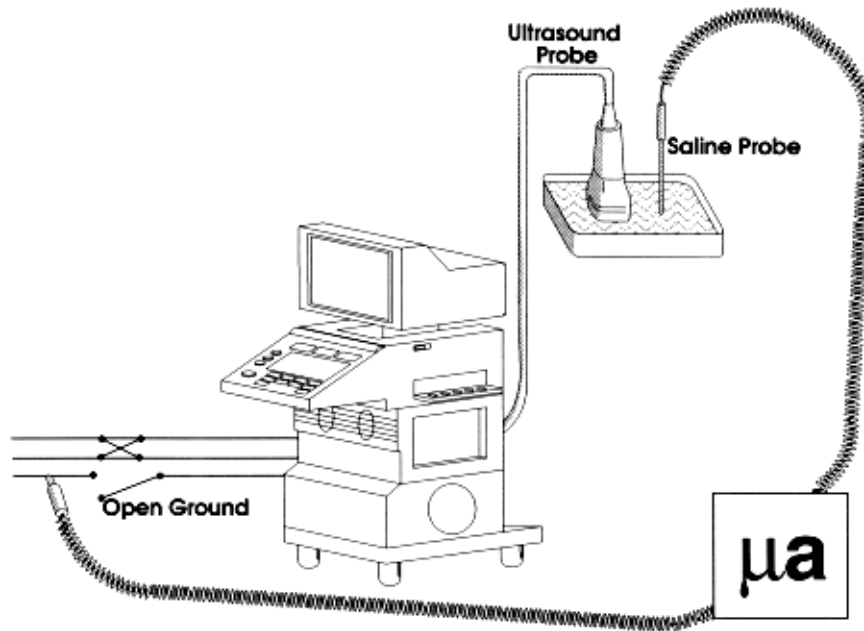

Figure 10-7 Check Without Probe Adapter

Follow these steps to test each transducer for leakage current.

- 1.) Turn the LOGIQ C Series unit OFF.
- 2.) Plug the unit into the test meter, and the meter into the tested AC wall outlet.
- 3.) Plug the external probe into the meter's (Dale 600) "EXTERNAL" connector.
- 4.) Set the meter's "FUNCTION" switch to EXTERNAL position.
- 5.) Connect the probe for test with the connector of the console.
- 6.) Add the saline probe and the imaging area of the probe into the saline bath.
- 7.) Have unit power ON for the first part; turn it OFF for the second half.
- 8.) Depress the ISO TEST rocker switch and record the highest current reading.
- 9.) Follow the test conditions described in [Table 10-14](#) for every transducer.
- 10.) Keep a record of the results with other hand copies of PM data.

10-4-11-5 Data Sheet for Transducer Source Leakage Current

The test passes when all readings measure less than the values. Record all data on the PM Inspection Certificate.



CAUTION Equipment damage possibility. Never switch the Polarity and the status of Neutral when the unit is powered ON. Be sure to turn the unit power OFF before switching them using the POLARITY switch and/or the NEUTRAL switch. Otherwise, the unit may be damaged

Table 10-14 Typical Data Sheet For Transducer Source Leakage Current

Transducer Tested:			
Unit Power	Tester Power Polarity Switch	Tester GROUND or NEUTRAL Switch	Measurement
ON	NORM	OPEN	
ON	NORM	CLOSED	
ON	REV	OPEN	
ON	REV	CLOSED	
OFF	NORM	OPEN	
OFF	NORM	CLOSED	
OFF	REV	OPEN	
OFF	REV	CLOSED	

Section 10-5 When There's Too Much Leakage Current...

CHASSIS FAILS

Check the ground on the power cord and plug for continuity. Ensure the ground is not broken, frayed, or intermittent. Replace any defective part.

Tighten all grounds. Ensure star washers are under all ground studs.

Inspect wiring for bad crimps, poor connections, or damage.

Test the wall outlet; verify it is grounded and is free of other wiring abnormalities. Notify the user or owner to correct any deviations. As a work around, check the other outlets to see if they could be used instead.

NOTE: *No outlet tester can detect the condition where the white neutral wire and the green grounding wire are reversed. If later tests indicate high leakage currents, this should be suspected as a possible cause and the outlet wiring should be visually inspected.*

PROBE FAILS

Test the probe in another connector to isolate if the fault lies with the probe or the scanner.

NOTE: *Each probe will have some amount of leakage, dependent on its design. Small variations in probe leakage currents are normal from probe to probe. Other variations will result from differences in line voltage and test lead placement. The maximum allowable leakage current for body surface contact probe differs from inter-cavity probe. Be sure to enter the correct probe type in the appropriate space on the check list.*

If excessive leakage current is slot dependent, inspect the system connector for bent pins, poor connections, and ground continuity.

If the problem remains with the probe, replace the probe.

PERIPHERAL FAILS

Tighten all grounds. Ensure star washers are under all ground studs.

Inspect wiring for bad crimps, poor connections, or damage.

STILL FAILS

If all else fails, begin isolation by removing the probes, external peripherals, then the on board ones, one at a time while monitoring the leakage current measurement.

NEW UNIT

If the leakage current measurement tests fail on a new unit and if situation can not be corrected, submit a Safety Failure Report to document the system problem. Remove unit from operation.

ECG FAILS

Inspect cables for damage or poor connections.

ULTRASOUND INSPECTION CERTIFICATE

Customer Name:		System ID:	Dispatch Number / Date Performed:	Warranty/Contract/HBS
System Type		Model Number:	Serial Number:	Manufacture Date:
Probe 1:	Frequency:	Scan Format*:	Model Number:	Serial Number:
Probe 2:	Frequency:	Scan Format*:	Model Number:	Serial Number:
Probe 3:	Frequency:	Scan Format*:	Model Number:	Serial Number:
Probe 4:	Frequency:	Scan Format*:	Model Number:	Serial Number:
Probe 5:	Frequency:	Scan Format*:	Model Number:	Serial Number:
Probe 6:	Frequency:	Scan Format*:	Model Number:	Serial Number:
Probe 7:	Frequency:	Scan Format*:	Model Number:	Serial Number:
Probe 8:	Frequency:	Scan Format*:	Model Number:	Serial Number:
Probe 9:	Frequency:	Scan Format*:	Model Number:	Serial Number:

* Scan Format: Phased Array, Linear Array, Curved Array, Mechanical Array or Other

FUNCTIONAL CHECKS

PHYSICAL INSPECTION AND CLEANING

Functional Check (if applicable)	OK? or N/A	Physical Inspection and Cleaning (if applicable)	Inspect	Clean
B-Mode Function		Console		
Doppler Modes Function		Monitor		
CF-Mode Function		Touch Panel		
M-Mode Function		Air Filter		
Applicable Software Options		Probe Holders		
Applicable Hardware Options		External I/O		
Control Panel		Wheels, Brakes & Swivel Locks		
Monitor		Cables and Connectors		
Touch Panel		GE Approved Peripherals (VCR, CD-RW, MOD, Printers)		
Measurement Accuracy				
GE Approved Peripherals				

COMMENTS:

ELECTRICAL SAFETY

Electrical Test Performed	Max Value Allowed	Value Measured	OK?	Comments
Outlet (correct ground & wiring config.)				
System Ground Continuity				
Chassis Source Leakage Current - Probe				
Chassis Source Leakage Current - Caster				
Chassis Source Leakage Current - CRT				
Patient Lead Source Leakage (Lead to Ground)				
Patient Lead Source Leakage (Lead to Lead)				
Patient Lead Source Leakage (Isolation)				
Peripheral 1 Leakage Current				
Peripheral 1 Ground Continuity				
Peripheral 2 Leakage Current				
Peripheral 2 Ground Continuity				
Peripheral 3 Leakage Current				
Peripheral 3 Ground Continuity				

PROBES

Probe Number (from previous page)	Max Value Allowed	Max Value Measured	OK?	Comments
Probe 1:				
Probe 2:				
Probe 3:				
Probe 4:				
Probe 5:				
Probe 6:				
Probe 7:				
Probe 8:				
Probe 9:				

Final Check. All system covers are in place. System scans with all probes as expected.

Accepted by: _____

INDEX

A,B

Abbreviations, 9-1
Archiving Images
 Move, 4-29
Backup
 Patient Database, 4-26
 Preset Configurations, 4-26
Basic Measurements
 Functional Checks, 4-23
Body pattern
 display location, 4-8
Boot Up, 3-8

C

Caps lock
 display location, 4-8
CE Compliance, 1-9
Cine gauge
 display location, 4-8
Color Mode
 Overview, 4-15
Connectivity
 Worksheet, 3-19
Contact Information, 1-10
Control Panel, 4-6
Customer Assistance, 1-10

D

Dangerous Procedure Warnings, 1-8
Date/Time
 display location, 4-8
Depth scale
 display location, 4-8
DICOM Network Function, 2-9

E

Electrical Safety, 1-7
Electrostatic Discharge Warning, 1-9
EMI, 1-9
ESD, 1-9
Exam study
 display location, 4-8

F

Focal zone
 display location, 4-8

Functional Checks, 4-1
 Basic Measurements, 4-23
 Control Panel, 4-6
 Image Management, 4-25
 Monitor Display, 4-8
 Peripherals, 4-35
 Probes/Connector Usage, 4-24

G

Gathering Trouble Data, 7-2
General Cleaning, 10-7
Gray/color bar
 display location, 4-8

H

Hazard Icons, 1-5
Hospital name
 display location, 4-8
Human Safety, 1-6

I

Image Management
 Functional Checks, 4-25
Image preview
 display location, 4-8
Imaging parameters
 display location, 4-8
Institution name
 display location, 4-8

M

Measurement summary window
 display location, 4-8
Mechanical Safety, 1-6
Media
 Formatting, 4-26
Monitor Display
 Functional Checks, 4-8
Monitor display
 location, 4-8
Move
 Archiving Images, 4-29

O

Operator identification
display location, 4-8

Vital System Information, 7-2

P

P4 Key Function, 7-4, , 7-6
Patient identification
display location, 4-8
Patient name
display location, 4-8
PC Diagnostics, 7-10
Hard Drive Tests, 7-10
Keyboard Test, 7-11
Memory Tests, 7-10
PC Diagnostics (Interactive Tests), 7-11
Peripherals
Functional Checks, 4-35
Power On, 3-8
Power-up Procedures
Voltage Settings, 3-7
Probe identifier
display location, 4-8
Probe orientation marker
display location, 4-8
Probes/Connector Usage
Functional Checks, 4-24
Product Icons, 1-5

R

Required Features, 2-7
Restore
Patient Database, 4-28
Preset Configurations, 4-28

S

Safety Considerations, 1-6
Screen Captures, 7-6
Service Manual
Purpose of, 1-1
System Manufacturer, 1-11

T

TGC
display location, 4-8
Touch Panel
Functional Checks, 4-6
Trouble Image with Logs, 7-3
Troubleshooting
Gathering Trouble Data, 7-2
Screen Captures, 7-6
Trouble Image with Logs, 7-3

U

Ultrasound Room Layout, 2-8

V

Voltage Settings, 3-7

W

Warnings and Cautions, 1-6

© 2008 - 2010, General Electric Company.
GE Healthcare-GE Medical Systems Ultrasound.
9900 Innovation Drive
Wauwatosa, Wisconsin 53226
USA

