

ERBE

ICC 200
ICC 300 H-E
ICC 350

09.2004

Service manual

ICC 200, ICC 300 H-E, ICC 350

SERVICE MANUAL

10128-002, 10128-009, 10128-010, 10128-015, 10128-016
10128-023, 10128-025, 10128-027, 10128-028, 10128-036
10128-051, 10128-054, 10128-055, 10128-056, 10128-058
10128-061, 10128-064, 10128-065, 10128-066, 10128-070
10128-071, 10128-072, 10128-073, 10128-074, 10128-075
10128-076, 10128-077, 10128-078, 10128-080, 10128-081
10128-082, 10128-083, 10128-200, 10128-202, 10128-204
10128-205, 10128-206, 10128-213, 10128-214, 10128-300
10128-301, 10128-303, 10128-304, 10128-305, 10128-306
10128-307, 10128-310, 10128-403

09.2004

This service manual was created by

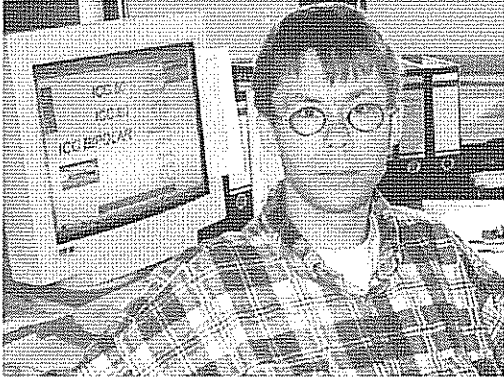

Michael Grosse

Dipl.-Phys. (Physicist)

Tel (+49) 70 71 / 755-254

Fax (+49) 70 71 / 755-5254

E-Mail mgrosse@erbe-med.de

Net <http://www.erbe-med.de>

Please contact me directly with your suggestions, criticism or information regarding this manual. Your feedback helps me design this document according to your requirements and to constantly improve it.

All rights to this service manual, particularly the right to reproduction, distribution and translation, are reserved. No part of this service manual may be reproduced in any form (including photocopying, microfilm or other means), or processed, reproduced or distributed by means of electronic systems without prior written permission from ERBE Elektromedizin GmbH.

The information contained in this service manual may be revised or extended without prior notice and represents no obligation on the part of ERBE Elektromedizin GmbH.

Copyright © ERBE Elektromedizin GmbH, Tübingen 2004

Printed by: ERBE Elektromedizin GmbH, Tübingen

Art. No.: 80116-201

Printed in Germany

Contents

Chapter	Title	Page
0	Table of contents	5
1	Test programs and adjustments	7
	Calling up Test program mode	10
	Basic settings of the SETUP parameters	11
	Front panel of the ICC 200 (INT) after starting up the unit	12
	Front panel of the ICC 200 (UL) after starting up the unit	13
	Front panel of the ICC 300 after starting up the unit	15
	Front panel of the ICC 350 after starting up the unit	16
	Test programs 1–8	17
	Test program 9 (Display programs 1–12)	28
	Test programs 10–15	39
	Test program 16 (Adjustments, measuring equipment, jumper)	45
	Adjustment of ZMK Neurotest and TUR Neurotest	105
	Adjustment of remote control for Neurotest	111
	Adjustment of activation and instrument detection	115
	Test program 17, 23	123
2	ERROR list	127
3	Circuit description	137
4	Block diagrams	169
5	Circuit diagrams	175
A	Appendix A (Part numbers, PCB arrangement)	241
B	Appendix B (Abbreviations, notes, addresses)	263

Chapter 1

Test programs and adjustments

Test programs

ERBOTOM ICC 350, 300, 200
Version 4.0 / 3.0 / 2.0

No.	Test program function	V 4.0 / 3.0 / V 2.0
1	Basic front panel setting (only ICC 300 and 200)	x
2	Calls up the Error list	x
3	Test of all D-flipflop circuit memories	x
4	Test of all front panel visual signals	x
5	Test of all acoustic signals	x
6	Test of all relays	x
7	NESSY: Version number setting	x
8	Display of software version no. and option no.	x
9	Activation of display programs	x
10	Time limit setup	x
11	Measurement and display of extra-low voltages +15 volts, -15 volts, +24 volts and the temperature	x
12	Setting the FORCED voltage (2.0: 3 x forced; 4.0: 4 x forced)	x
13	not assigned	
14	not assigned	
15	not assigned	
16	Test and setting help for all unit calibration functions	x
17	Brightness setting for the seven-segment displays	x
18	not assigned	
19	not assigned	
20	not assigned	
21	not assigned	
22	not assigned	
23	AUTO START start delay setup	x

Calling up the TEST PROGRAM mode

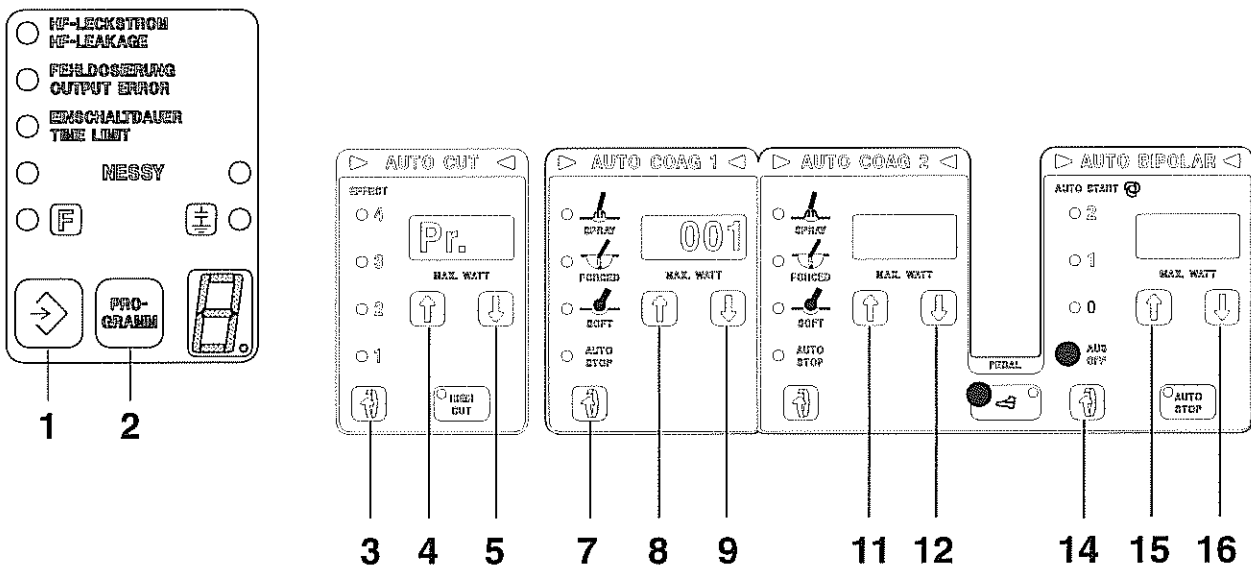

Note regarding the drawing

The front panel shown of the ICC 350 applies to the ICC 200 and ICC 300 in such a way that only the AUTO CUT and AUTO COAG control panels apply to the ICC 300, and the AUTO CUT, AUTO COAG and AUTO BIPOLAR control panels apply to the ICC 300.

Calling up

Press key 3 (Roll) when switching on the power and hold it down.

Setting the test program number

Using keys 8 (Up) or 9 (Down), set the required program number.

Starting and finishing test programs

By pressing key 3 (Roll), start or finish a test program.

Exiting the test program mode

Exit the TEST PROGRAM MODE by switching off the power or setting TEST PROGRAM no. 0 using key 9 (Down).

Basic settings of the SETUP parameters

ERBOTOM ICC 350, 300 and 200

AUTO START delay ICC 350, ICC 300	Autostart stage	Basic settings	Remarks
AUTO START delay ICC 200	0	0 s	adjustable using Test program 23
	1	0.5 s	
	2	1 s	
	no stepping	0.5 s	
Time limit setting ICC 350	output	max. time limit	Test program 10
	Auto Cut	90 s	
	Auto Coag 1	90 s	
	Auto Coag 2	90 s	
	Auto Bipolar	90 s	
NESSY version no.	NE 1	*)	adjustable using Test program 7
FORCED voltage version	1		adjustable using Test program 12
Brightness of the seven-segment display	10		adjustable using Test program 17

- *) || means a split NE electrode,
 | means a non-split NE electrode,
 || means both split and non-split NE electrode are possible.

Front panel of the ICC 200 (INT)

After starting up the unit

Factory setting

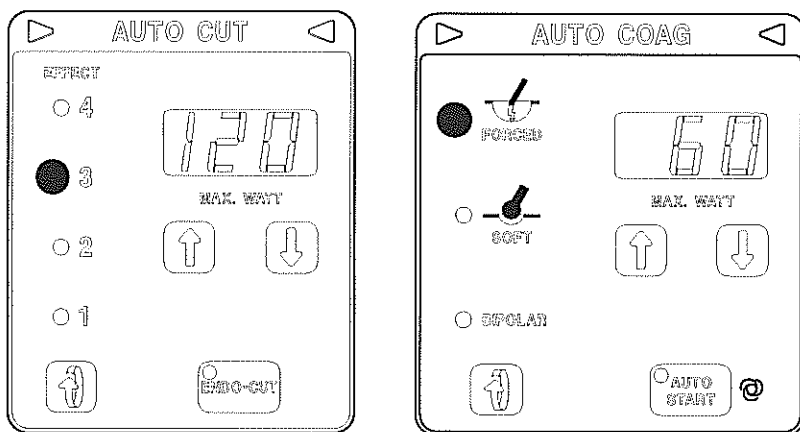

Basic setting ICC 200 without ENDO CUT option		
AUTO CUT	Effect 3	120 watts max.
AUTO COAG	FORCED	60 watts max.
AUTO COAG (with ARGON option)	Spray	60 watts max.
Footswitch setting	yellow = AUTO CUT	blue = AUTO COAG

Basic setting ICC 200 with ENDO CUT option		
AUTO CUT	Effect 3	120 watts max.
AUTO COAG	FORCED	60 watts max.
AUTO COAG (with ARGON option)	Spray	60 watts max.
Footswitch setting	yellow = AUTO CUT	blue = AUTO COAG
ENDO CUT	ON	
	Pulse length	$t_{ON} = 50 \text{ ms}$
	Pause length	$t_{OFF} = 750 \text{ ms}$

Front panel of the ICC 200 (UL)

After starting up the unit

Factory programming

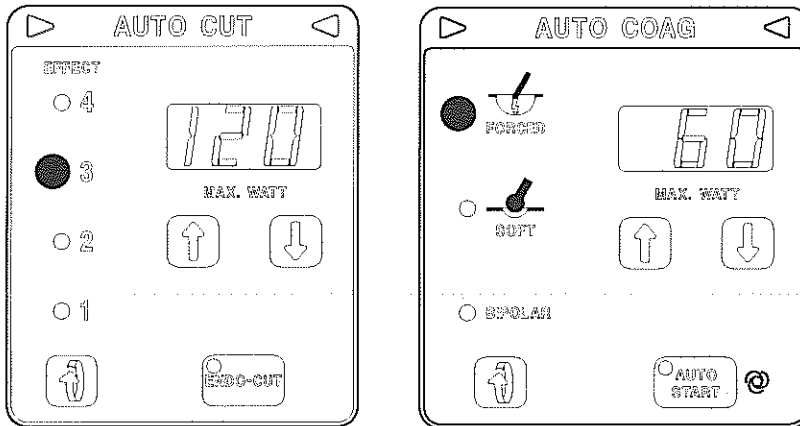

Basic programming ICC 200 without ENDO CUT option		
AUTO CUT	Effect 3	120 watts max.
AUTO COAG	FORCED	60 watts max.
Footswitch setting	yellow = AUTO CUT	blue = AUTO COAG

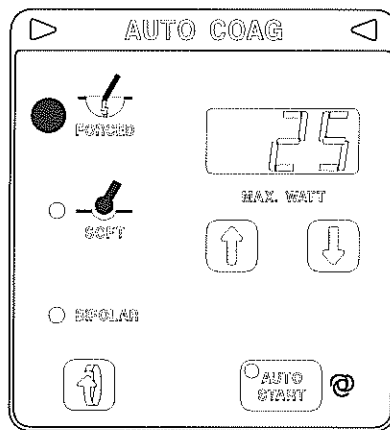
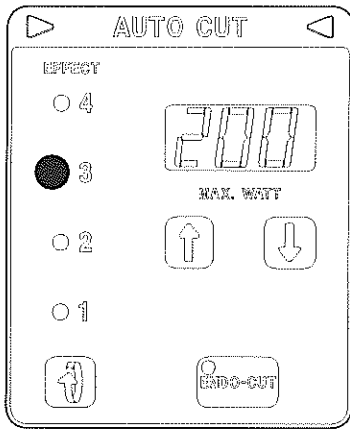

NOTE

If the settings are reset, the factory programming of the ICC 200 E and ICC 200 E/A units is lost. It can be restored using the following table.

Basic programming ICC 200 E and ICC 200 E/A		
AUTO CUT	Effect 3	200 watts max.
AUTO COAG	FORCED	25 watts max.
AUTO COAG	SOFT	65 watts max.
AUTO COAG	BIPOLAR	20 watts max.
AUTO COAG (for ICC 200 E/A only)	Spray	60 watts max.
Footswitch setting	yellow = AUTO CUT	blue = AUTO COAG
ENDO CUT	ON	
	Pulse length	$t_{ON} = 50 \text{ ms}$
	Pause length	$t_{OFF} = 750 \text{ ms}$

Front panel of the ICC 300

After starting up the unit

Factory setting

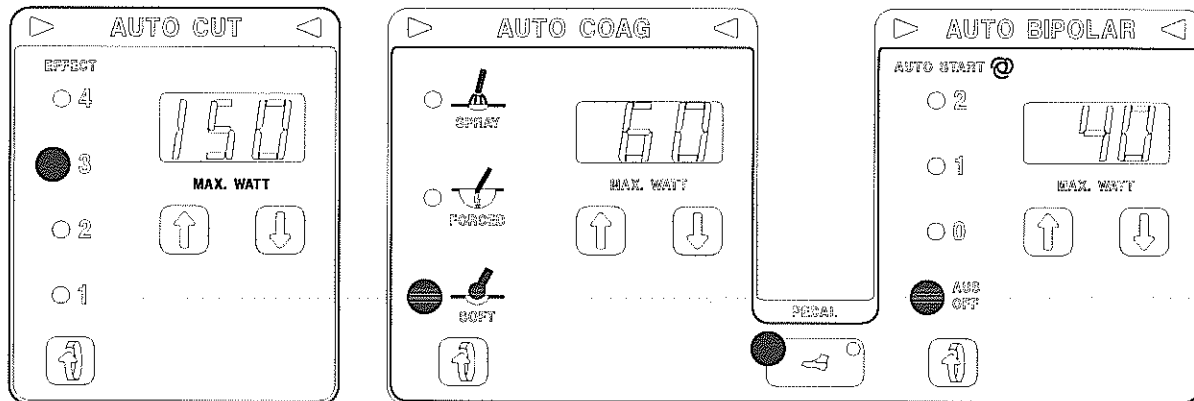

Basic setting ICC 300		
AUTO CUT	Effect 3	150 watts max.
AUTO COAG	SOFT	60 watts max.
AUTO BIPOLAR	AUTO START = off	60 watts max.
Footswitch setting	yellow = AUTO CUT	blue = AUTO COAG

Front panel of the ICC 350

After starting up the unit

Factory setting

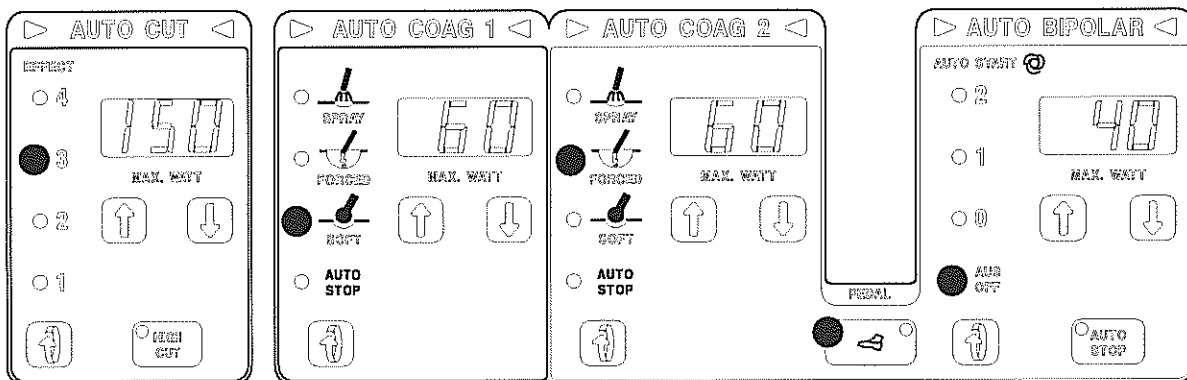

Basic setting ICC 350		
AUTO CUT	Effect 3	150 watts max.
HIGH CUT	switched off	—
AUTO COAG 1	SOFT	60 watts max.
AUTO COAG 2	FORCED	60 watts max.
AUTO BIPOLAR	AUTO START = off AUTO STOP = off	40 watts max.
Footswitch setting	yellow = AUTO CUT	blue = AUTO COAG 2

Test program no. 1

ICC 200, 300 only

General description

Using this test program, any front panel setting can be made. This setting is known as the basic setting. After termination, the basic setting is stored internally. Only completely saved channels are stored. The basic setting display flashes. Acknowledge by pressing any key.

Termination

Using "Power off".

Switch off a channel

Using the "Down" key (8), set the lowest intensity. Once the lowest display is set, the seven-segment display changes to "---". This means that the channel has been switched off.

Basic setting and brief power failure

For a brief power failure of 15 seconds max., the front panel setting last set is displayed.

Activation of a channel is blocked if a channel has not been completely set or the basic setting was not acknowledged.

The basic setting set at the factory corresponds to the FIXE basic setting.

FIXE basic setting

A FIXE basic setting is stored in the program. This basic setting is accepted and displayed if:

- the stored front panel setting is invalid, e.g. through failure of the circuit memory or through battery memory lost,
- in Test program 1, the "All off" setting has been accepted.

Test program no. 2

Call up and display of the error memory

General description

The ICC units are equipped with a system for error detection, error indication and error memory. Every error receives an error number (ERROR no.). The unit stores the last 10 ERROR numbers. Test program 2 displays the stored ERROR numbers. The most recent error occurring chronologically is in memory location 1.

Display			
AUTO CUT	AUTO COAG 1	AUTO COAG 2	AUTO BIPOLAR
Err.	1 ... 10		xxx

xxx: Display of the error number

By pressing keys 8 (Up) or 9 (Down), you can call up the memory locations one after another. By pressing key 7, you delete the error numbers at all memory locations.

Example

After starting the test program with key 3, for example, Error no. 2 appears at memory location 1 with the following display:

Display			
AUTO CUT	AUTO COAG 1	AUTO COAG 2	AUTO BIPOLAR
Err.	1		2

Test program no. 3

Test of all D-flipflop circuit memories

General description

Test of all D-flipflop (D-FF) circuit memories. After starting the test with key 3, you will see the following display:

Display (ICC 350, ICC 300)			
AUTO CUT	AUTO COAG 1	AUTO COAG 2	AUTO BIPOLAR
buS *)	0		d0 ... d7 alternating
Display (ICC 200)			
buS	d0 ... d7 alternating		

buS*) (D-FF-Test Nr. 0) tests the external control bus for signal lines d0–d7. The signal lines d0–d7 are switched on and off one after another. The switching statuses can be displayed on the bar graph (adapter board 30183-102).

Using the keys 8 (Up) or 9 (Down), you can call up D-FF tests 1-11. You will see the following display:

Display (ICC 350, ICC 300)			
AUTO CUT	AUTO COAG 1	AUTO COAG 2	AUTO BIPOLAR
dFF	1 ... 11		d0 ... d7 alternating
Display (ICC 200)			
dFF 1 ... 9	d0 ... d7 alternating		

The D-FF signal lines d0-d7 are switched on and off one after another. The signals can be measured at the D-FF outputs. There is an error if

- there is more than one output status at the same time,
- there is constantly an output signal in spite of switching over,
- there is no output signal in spite of D-FF activation.

*) buS is the seven-segment display for the word „BUS“.

Test program no. 3

Test of all D-flipflop circuit memories

Overview of the D-flipflop tests

Test no.	D-FF description	Position	Remarks
0	external control bus	Motherboard	
1	D-FF IC 2	Motherboard	
2	D-FF IC 3	Motherboard	
3	D-FF IC 9	Extra-low voltage and tone	
4	D-FF IC 19	Control board	
5	D-FF IC 20	Control board	
6	D-FF IC 6	ST power stage	
7	D-FF IC 10	Senso-board	
8	D-FF IC 8	Relay board	not ICC 200
9		Extension motherboard slot J9	not ICC 200
10		Extension motherboard slot J9	not ICC 200
11		Extension motherboard slot J9	not ICC 200

Test program no. 4

Check of the optical signals on the front panel

General description

Using this program, you can test the optical displays on the front panel. After starting the test program, you will see the following display:

All optical signals on the front panel are switched on. The 7-segment displays show “8.” for all numbers.

Test program no. 5

Sound control for all available sounds

General description

Using this program, you can test and set all available sounds. After starting the program, you will see the following display:

Display			
AUTO CUT	AUTO COAG 1	AUTO COAG 2	AUTO BIPOLAR
ton	0 ... 4		

Using the keys 8 (Up) or 9 (Down), you can set a test number from 0 to 4. The following correspondence applies between the test numbers and the sounds:

Test no.	Tones switched on	Tone variants	Remarks
0	Tone generation switched off		
1	Basic tone 1		Volume adjustable
2	Basic tone 2		Volume adjustable
3	Basic tone 3		Volume adjustable
4	Basic tone 4		Volume adjustable
		Basic tone 1 to 3	Volume adjustable
		Mixed tone: Basic tone 1 and 2	Volume adjustable
		Mixed tone: Basic tone 1 and 3	Volume adjustable
		Mixed tone: Basic tone 2 and 3	Volume adjustable
		Basic tone 1 to 3	Alarm volume
		Mixed tone: Basic tone 1 and 2	Alarm volume
		Mixed tone: Basic tone 1 and 3	Alarm volume
		Mixed tone: Basic tone 2 and 3	Alarm volume

Test program no. 5

Sound control for all available sounds

Frequency adjustment for warning tones

The warning tone frequency setting can be adjusted independently of other assemblies on the low-voltage power supply (jumper J2) with Test program no. 5.

- Activate Test program no. 5. MP 4 is GND for frequency counter.
- Call »Tone 1«: Set frequency at MP 1 with TP 2 to 493 Hz (± 2 Hz) with frequency counter.
- Call »Tone 2«: Set frequency at MP 2 with TP 3 to 414 Hz (± 2 Hz) with frequency counter.
- Call »Tone 3«: Set frequency at MP 3 with TP 4 to 329 Hz (± 2 Hz) with frequency counter.
- To check settings the various tones and mixed tones are generated one after the other by calling »Tone 4«. Here, take especial care that the operating and warning tones have different volumes.

Test program no. 6

Relay test

General description

Using this program, all relays can be actuated. The NESSY measurement monitor is switched off. After ending the test program, relay no. 1 is switched on for the power starting current limitation.

Test program no. 6 is also intended for safety testing of the unit. With this test, there may be a brief failure of the power supply due to the external intervention. If the test program is activated, the test program is automatically called up again after a brief power failure of up to approx. 15 seconds. However, if the power failure is longer than 15 seconds, this will not occur.

After starting the test program, you will see the following display:

Display			
AUTO CUT	AUTO COAG 1	AUTO COAG 2	AUTO BIPOLAR
rEL	0 ... 1		

Designation of the PCBs with their assigned relays

PCB	Slot	Relay function	Remarks
Motherboard ICC 350	–	see lines 3 and 4	
Motherboard ICC 200	–	see lines 3 and 4	
Motherboard	–	Rel. 1: Power starting current limitation	
Motherboard	–	Rel. 2: Capacitance ground	only for ICC 350
Power module	J5	Rel. 1: Switchover ST generator: HF	
ST power stage	J6	Rel. 1: Output HF: UE1 to NE	
ST power stage	J6	Rel. 2: Output HF: Rel. 3 to AE	
ST power stage	J6	Rel. 3: Output HF: UE1 to AE	
ST power stage	J6	Rel. 19: Connection to power supply	
Senso-board	J7	Rel. 1: Output NE - NESSY	
Senso-board	J7	Rel. 2: Output AE	
Senso-board	J7	Rel. 3: Output NE	
Relay board	J8	Rel. 1: Output AE 1	only ICC 300 / 350
Relay board	J8	Rel. 2: Output AE 2	only ICC 300 / 350
ICC 200: Mono output board	J8	Rel. 1: Output AE 1	only ICC 200

Test program no. 6

Relay test

Overview of the relay test options

Test no. 0 Switch off all relays		
Test object	Relay status	Remarks
Rel. 1, motherboard	switched off	Power starting current limitation
all other relays	switched off	

Test no. 1 Switch on all relays		
Test object	Relay status	Remarks
Rel. 1, motherboard	switched on	Power starting current limitation
Rel. 2, motherboard	depending on dongle installed capacitance grounded (only ICC 350)	switched on or off
all other relays	switched on	

All relays on PCBs additionally required for the ERBOTOM ICC 350 MIC are switched on.

Test program no. 7

Setting the NESSY version

General description

Using this program, you can set four NESSY versions. After starting the test program, you will see the following displays when you activate key 3:

Display			
AUTO CUT	AUTO COAG 1	AUTO COAG 2	AUTO BIPOLAR
NE.1	or		

In the AUTO COAG field:

|| means a split neutral electrode,

| means of non-split neutral electrode.

Using the keys 8 (Up) or 9 (Down), you can set four different NESSY versions:

No.	AUTO CUT	AUTO COAG 1	Remarks
1	NE.1	or	for split and non-split electrodes
2	NE.2		only for non-split electrodes
3	NE.3		only for split electrodes; acoustic (3 times) and visual alarm
4	NE.4		only for split electrodes; acoustic (continuous tone) and visual alarm

At the end of the test, the NESSY version number is stored. Version number 1 is the standard version set when the unit is delivered. In case of memory failure, version no. 1 is automatically set. When switching on the power, version no. 2, 3 or 4 is displayed briefly if this is set. The standard version no. 1 is not displayed.

Test program no. 9

Activating display programs to display measurement values

General description

This program activates displays in the standby mode or during activation. With key 3, Test program no. 9 is started.

After starting, you will see the following display:

Display			
AUTO CUT	AUTO COAG 1	AUTO COAG 2	AUTO BIPOLAR
nr.	0		

Within Test program no. 9, 22 subprograms for displaying specific data can be called up, while subprograms 16 to 22 are intended only for use by the manufacturer.

These subprograms can now be set using keys 8 (Up) or 9 (Down). Once the required display program has been selected, it is reactivated using key 3. The selected display program remains activated until the power is switched off.

Display			
AUTO CUT	AUTO COAG 1	AUTO COAG 2	AUTO BIPOLAR
nr.	0 ... 22		

Display programs nos. 1–3

The selected display program now displays the required data during regular operation of the unit. To do this, the appropriate operating modes must be set and the accessories activated.

The display program remains activated until the power is switched off. To return to normal operation, the unit must be switched off for a short time and switched back on again.

Display program no. 1: not assigned

Display program no. 2: not assigned

Display program no. 3:

ST generator time control with activation of SPRAY or FORCED.

Display for **ICC 350** and **ICC 300**:

AUTO CUT	AUTO COAG 1	AUTO COAG 2	AUTO BIPOLAR
ttt	P 2	P 3	tst

ttt Difference between set frequency and actual frequency

P 2 Set power [W]

P 3 Set power [W]

tst Abbreviation of the test title (Time-ST stage)

Display program no. 3:

ST generator time control with activation of FORCED.

Display on **ICC 200**:

AUTO CUT	AUTO COAG		
ttt	tst		

ttt Difference between set frequency and actual frequency

tst Abbreviation of the test title (Time-ST stage)

Display programs nos. 4–5

Display program no. 4:

ST generator measurement values with ST generator activation.

Output measurement values U_{st} , I_{st}

Display for **ICC 350** and **ICC 300**:

AUTO CUT	AUTO COAG 1	AUTO COAG 2	AUTO BIPOLAR
uuu	iii	P 3	UI

uuu Measurement value of the output voltage sensor

iii Measurement value of the output current sensor

P 3 Set power [W]

UI Abbreviation of the test title (Voltage and current measurement)

Display program no. 4:

ST generator measurement values with ST generator activation.

FORCED activation

Display for **ICC 200**:

AUTO CUT	AUTO COAG		
uuu	USt		

uuu Measurement value of the output voltage sensor

Display program no. 5:

Power supply unit measurement values for ST generator activation.

Measurement values U_{nt} , I_{nt}

Display for **ICC 350** and **ICC 300**:

AUTO CUT	AUTO COAG 1	AUTO COAG 2	AUTO BIPOLAR
uuu	iii	P 3	UI

uuu Measurement value of the power supply unit voltage

iii Measurement value of the power supply unit current

P3 Set power

UI Abbreviation of the test title (Voltage, current measurement)

Display program nos. 5–7

Display program no. 5:

Power supply measurement values with ST generator activation, **FORCED** activation.

Measurement values U_{nt} , I_{nt}

Display for ICC 200:

AUTO CUT	AUTO COAG
uuu	Unt

uuu Measurement value of the power supply unit voltage

Display program no. 6:

ST generator measurement values for ST generator activation, **FORCED** activation.

Measurement value I_{st}

Display for ICC 200:

AUTO CUT	AUTO COAG
iii	Ist

iii Measurement value of the output current sensor

Display program no. 7:

Power supply unit measurement values for ST generator activation, **FORCED** activation.

Measurement value I_{nt}

Display for ICC 200:

AUTO CUT	AUTO COAG
iii	Int

iii Measurement value of the power supply unit current

Display program no. 8

Display program no. 8:

Measurement values for activation of the sine-wave generator.

AUTO CUT, AUTO COAG 1 and 2 in SOFT mode, AUTO BIPOLAR

Output measurement value U_{act}

Display for **ICC 350** and **ICC 300**:

AUTO CUT	AUTO COAG 1	AUTO COAG 2	AUTO BIPOLAR
ppp	uuu	cos	PU

ppp HF power output [W], present power output

uuu HF output voltage [V], present output voltage

cos cos- ϕ -value from the table (ICC 350 only)

PU Abbreviation of the test title (Power and voltage measurement)

Display program no. 8:

Measurement values for activation of the sine-wave generator.

AUTO CUT, AUTO COAG 1 and 2 in SOFT mode, AUTO BIPOLAR

Output measurement value U_{act}

Display for **ICC 200**:

AUTO CUT	AUTO COAG
ppp	P

ppp HF power output [W]

P Abbreviation of the test title (Power measurement)

Display program no. 9

Display program no. 9:

Measurement values for activation of the sine-wave generator.

AUTO CUT, AUTO COAG 1 and 2 in SOFT mode, AUTO BIPOLAR

Output measurement values I_{real} , $\cos \varphi$ (Real part of the current and $\cos \varphi$ between voltage and current)

Display for ICC 350 and ICC 300:

AUTO CUT	AUTO COAG 1	AUTO COAG 2	AUTO BIPOLAR
iii	cos	ppp	IC

iii Real part of the measurement value from the HF output current

cos $\cos\text{-}\varphi$ value from the table (ICC 350 only)

ppp HF power output [W] for ICC 350

IC Abbreviation of the test title (Current measurement and $\cos \varphi$ measurement)

Display program no. 9:

Measurement values for activation of the sine-wave generator.

AUTO CUT, AUTO COAG 1 and 2 in SOFT mode, AUTO BIPOLAR

Output measurement value: Measurement value of the real part of the HF output current

Display for the ICC 200:

AUTO CUT	AUTO COAG
iii	I

iii Measurement value of the real part of the HF output current

I Abbreviation of the test title (Current measurement)

Display programs nos. 10–11

Display program no. 10:

Measurement values for activation of the sine-wave generator.

AUTO CUT, AUTO COAG 1 and 2 in SOFT mode, AUTO BIPOLAR

Output measurement value U_{act}

Display for the **ICC 200**:

AUTO CUT	AUTO COAG
uuu	U

uuu HF output voltage [V]

U Abbreviation of the test title (Voltage measurement)

Display program no. 11:

Measurement values for activation of the sine-wave generator.

AUTO CUT, AUTO COAG 1 and 2 in SOFT mode, AUTO BIPOLAR

Output measurement value $\cos \varphi$

Display for the **ICC 200**:

AUTO CUT	AUTO COAG
cos	Cos

cos $\cos\text{-}\varphi$ value from the table

Cos Abbreviation of the test title ($\cos\text{-}\varphi$ measurement)

Display program no. 12 (Start)

Display program no. 12:

Contact resistance at AUTO START, in standby operation.

Only valid for AUTO START 0, 1, 2 and in standby operation.

Display for ICC 350 and ICC 300:

AUTO CUT	AUTO COAG 1	AUTO COAG 2	AUTO BIPOLAR
uuu	P2	P3	br

uuu Measurement value of the contact monitor voltage measurement

P2 Set power for AUTO COAG 1 [W]

P3 Set power for AUTO COAG 2 [W]

br Contact monitor

Display program no. 12:

Contact resistance for AUTO START, in active condition.

Only valid for AUTO START 0, 1, 2 and in active condition.

Display for ICC 350 and ICC 300:

AUTO CUT	AUTO COAG 1	AUTO COAG 2	AUTO BIPOLAR
rda	P2	P3	br

rda Calculated value of the contact resistance [ohms]

P2 Set power for AUTO COAG 1 [W]

P3 Set power for AUTO COAG 2 [W]

br Contact monitor

Display program no. 12 (continued)

Display program no. 12:

Contact resistance for AUTO START, in standby operation.

Display for ICC 200:

AUTO CUT	AUTO COAG
uuu	br

uuu Measurement value of the contact monitor voltage measurement

br Contact monitor

Display program no. 12:

Contact resistance for AUTO START, in active condition.

Display for ICC 200:

AUTO CUT	AUTO COAG
rda	br

rda Calculated value of the contact resistance [ohms]

br Contact monitor

Display program no. 15

Display program no. 15:

NESSY transition resistance in stand-by-operation and on activation.

Display for **ICC 350 and ICC 300:**

AUTO CUT	AUTO COAG 1	AUTO COAG 2	AUTO BIPOLAR
rtr	P2	P3	br

rtr calculated NESSY transition resistance [Ohm]

P2 set power for AUTO COAG 1 [W]

P3 set power for AUTO COAG 2 [W]

br AUTO START monitor

Display program no. 15:

NESSY transition resistance in stand-by-operation and on activation.

Display for **ICC 200:**

AUTO CUT	AUTO COAG
rtr	r

rtr calculated NESSY transition resistance [Ohm]

r AUTO START monitor

Display programs nos. 13–22

NOTE

Display programs nos. 13 and 14 are not assigned. The program nos. 17–22 are only intended for internal use by the manufacturer.

Test program no. 10

Changing the maximum time limit

General description

Using this program, you can change the time limit for the ICC 200, 300 and 350. The setting range varies from 3 to 960 seconds.

Using the appropriate “Up” or “Down” keys, the time limit restriction for every current quality can be set individually.

For the ICC 350, various time limit settings can be stored in the individual program memories for each user. This occurs after selecting the program number with program memory key 2 and then changing the respective current qualities using the appropriate “Up” or “Down” key.

After termination of Test program 10 using key 3, the settings made are stored.

In case of memory failure, as well as in the delivery condition, the max. time limit for all programs and current qualities (CUT, COAG 1, COAG 2, BIPOLAR) is set at 90 seconds.

After starting Test program 10 with key 3, you will see the following display:

AUTO CUT	AUTO COAG 1	AUTO COAG 2	AUTO BIPOLAR
t1	t2	t3	t4

- t1: Time limit restriction for AUTO CUT in seconds
- t2: Time limit restriction for AUTO COAG 1 in seconds
- t3: Time limit restriction for AUTO COAG 2 in seconds
- t4: Time limit restriction for AUTO BIPOPLAR in seconds.

Using the following keys, you can adjust the max. time limit (see page 1-4):

- AUTO CUT : Keys 4 and 5
- AUTO COAG 1 : Keys 8 and 9
- AUTO COAG 2 : Keys 11 and 12
- AUTO BIPOLAR: Keys 15 and 16

Test program no. 11

Measurement value output for the measurement channels

Using this program, you can measure the internal supply voltages and the temperature of the unit. In addition, you can display all analog direct measurement channels 1, 2, 3 and 4 as well as analog multiplex measurement channels.

After starting the test program, you will see the following display:

Display ICC 350 / 300			
AUTO CUT	AUTO COAG 1	AUTO COAG 2	AUTO BIPOLAR
U	0		XX.X
U-	1		XX.X
U	2		XX.X
tPt	ttt		xxx
Ch	4 ... 22		yyy

- XX.X Voltage value [V]
- ttt Temperature [°C]
- xxx ADC measurement value in the range 0 ... 255
- yyy ADC measurement value in the range 0 ... 255

Using the keys “Up” (8) or “Down” (9), call up the subprograms U, U-, tPt and Ch 4 ... 22.

U0 is the low voltage controlled to +15 volts $\pm 10\%$

U-1 is the low voltage controlled to -15 volts $\pm 10\%$

U2 is the low voltage controlled to 24 volts $\pm 10\%$

tPt is the temperature display of the output stage $\pm 15\%$

Ch4 ... 22 are the analog measurement channels according to the following table:

Display ICC 200			
AUTO CUT	AUTO COAG 1	AUTO COAG 2	AUTO BIPOLAR
U.15	XX.X		
-15	XX.X		
U.24	XX.X		
tPt	ttt		
C.aa	yyy		

Test program no. 11

Measurement value output of the measurement channels

- XX.X Voltage rating [V]
- ttt Temperature [°C]
- C.aa Channel number
- yyy ADC measurement value in the range 0 ... 255

Using the “Up” (8) or “Down” (9) keys, call up the subprograms U, U-, tPt und C. 4-22.

U0 is the supply voltage controlled to +15 volts

U-1 is the supply voltage controlled to -15 volts

U2 is the supply voltage controlled to +24 volts

tPt is the temperature display of the output stage

C. 4 ... 22 are the analog measurement channels according to the following table.

Voltage test U 0 or U.15

Measurement and display of the supply voltage controlled to +15 volts

Display XX.X: e.g. 14.6 equals 14.6 volts

Voltage test U-1 or -15

Measurement and display of the supply voltage controlled to -15 volts

Display XX.X: e.g. 14.6 equals -14.6 volts

Voltage test U 2 or U.24

Measurement and display of the supply voltage controlled to +24 volts

Display XX.X: e.g. 23.6 equals +23.6 volts

Measurement of the output stage temperature

Display tPt 25 means that the temperature inside the unit is 25 °C.

Test of the analog measurement channels (Subtest 4 ... 22)

Measurement and display of 19 analog measurement channels inside the unit.

(Intended for internal use by the manufacturer only).

Test program no. 12

Setting the FORCED voltage

General description

When this program is called up, the set FORCED version is displayed. Using the “Up” (8) or “Down” (9) keys, you can set one of three (V2.0) or four (V4.0) FORCED versions.

With FORCED coagulation, the ST pulse generator produces short pulses with a high no-load voltage. The high no-load voltage has both advantages and disadvantages which are described in this section with the features.

Using Test program 12, the no-load voltage can be changed relative to the set power limitation.

After starting the test program, you will see the following display:

AUTO CUT	AUTO COAG 1	AUTO COAG 2	AUTO BIPOLAR
For.	vs nr		

For. Voltage limitation for FORCED coagulation

vs nr: FORCED version nos. 1...3 (V2.0) or 1...4 (V4.0)

Call up the version number using the “Up” (8) or “Down” (9) keys.

Forced version vs nr 1

A power limitation of 1 to 30 watts increases the no-load voltage constantly up to approx. 1,300 V_p.

Above 30 watts power limitation, the no-load voltage is limited to approx. 1,300 V_p.

Characteristics of the version vs nr 1

- Minimal image interference on monitors.
- Danger of burns from contact with a terminal.
- Good coagulation via a terminal without heavy spark formation.
- No heavy spark formation even at a high power setting.
- To direct power into the tissue, the tissue must be contacted (No power transmission via spark).

FORCED version vs nr 2

A power limitation of 1 to 30 watts increases the no-load voltage constantly up to approx. 1,300 V_p. Above 30 watts power limitation, the no-load voltage continues to increase:

No-load voltage at 40 watts: approx. 1,500 V_p

No-load voltage at 50 watts: approx. 1,700 V_p

No-load voltage at 60 watts: approx. 1,900 V_p

No-load voltage from 80 to 120 watts: approx. 2,300 V_p.

Test program no. 12

Setting the FORCED voltage

Characteristics of version vs nr 2

The characteristics are between those of the vs nr 1 and those of the vs nr 3.

FORCED voltage version vs nr 3

A power limitation of 1 to 30 watts increases the no-load voltage constantly up to approx. 2,300 V_p. Above 30 watts power limitation, the no-load voltage is limited to approx. 2,300 V_p.

Characteristics of version vs nr 3

- Image interferences on monitors possible.
- Danger of burns from contact with a terminal possible.
- Heavy spark formation with coagulation via a terminal.
- Heavy spark formation also at a 30 watts power setting.

To direct high-frequency power into the tissue, the tissue must not necessarily be contacted (current flow or powered transmission [see vs nr 2] possible via arc).

FORCED voltage version vs nr 4

A power limitation of 1 to 30 watts increases the no-load voltage constantly up to approx. 2,600 V_p. Above 30 watts power limitation, the no-load voltage is limited to approx. 2,600 V_p.

Characteristics of version vs nr 4

- Image interference on monitors possible.
- Danger of burns from contact with a terminal possible.
- Heavy spark formation with coagulation via a terminal.
- Heavy spark formation also at a 30 watts power setting.

To direct high-frequency power into the tissue, the tissue must not necessarily be contacted (current flow or powered transmission [see vs nr 2] possible via arc).

Important notes

- The vs no set only applies to FORCED AUTO COAG 1, FORCED AUTO COAG 2 and for programs 0 to 11.
- For the MIC program, vs nr 1 is automatically set.
- In case of memory failure, vs nr 1 is automatically set.

When switching on the power supply, vs nr 2, vs nr 3 or vs nr 4 (V4.0) is briefly displayed. The standard vs nr 1 is not displayed.

Test program no. 16

Pre-information:

Recommended measuring equipment

Measuring equipment

To service equipment from the ICC series, various meters are necessary. The following list summarizes recommended measuring equipment for a quick overview.

ATTENTION ! 

Individual parts and boards are at supply voltage potential. After removing the housing cover, there is risk of electrical shock due to unintentional contact with the power plug connected.

The HF power meter, the oscilloscope and the frequency counter must be operated as floating.

The unit contains a lithium battery which must only be discarded in battery collection containers in completely discharged condition (i.e. after use). Otherwise, care must be taken to prevent shorting in accordance with the battery regulations.

Measuring equipment	EE order no. (230 V; 50/60 Hz)	EE order no. (120 V; 50/60 Hz)
Testbox 2	20183-040	20183-041
70 V testbox for spark monitor ICC	20100-019	20100-028
HF power meter	—	
Isolating transformer for APM 600	20100-013	
Adapter cable for NESSY monitor	20100-003	
Bipolar adapter cable	20100-004	
Measurement cable for LF patient leakage current	20100-009 (standard)	
Measurement cable for LF patient leakage current	20100-012 (international)	
2-channel oscilloscope (> 40 MHz)	—	
Frequency counter	—	
Multimeter with μ A range	—	
Bipolar testbox automatic starter ICC	20100-017	
Extension board	30183-106	

Test program no. 16

Pre-information: Jumper on the display board

General information

On the display board, there are slots for jumper which, by plugging in so-called “jumpers”, can activate special software by which our HF surgical units from the ICC series can be adapted to prescribed special conditions (such as are necessary in various countries) or by means of which specific tests can be performed by the testing department and service.

WARNING



These jumpers are already positioned during production and must never be changed randomly. For a software update, make certain that the jumpers are correctly plugged in. Back-up plugs are in the bag with the spare fuses.

Where are the slots for the jumpers?

If you look at the display board inside the open unit from the perspective of the rear panel, the following stylized image can be seen:

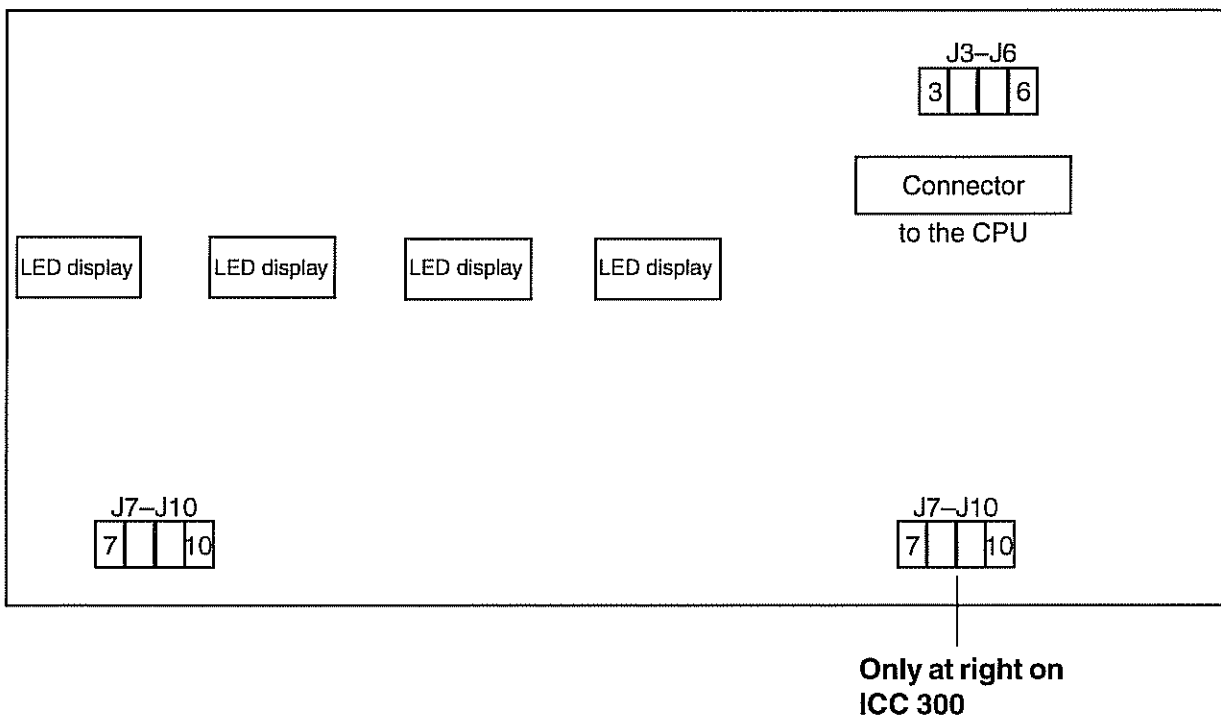

Two blocks are available to receive jumpers: At the top right is a block with the slots J3-J6, at the bottom left (ICC 300: bottom right) is the block with the slots J7-J10.

Test program no. 16

Pre-information: Jumper on the display board

Block 1

Pos.	Function	Jumper plugged in	Jumper <i>not</i> plugged in
J3	Only ICC 350: Switchover of neutral electrode to "capacitance grounded" or "floating output".	Output circuitry with capacitance ground.	Output circuitry is "floating output".
J4	Only for test purposes. Temperature display.	Maximum temperature of generator is displayed (ERROR 11).	The unit is delivered with this setting.
J5	J5 functions together with J6.	(see following explanation)	(see following explanation)
J6	J6 functions together with J5.	(see following explanation)	(see following explanation)

The J5 and J6 slots are read by the CPU as a binary number. In this way four different functioning methods, independent from one another, are programmable by plugging in these jumpers:

J5	J6	Description of the set function
free	free	None of the following 3 programs is selected.
plugged	free	Contact monitor is blocked and AUTO START display is "off".
free	plugged	During activation, another activation signal from some other source has switched off the unit activation (Spanish regulation).
plugged	plugged	F leakage current > 150 mA, but < 300 mA: Triple visual and acoustic alarm is triggered. HF leakage current > 300 mA: The HF generator is switched off. Visual and acoustic alarm is triggered.

Test program no. 16

Pre-information: Jumper on the display board

Block 2 (as of Version 1.06)

Pos.	Function	Jumper plugged in	Jumper <i>not</i> plugged in
J7	(not in use)	(not applicable)	(not applicable)
J8	Low-resistance load operation < 5 ohms triggers ERROR 30 to protect accessories and generator. ERROR 30 can be deactivated here when activating AUTO BIPOLAR.	Deactivation of ERROR 30 possible for BIPOLAR COAG (as of V 2.00): - after 4 s red LED (output error) - Output current max. 1.5 A - no ERROR indication (This specification especially applies to the USA.)	ERROR 30 warning appears due to delivery status (not USA, ERROR 30 deactivated here).

Regardless of the selection, special settings are necessary for specific countries. These can be found in the following matrix. Explanation:

- 1 Jumper must be plugged in,
- o Jumper must not be plugged in,
- x (according to the description for Block 1).

Country	J5	J6	J7	J8
Germany	o	o	no function	per above table
European countries (excepted: see below)	o	o	no function	per above table
Great Britain	1	o	no function	per above table
Spain	o	1	no function	per above table
Japan	1	1	no function	per above table
USA	x	x	no function	1

Test program no. 16

Pre-information: Jumper on the display board

Note regarding ERROR 30

With bipolar coagulation, it may happen that, over a longer period of time, a short circuit occurs on one of the bipolar forceps. Particularly for thin forceps, there is a danger with a short circuit that the forceps begin to glow due to the high current and the HF generator is damaged due to a mismatch.

Since tissue resistance quickly reaches values above 50 ohms during a coagulation process with conventional bipolar instruments, normally after starting the coagulation by desiccating the tissue, it is assumed that, with a continuously low resistance of less than 50 ohms, an error status results which is indicated by ERROR 30.

In addition, there are large-area coagulation forceps for which a resistance less than 50 ohms is set, insofar as the legs are only open to a small degree. If the operating surgeon activates such an instrument with a small leg opening, ERROR 30 is indicated after approx. 5 seconds and activation is switched off. This error message is felt to be a nuisance by some operating surgeons. In these particular cases, the ERROR 30 error message can be switched off on units above Version 2.00 by means of the jumper in position J8. In this case, at a resistance less than 50 ohms, the output current of the ICC is limited to 1.5 A.

WARNING



For a power setting greater than 20 W, there is a danger of destroying the HF generator after approx. 1 minute during short-circuit operation. There is no warning if the ERROR 30 error message is switched off.

Test program no. 16

General description

General description

All adjustment work is performed solely with the help of this test program. Here the sequence from Adjustment 1 to Adjustment 13 must be followed.

Ending the test is only possible at the setting Adjustment 0 (as of 0 in the display).

If Test program 16 is activated, the test program is automatically called up again if there is a brief power failure lasting up to approx. 15 seconds. If the power failure lasts longer than 15 seconds, the test program is no longer automatically called up.

This text describes only the function of the program. The unit is adjusted according to the adjustment instructions. These adjustment instructions are a component of the service documents.

After starting the test program with key 3, you will see the following display:

Display ICC 350 / 300			
AUTO CUT	AUTO COAG 1	AUTO COAG 2	AUTO BIPOLAR
Ab	xx (0 ... 13)		

xx Adjustment test number (beginning with 0)

Display ICC 200	
AUTO CUT	AUTO COAG
Ab	xx

xx Adjustment test number (beginning with 0)

Adjustment 0 permits entry and exit from Test program 16.

Test program no. 16

List of individual adjustments

Test program 16: List of individual adjustments	
Adjustment	Function of the adjustment
1	Phase relationship of the power supply unit
2	Current/voltage setting of the power supply unit
3	Setting of the actuation pulse length for the HF generator
4	Phase relationship of the HF generator
5	Current/voltage setting of the HF generator
6	Current/voltage setting of the amplified measurement values of the HF generator
7	Phase angle setting (cos Phi)
8	Adjustment of the function monitor sensor
9	NESSY adjustment: Contact resistance
10	HF leakage current monitor
11	Starting threshold of the contact monitor
12	Length of actuation pulse and frequency setting of the ST generator
13	LF leakage current measurement and setting help for CF

Using the “Up” (8) and “Down” (9) keys, call up an adjustment test number. Start the adjustment test with key 3.

Adjustment

Air. No. 80716-207
09/2004

Adjustment 1

Power supply unit phase relationship

Procedure

- Unplug power cable from the ERBOTOM ICC.
- Pull off the black lines on the bridge-connected rectifier BR 1 on the motherboard and connect an adjustable isolating transformer to BR 1 in its place, the output voltage of which is adjusted to 0 V. With *well prebalanced* boards, a transformer with a fixed voltage of approx. 155 V AC can also be used.

ATTENTION !

For units which are set to 120 V, you must absolutely make certain that the Erbotom ICC is operated via an isolated transformer. In addition, the connection between J15 and J20 on the motherboard must be removed from J15.

- Connect 200 ohms load resistance (e.g. APM 600) to MP1 = GND and MP2 on the power module (slot J5).
- Connect the oscilloscope to MP1 = GND and MP2 = probe on QC power stage end stage (slot J4).
- Plug the power cable for the Erbotom ICC back in and activate Test program 16, Adjustment 1.
- Activate using the yellow pedal on the footswitch (AUTO CUT).
- Slowly increase the output voltage on the isolating transformer. With a correct setting, the voltage characteristic corresponds to the graph illustrated below, whereby the small dip (approx. 20 V) next to the square-wave edges represent a good criterion of evaluation for this.
- Set the phase angle using TP13 (control board, slot J3). For the final setting, the square-wave voltage must be increased to approx. ± 100 V. (Display in AUTO CUT approx. 205).
- After the setting is complete, disconnect the ERBOTOM ICC from the power, remove the cable from the isolating transformer to BR1 and connect the two black lines again to the bridge-connected rectifier.

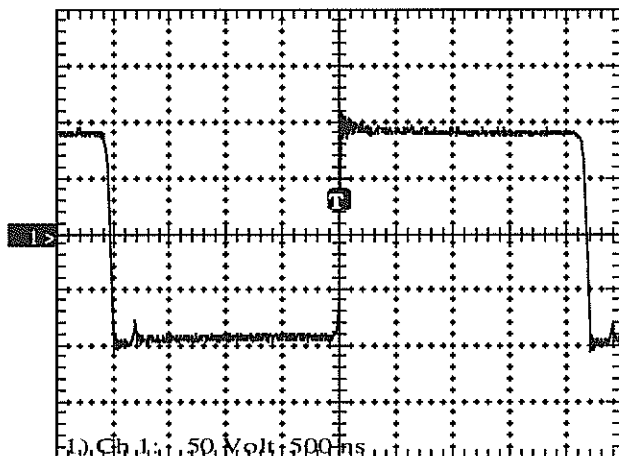
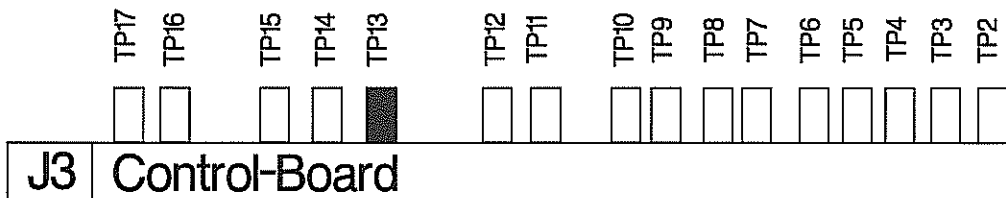
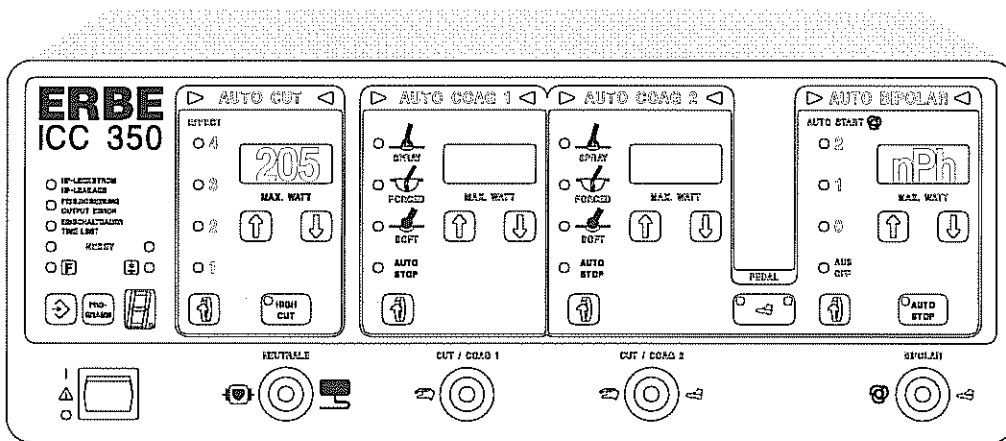

Fig.: Voltage characteristic of supply unit power

Adjustment 1

Power supply unit phase relationship



ICC 350 ICC 300				
AUTO CUT	AUTO COAG 1	AUTO COAG 2	AUTO BIPOLAR	
Ab			nPh	before activation
U NTG			nPh	during activation

ICC 200		
AUTO CUT	AUTO COAG	
Ab	nPh	before activation
U NTG	nPh	after activation

- U NTG Power supply unit voltage [V]
- nPh Adjustment of the phase relationship for the power supply unit generator

Question 2

Art. No.: 80116-201
09/2004

Adjustment 2

Power supply unit output parameters

Procedure

- Connect 500 ohms load resistance (APM 600) to MP1 = GND and MP2 = +U on “Power Module” board (slot J5).
- Plug in the power cable on the ICC.
- Call up Test program 16, Adjustment 2.
- Activate ERBOTOM ICC using the yellow footswitch pedal (AUTO CUT).
- Set TP2 on the control board (slot J3) in such a way that 100 W (tolerance +0% / -7%) can be measured at the HF power meter and a power supply current of 447 mA (tolerance 444...455 mA) is displayed in the AUTO COAG 1 display. In the AUTO CUT display, a power supply voltage of 223 V (tolerance 223...227 V) is displayed.
- Disconnect the ICC from the power and remove the connecting cable from MP1 and MP2.

ICC 350 ICC 300				
AUTO CUT	AUTO COAG 1	AUTO COAG 2	AUTO BIPOLAR	
Ab	2		nUI	before activation
U NTG	I NTG	I NTG V1	nUI	during activation

- U NTG Power supply voltage [V]; Set value = 223 V
- I NTG Power supply current [mA]; Set value = 447 mA
- I NTG V1 Amplified power supply current [mA]
- nUI Adjustment of the current voltage setting of the power supply generator

ICC 200		
AUTO CUT	AUTO COAG	
	nUI	before activation
U NTG	I NTG	after activation

- U NTG Power supply voltage [V]; Set value = 223 V
- I NTG Power supply current [mA]; Set value = 447 mA

Adjustment 2

Power supply unit output parameters

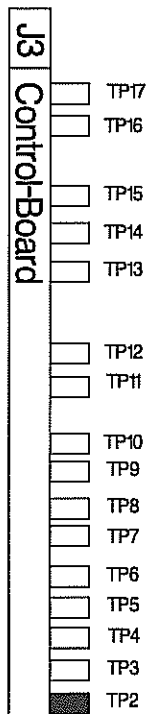
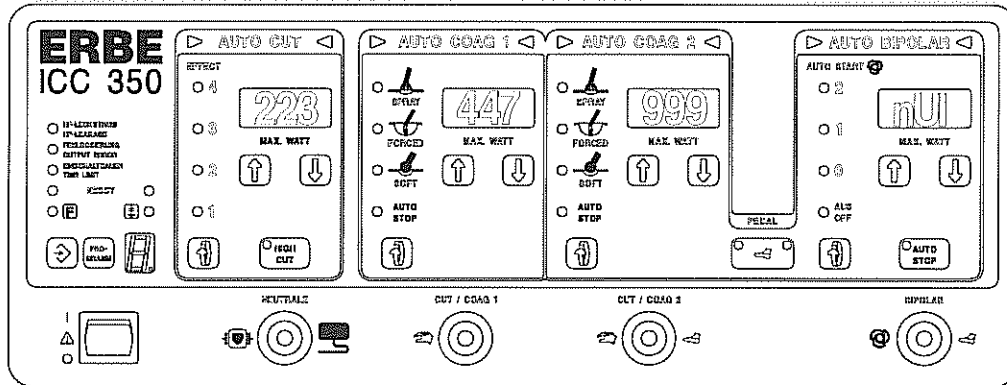

Art. No.: 80116-201
09 / 2004

Adjustment

Aid. No.: 80115-201
09/2004

Adjustment 3

Actuation pulse length HF generator

Procedure

- Measure the actuation pulse TS1 on the control board (slot J3) with an oscilloscope at measuring point MP6 = GND and MP2 = probe tip.
- Switch on the ICC and call up Test program 16, Adjustment 3.
- Using TP14 on the control board (slot J3), set a pulse length of 350 ns.
ATTENTION: Pulse is inverted.
- Disconnect the ICC from the power.
- Remove the probe from MP6 and MP2.

ICC 350 ICC 300				
AUTO CUT	AUTO COAG 1	AUTO COAG 2	AUTO BIPOLAR	
Ab	3		thF	auto. activated

- thF Pulse length of the HF generator [ms]; Set value = 350 ns

ICC 200		
AUTO CUT	AUTO COAG	
	thF	auto. activated

- thF Pulse length of the HF generator [ms]; Set value = 350 ns

Adjustment 3

Actuation pulse length HF generator

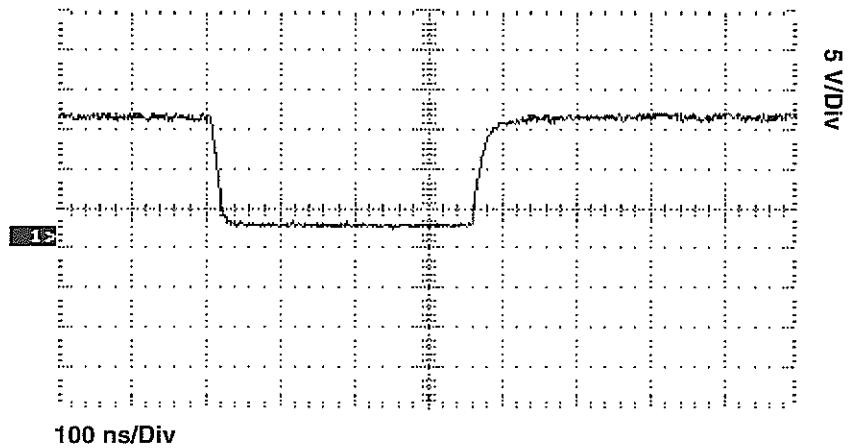
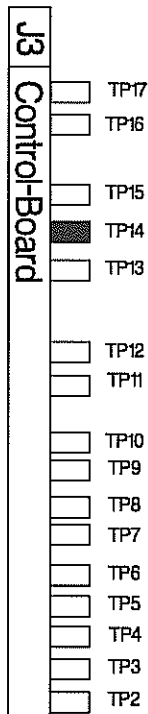
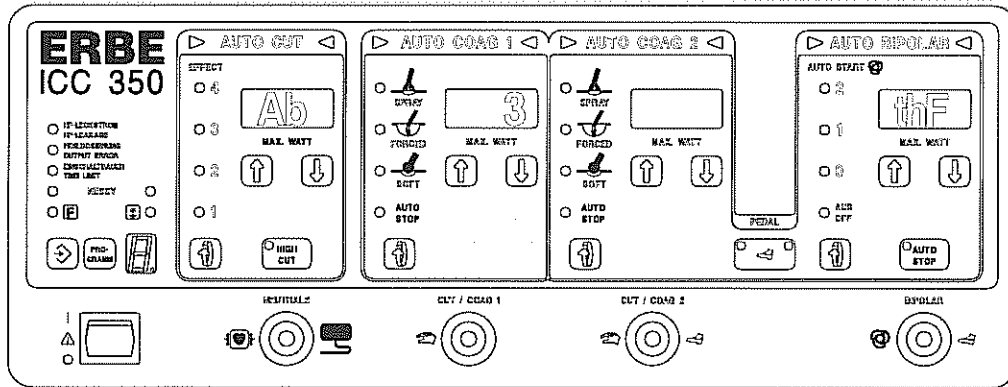

Fig.: Transistor switching pulse

Appendix 4

Art. No.: 80116-201
09/2004

Adjustment 4

Phase relationship HF generator

Procedure

- Switch the ICC back on and call up Test program 16, Adjustment 4.
- With probe 100 : 1, the no-load HF output voltage between the active and neutral electrode must be measured; for 2 monopolar outputs: Output CUT / COAG 2.
- Activate the ICC using the yellow footswitch pedal (AUTO CUT).
- Observing the output voltage form, increase the power supply voltage in the CUT field (AUTO CUT display corresponds to the set power supply voltage; AUTO COAG 1 display corresponds to the actual power supply voltage). Using TP15 on the control board (slot J3), a symmetrical sine-wave characteristic must be set.
- At a maximum power supply voltage (= 250 V), make the final adjustment. At the same time, set a good symmetrical sine-wave shape and a minimum power supply current (= display in AUTO BIPO-LAR field), which means a minimal no-load power loss (see Fig.). CAUTION: The best possible sine-wave characteristic has priority over the absolute current minimum.

ICC 350 ICC 300				
AUTO CUT	AUTO COAG 1	AUTO COAG 2	AUTO BIPOLAR	
U SOLL = 30 V	4		Ph	before activation
U SOLL	U NTG	I NTG V1	I NTG	during activation

- U SOLL Set power supply voltage [V]
- U NTG Power supply unit voltage [V]
- I NTG V1 Amplified power supply current [mA]
- I NTG Power supply current [mA]

ICC 200		
AUTO CUT	AUTO COAG	
U SOLL (Start = 30 V)	nPh	before activation
U SOLL	U NTG	after activation

- U SOLL Set power supply voltage [V]
- U NTG Power supply unit voltage [V]

Adjustment 4

Phase relationship HF generator

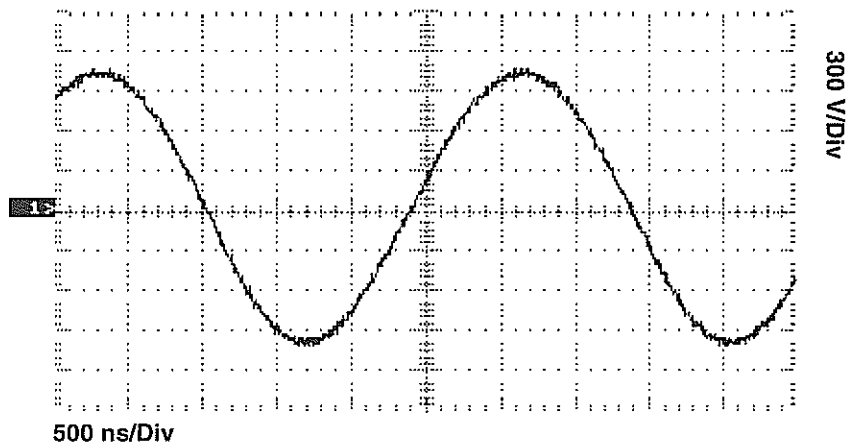
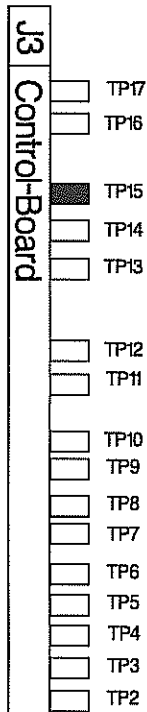
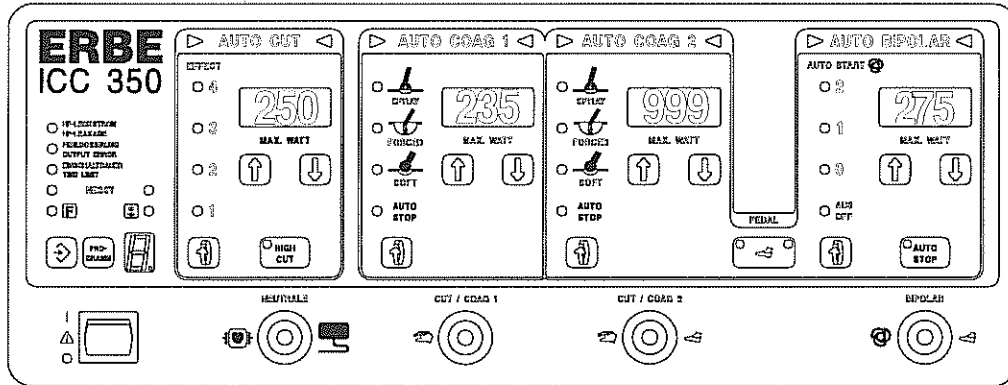

Fig.: HF no-load voltage

Adjustment 5

Air. No.: 8016-201
09/2004

Adjustment 5

HF generator output parameters

Procedure

- Call up Test program 16, Adjustment 5.
- Connect the HF power meter, e.g. APM 600 (set to 500 ohms) via active cable to active and neutral electrode output sockets on the ICC; for 2 monopolar outputs: CUT / COAG 2 output and NE socket.
- Activate the unit with the yellow pedal of the footswitch (AUTO CUT).
- Using TP3 on the control board (slot J3), the HF output voltage is set in such a way that a power of 100 watts is indicated on the HF power meter and a value of 223 volts HF effective voltage (tolerance 220...223 volts) in the display on the AUTO CUT field.
- Under certain conditions, TP 4 (HF current limitation) must be turned back far enough before this setting so that no current limitation is effective.
- Using TP4 on the control board (slot J3), the HF current limitation is set in such a way that a value of 447 mA effective HF current (tolerance 439...447 mA) with constant power output appears in the AUTO COAG 1 field.
- Insofar as the measurement of the phase angle between HF voltage and HF current produces a value greater than 98 (which is $100 \cdot \cos \phi$) at this setting in the AUTO COAG 2 field, a value of 100 watts HF power output is displayed (tolerance 97...100 watts) in the AUTO BIPOLAR field after correct adjustment of voltage and current.
- For the voltage characteristic at a 500 ohms load, see Fig.

ICC 350 ICC 300				
AUTO CUT	AUTO COAG 1	AUTO COAG 2	AUTO BIPOLAR	
Ab	5		UI	before activation
U HF	I HF	cos Phi	P	during activation

ICC 200		
AUTO CUT	AUTO COAG	
	UI	before activation
U HF	I HF	after activation

- U HF HF voltage [V]; Set value = 223 V
- I HF Real part of HF current [mA]; Set value = 447 mA

Adjustment 5

HF generator output parameters

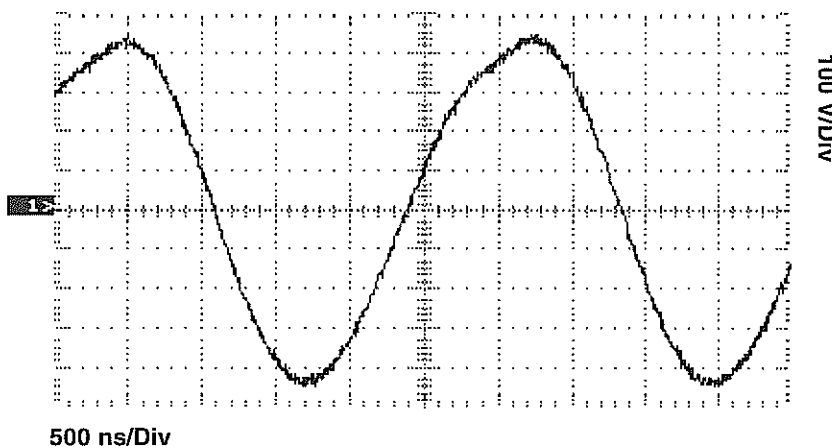
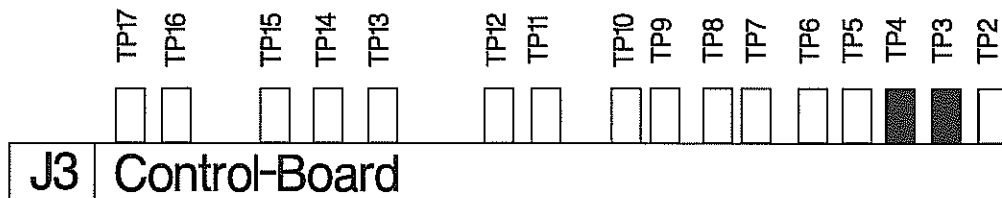
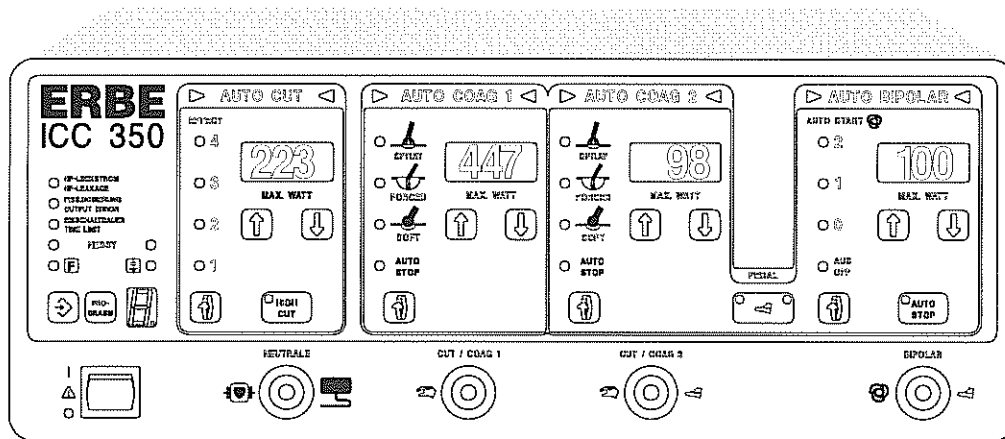

Fig.: HF voltage at R = 500 ohms

- $\cos \Phi$ Phase angle 0...100*) Set value = 100
- P Emitted active power [W]; Set value = 100 watts at 500 R

$\cos-\phi$ display, when the “Up” (8) key is pressed.

P display, when the “Down” (9) key is pressed.

*)To avoid decimal places, the value of the table value of $\cos \phi$ is indicated times 100, such that 100 means $\cos \phi = 1$.

Adjustment 6

Alt. No.: 80116-201
08 / 2004

Adjustment 6

HF generator output parameters amplified

Procedure

- Call up Test program 16, Adjustment 6.
- With the same setup as for Adjustment 5, the unit is activated. At the same time, 5 watts (tolerance 4.5...5.5 watts) should be output at the HF power meter.
- Using TP 5 on the control board (slot J 3), the amplified HF voltage measurement is set in such a way that a value of 50 volts HF output voltage is displayed in the AUTO CUT field.
- Using TP 6 on the control board, the amplified HF current measurement is set. The value 100 mA Hf output current is displayed in the AUTO COAG 1 field when set correctly.
- In the Auto Bipolar field, the emitted active power is displayed.
- In the Auto Coag 2 field, the phase angle $\cos \varphi$ is displayed.

ICC 350 ICC 300				
AUTO CUT	AUTO COAG 1	AUTO COAG 2	AUTO BIPOLAR	
Ab	6		UI	before activation
U HF	I HF	cos Phi	P	during activation

ICC 200		
AUTO CUT	AUTO COAG	
	UI	before activation
U HF	I HF	after activation

- U HF HF voltage amplified [V]; Set value = 50 V
- I HF Real part of the amplified HF current [mA]; Set value = 100 mA
- cos Phi Phase angle 0...100 from the table Set value = 100
- P Emitted active power [W]; Set value = 5 watts at 500 R

ICC 200:

cos-φ display appears when the “Up” (8) key is pressed.

P-display appears when the “Down” (9) key is pressed.

Adjustment 6

HF generator output parameters amplified

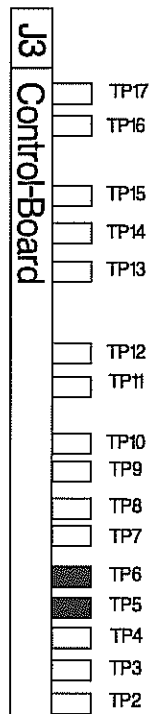
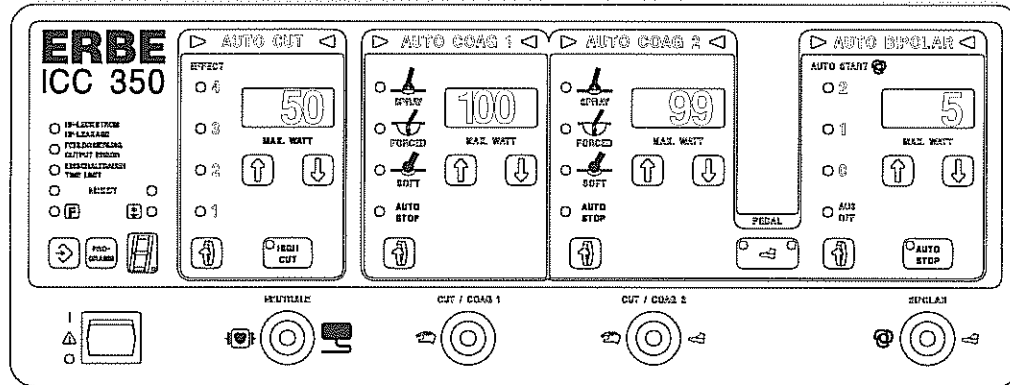

Art. No.: 80116-201
08 / 2004

Appendix 7

Art. No.: 60116-201
09/2004

Adjustment 7

Phase angle ($\cos \varphi$)

Procedure

- Call up Test program 16, Adjustment 7.
- Using ERBE original cable, connect the APM 600 (set at 500 ohms) to the ICC; with 2 monopolar connections: Connect active output socket: CUT / COAG 2 (ICC 300 / 350) and NE socket.
- Connect a capacitor with 1 nF (e.g. ERBE component no. EE 51103-026) with short lines across the active electrode and NE sockets on the HF power meter.
This produces a phase shift between voltage and current of 45° at a frequency of 340 kHz.
- Activate the cut footswitch.
- Using TP 7 on the control board (slot J3), the unit is set in such a way a value of 73 (display is $100 \cdot \cos \varphi$) is displayed in the AUTO CUT field and a value of 120 (analog / digital converter measured value) is displayed in the AUTO COAG 1 field.

ICC 350 ICC 300				
AUTO CUT	AUTO COAG 1	AUTO COAG 2	AUTO BIPOLAR	
Ab	7		PHI	before activation
COS	xxx		PHI	during activation

ICC 200		
AUTO CUT	AUTO COAG	
	PHI	before activation
COS	xxx	after activation

- COS $\cos\text{-}\varphi$ values from table; Set value = 73
0 means phase shifting = 90°
100 means phase shifting = 0°
- xxx Analog $\cos\text{-}\varphi$ measurement value; Range 0...255
- V_{eff} HF output voltage;
200 mA output current limitation

Adjustment 7

Phase angle ($\cos \varphi$)

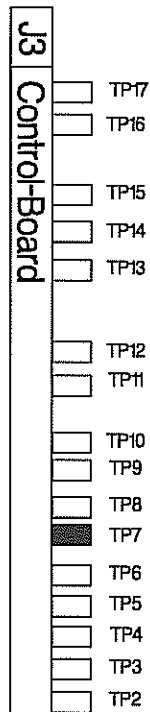
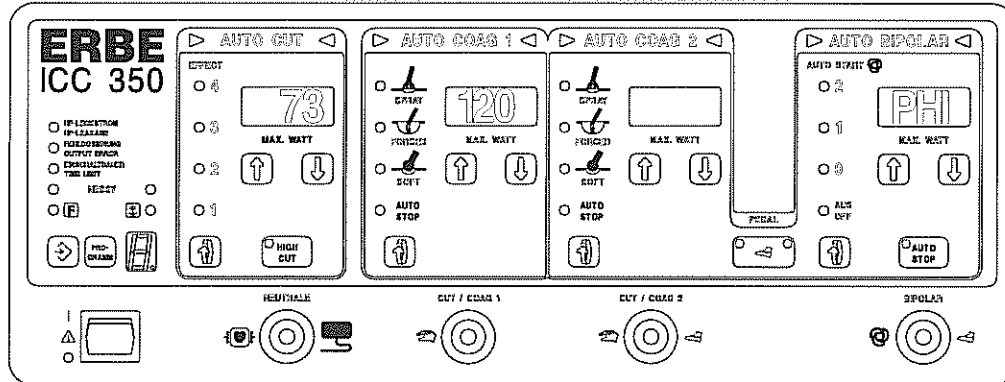

Art. No.: 80116-201
09/2004

Adjustment

Aid. No.: 60116-201
09/2004

Adjustment 8

Spark monitor

Procedure (also applies to the units without HIGH CUT or ENDO CUT)

- On the ICC 300 and ICC 200 without ENDOCUT, TP8 should be set to the upper limit (to do this, turn TP8 clockwise).
- Call up Test program 16, Adjustment 8.
- A DC voltage of 70 volts is fed into the patient circuit between the center control for the active AE socket (with 2 monopolar outputs: Output CUT / COAG 2) and the neutral electrode NE socket (AE = +, NE = -). To do this, the ERBE TESTBOX 70 volts is recommended (ERBE Order no. 20100-019).
- Adjust TP8 on the control board (slot J3) is set in such a way that a measurement value of 77 is indicated for the A/D converter, and a value of 70 volts DC is displayed in the AUTO COAG 1 field. On the ICC 200 ENDOCUT, this value appears in the AUTO CUT field, while the A/D converter value is not shown.

ICC 350				
AUTO CUT	AUTO COAG 1	AUTO COAG 2	AUTO BIPOLAR	
xxx	yyy		FU	Standby

ICC 200 ENDO CUT		
AUTO CUT	AUTO COAG	
yyy	FU	Standby

- yyy Fed-in DC voltage for the spark measurement value (70 V)
- xxx Analog spark measurement value

The input for applying the test DC voltage is the CUT / COAG 2 socket.

Adjustment 8

Spark monitor

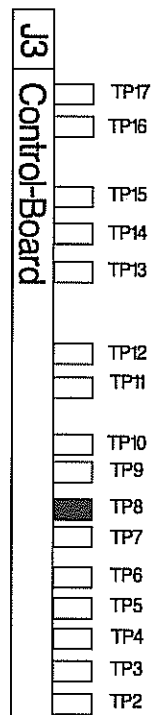
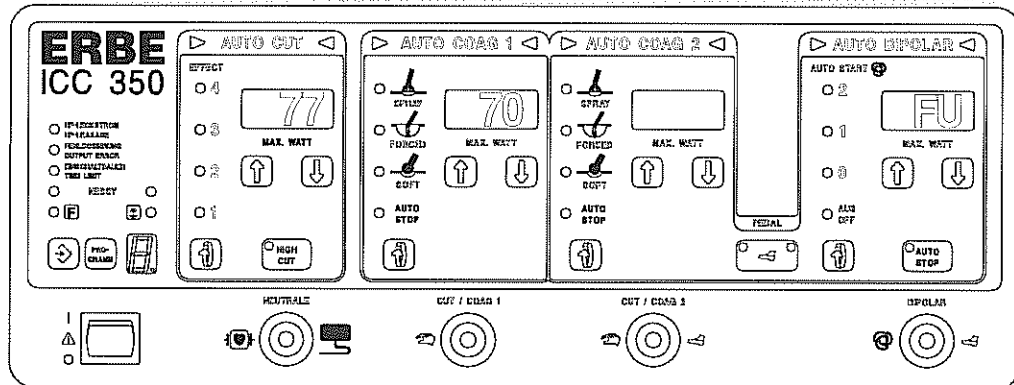

Art. No.: 80116-201
09 / 2004

Adjustment

Air. No.: 80116-201
09/2004

Adjustment 9

NESSY resistance measurement

Procedure

- Call up Test program 16, Adjustment 9.
- Connect an NE cable to the NE input receptacle on the ICC system.
- Connect the other end of the NE cable between 120 ohms of resistance.
- Set TP9 on the control board (slot J3) in such a way that a measurement value of 200 for the A/D converter is displayed in the AUTO CUT field and a resistance of 120 ohms is displayed in the AUTO COAG 1 field.
- Now exchange the terminating resistor for a resistance value of 40 ohms. Now verify the measurement at this resistance; a resistance of 40 ohms (tolerance 37...43 ohms) must be displayed in the AUTO COAG 1 field.

ICC 350 ICC 300				
AUTO CUT	AUTO COAG 1	AUTO COAG 2	AUTO BIPOLAR	
xxx	R üb		r	Standby

ICC 200		
AUTO CUT	AUTO COAG	
xxx	R üb	Standby

- R üb Contact resistance at the neutral electrode [Ω]
- xxx Analog measurement value of the contact resistance.

For resistance values outside the measurement accuracy, the display --- appears.

Adjustment 9

NESSY resistance measurement

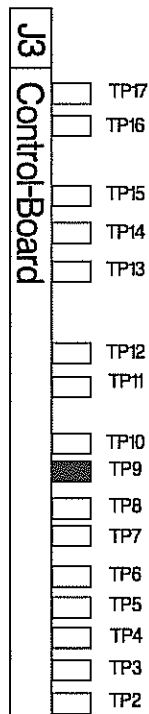
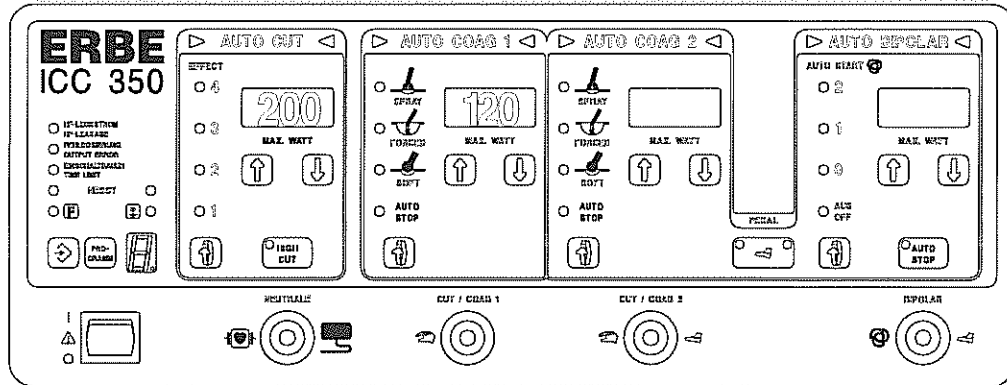

Art. No.: 80116-201
09/2004

Adjustment 10

Art. No.: 80116-201
09/2004

Adjustment 10

HF leakage current measurement

Procedure (This adjustment only applies to the ICC 350)

- Call up Test program 16, Adjustment 10.
- Connect the HF power meter (set to 350 ohms load resistance) between the active electrode of the CUT / COAG 2 (center) socket and the potential equalization.
- Jumper J3 must be plugged into the display board for this adjustment (earthed reference).
- Short together the NE-ERBE original adapter cable. Activate the ICC 350 using the blue footswitch pedal (AUTO COAG 1).
- Using the power setting in the AUTO COAG 1 field, set the leakage current flowing to ground to a value of 150 mA_{eff} (tolerance 131...169 mA) (use an HF effective current meter or set a power of 7.9 watts at a HF power meter with a load resistance of 350 ohms [tolerance 6.0...10 watts (from $P = I^2 \cdot R$ with $P = 7.9$ watts and $R = 350$ ohms is a current $I = 150$ mA)]).
- Set TP10 on the control board (slot J3) in such a way that the HF leakage alarm is thus displayed visually (the LED in the safety field flashes in the display indicates the value 50 in the Auto Cut field).
- Increase the leakage current by changing the power setting until an audible alarm is also emitted. This should occur at 300...350 mA (accordingly 31.5...43 watts on a HF power meter at the above setting).

ICC 350				
AUTO CUT	AUTO COAG 1	AUTO COAG 2	AUTO BIPOLAR	
xxx	ppp		HFL	Standby

- ppp Set SOFT COAG power which can be changed during activation.
- xxx Measurement value of the HF leakage current measurement.

Using the power setting in the AUTO COAG 1 field, set the HF leakage current flowing to ground at $I_{\text{eff}} = 150$ mA. This is not assigned for the ICC 200 and 300 since no HF leakage current monitor is available there.

Adjustment 10

HF leakage current measurement

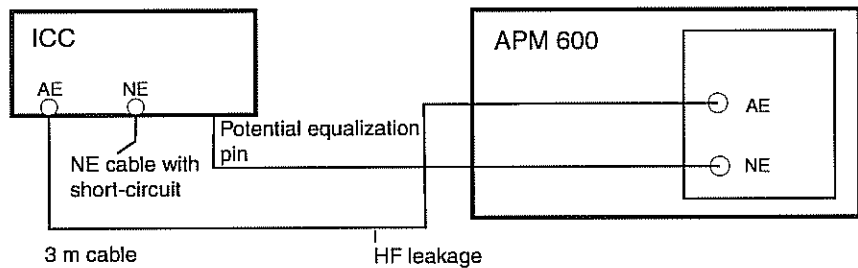
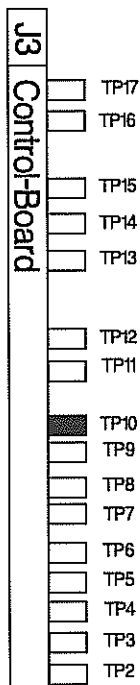
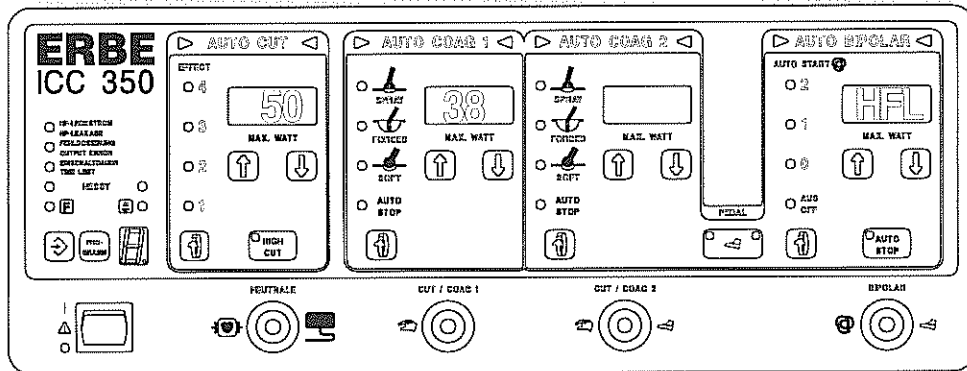

Art. No.: 80116-201
09/2004

Appendix 1

Art. No.: 80116-201
09 / 2004

Adjustment 11

Contact monitor

Procedure

- Call up Test program 16, Adjustment 11.
- At the BIPOLAR output of the ICC, the ERBE bipolar Testbox for the bipolar automatic starter (EE 20100-017) or appropriate fixed resistors (1.2 kOhm and 2.5 kOhm with a capacity of 15 watts as well as 18 kOhm, 1 watt) is connected via the EE bipolar original cable.
- With a resistance of 2.5 kOhm (socket 1–2), a value of 25 must be displayed in the AUTO CUT field. (Display = resistance divided by 100). The setting of the switch-on threshold with PT11 on the PCB control board (slot J3) proceeds in such a way that, at a load resistance of 2.5 kOhm, the display in the AUTO COAG 2 field changes from “OFF” to “ON”.
- Now the short-circuiting monitor is set by connecting a 6 ohm resistor (capacity = 0.5 watts) to the BIPOLAR outlet. Then, the display »rLo« appears on the AUTO COAG 1 display. Using TP12 on the PCB control board J3, the display is set to a measurement value of 100 in the AUTO CUT display.
- Testing the shutdown response: To do this, exit Test program 16 briefly by selecting Test program 0. The ICC operates in the normal mode. Switch on AUTO START 1. Set the bipolar power to 1 watt. The BIPOLAR outlet is connected to sockets 1 and 3 on the ERBE Testbox and thereby charged with 1.2 kOhm. The BIPOLAR generator must automatically be activated after the delay time. Now press pushbutton 1 on the Testbox. This raises the capacity resistance to 18 kOhm. The BIPOLAR generator must now shut down.
- This test must be repeated at the power settings 20 watts, 40 watts, 50 watts (or without AAMI standard up to 120 watts).

ICC 350 ICC 300				
AUTO CUT	AUTO COAG 1	AUTO COAG 2	AUTO BIPOLAR	
uuu	OFF		br	open output
rda	ON		br	loaded output
iii	rLo		br	loaded output

ICC 200		
AUTO CUT	AUTO COAG	
uuu	OFF	open output
rda	ON	loaded output

Adjustment 11

Contact monitor

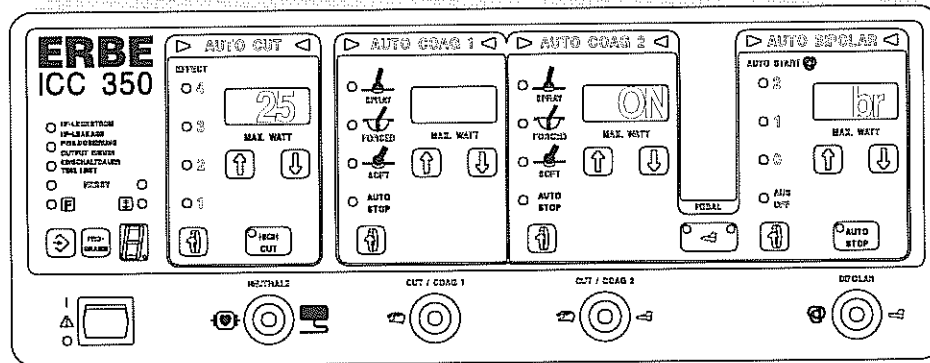

- uuu Standby measurement value of the contact monitor at a preset bipolar power of 10 watts
- rda Calculated contact resistance at activation [$\Omega/100$]
- iii Amplified output current at contact resistance $< 1 \text{ k}\Omega$
- rLo Display if resistance measured at activation $< 1 \text{ k}\Omega$

Adjustment 12

Art. No.: 80116-201
09/2004

Adjustment 12

Pulse/pause length ST output stage

Procedure

- Call up Test program 16, Adjustment 12.
- Measure actuation impulse TSI_STE at measuring point MP 3 on ST output stage (slot J6) with the oscilloscope (measuring point MP1 = GND).
- Using TP16, set this to a pulse length of 200 ns (± 50 ns).
 IMPORTANT! The pulse time is measured at average amplitude, i.e. at approx. 7.5 volts level.
 ATTENTION! The pulse is inverted.
- The repetition frequency at TP17 is set in such a way that the value 0 (tolerance 0...4) is displayed in the AUTO CUT field.
- Now exit the test program and return the ICC to normal operating condition.
- To check the performance, connect the HF output to the HF power meter, setting 500 ohms.
- Activate the ICC using the blue footswitch pedal at the SPRAY and FORCED normal settings. The power output in watts should correspond to the display in the AUTO COAG 2 field.
- Check whether the maximum emitted output power with SPRAY and FORCED is within the tolerance limits ($120\text{ W} \pm 15\%$). If necessary, conform the pulse length to the PCB control board using TP16. TP17 must no longer be changed.

ICC 350 ICC 300				
AUTO CUT	AUTO COAG 1	AUTO COAG 2	AUTO BIPOLAR	
xxx	ppp		tSt	Standby

ICC 200		
AUTO CUT	AUTO COAG	
xxx	tSt	Standby

- ppp Set AUTO COAG 2 FORCED power
- xxx Difference = Set frequency minus actual frequency

Adjustment 12

Pulse/pause length ST output stage

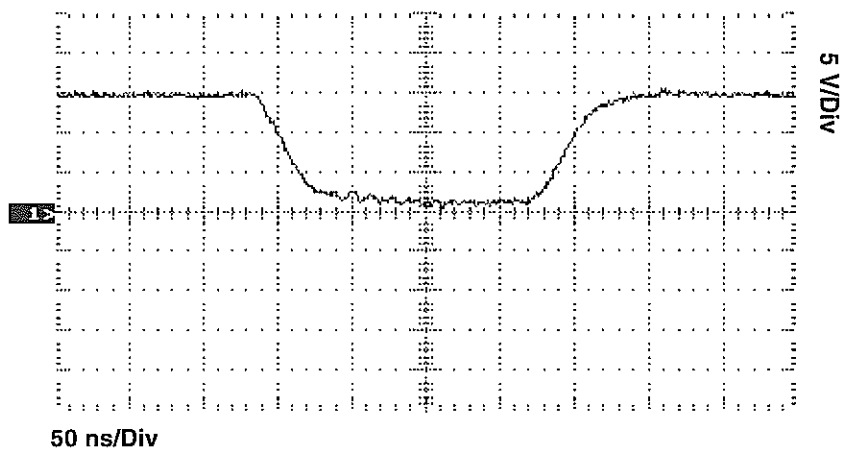
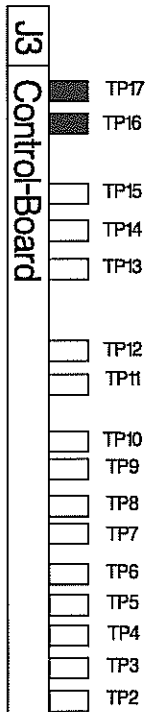
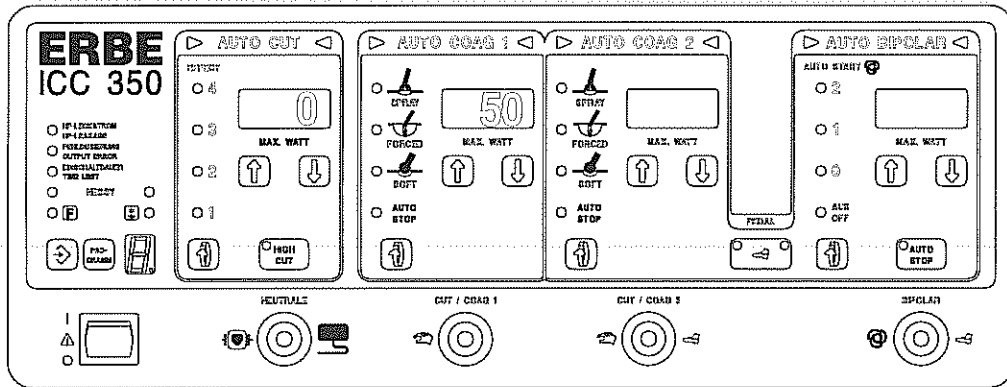

Fig. : Transistor switching pulse ST output stage

Adjustment 13

Art. No.: 80116-201
08/2004

Adjustment 13

LF leakage current monitor (ICC 350 only)

Procedure

- Call up Test program 16, Adjustment 13.
 - Set the jumper to the “capacitance grounded” operating mode (place jumper J3 on display board).
 - Perform adjustment using ERBE TESTBOX 2 or another 50 Hz sine-wave current source.
 - Between the neutral electrode output and the potential equalization, feed a 50 Hz sine-wave current of 45 μA (see Figure).
 - Using TP1 on the motherboard, set the leakage current monitor in such a way that the display in the AUTO CUT field changes just from 0 to 1 at 45 μA_{eff}
- Reset jumper to previous condition.

ICC 350				
AUTO CUT	AUTO COAG 1	AUTO COAG 2	AUTO BIPOLAR	
x			1 nF	Standby

- x x = 0 for LF leakage current < 50 μA
 x = 1 for LF leakage current > 50 μA .

For adjustment, the test current must be fed according to the instructions.

Adjustment 13 is not assigned on the ICC 300 and ICC 200.

Measurement setup

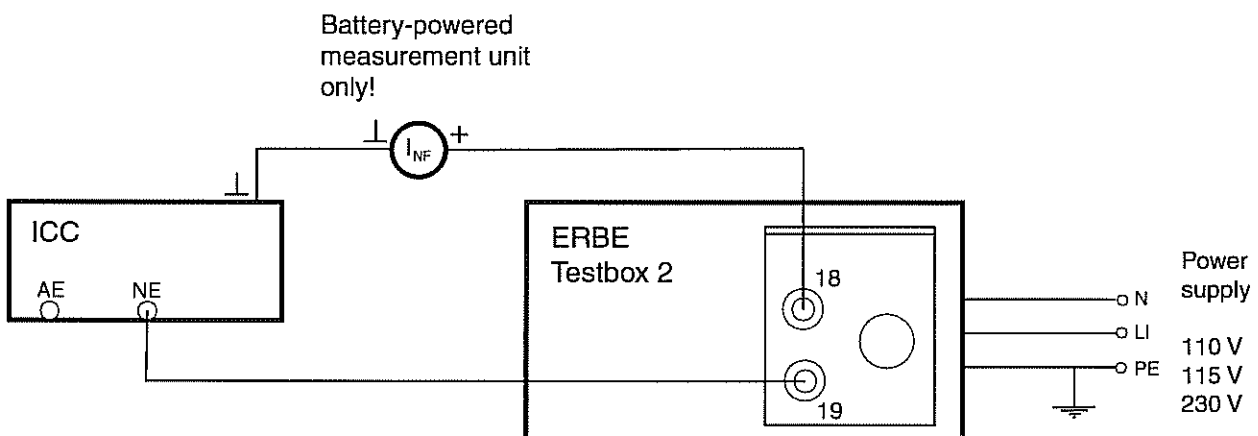

Adjustment 13

LF leakage current monitor

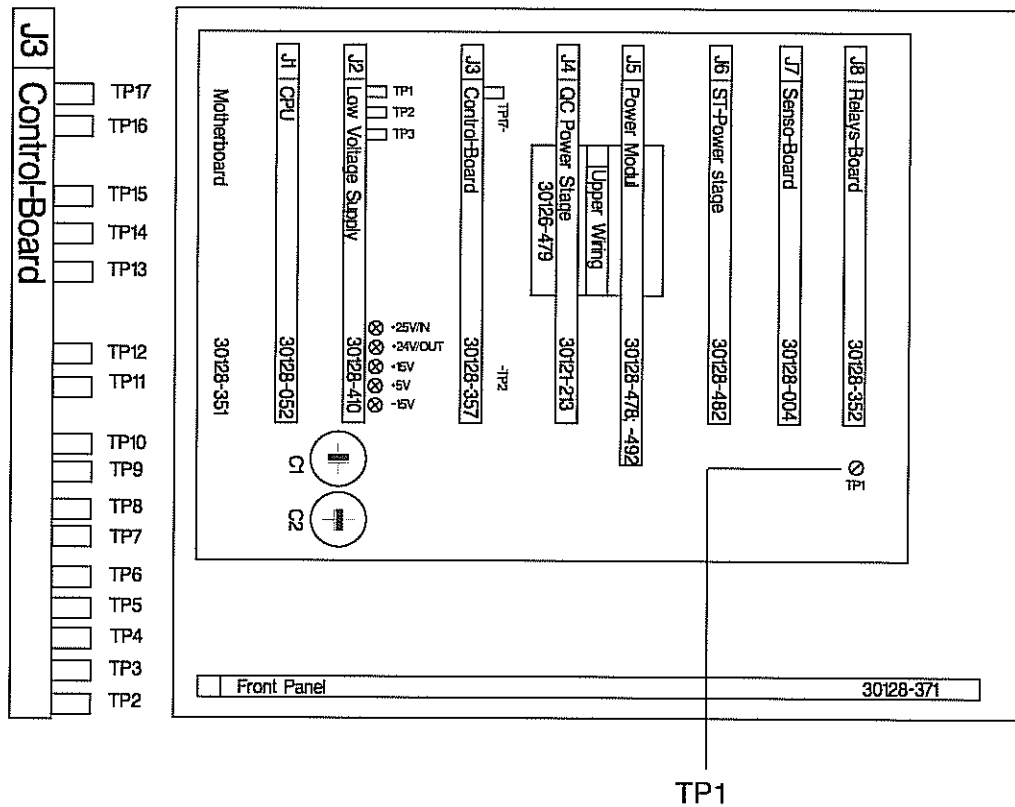
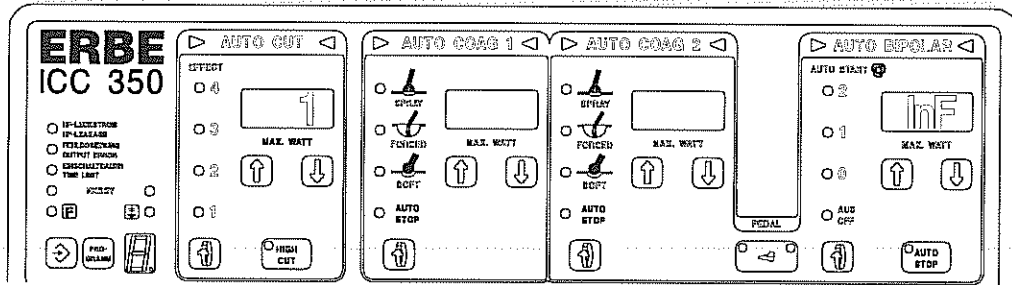

Art. No.: 80116-201
08/2004

Adjustment of
ICC 350 ZMK Neurotest
Version V2.00
ICC 350 TUR Neurotest
Version V2.00

Adjustment of Neurotest board

Neurotest board EE 30128-070

Jumper JP4 on the front panel is used to activate the display of the feedback frequency of output current measurement and display of the feedback frequency of the remote control are activated.

ATTENTION

On the ZMK version, there is a display only during activation and if the Neurotest circuit is closed. On the TUR version there is a display as soon as the NT LED lights up on the remote control.

AUTO CUT	AUTO COAG 1	AUTO COAG 2	AUTO BIPOLAR
SPH	Intensity no.	Frequency measurement	Current measurement

SPH: The Neurotest program is activated.

Intensity no. Set intensity number is 1...5. It corresponds to the intensity number which has been set on the remote control.

Frequency measurement Measurement of feedback frequency of the remote control.

Current measurement Measurement of feedback frequency of the output current measurement.

Setting the feedback frequency of output current measurement

(trimming potentiometer TP 1: Setting the feedback frequency)

The Neurotest board is isolated and actuated via optocoupler. The feedback frequency of the output current measurement also takes place via an optocoupler. The output current pulse is converted into a frequency. This frequency can be measured at test point MP7. Test point MP6 is reference ground. Test points MP6 and MP7 relate to the electronic circuitry of the ICC unit. Without activation, the feedback frequency is 0 Hz. After the pulse time, the feedback frequency is only available at MP7 for a brief period.

Test setup

At the Neurotest output, connect up a test resistor of 1 kOhm, 0.5 W and 1%. On the TUR version, the Neurotest output is between the neutral electrode and the CUT/COAG 2 output. The TUR version is activated with the yellow pedal of the dual-pedal footswitch. On the ZMK version the Neurotest output is between the neutral electrode and the Neurotest output. The ZMK version is activated with the ZMK fingerswitch.

The setting is performed at intensity 3. For this setting the set feedback frequency must be adjusted to 73. If the electronic fuse trips, the display of feedback frequency is approx. 40.

Adjustment of Neurotest board

Neurotest board EE 30128-070

AUTO CUT	AUTO COAG 1	AUTO COAG 2	AUTO BIPOLAR		
			Set	Min.	Max.
			Current measurement		
SPH	1		52	42	75
SPH	2		91	81	100
SPH	3 (Set value 73)		73	63	83
SPH	4		64	54	74
SPH	5		59	49	69

ATTENTION!

Don't forget to remove the jumper!

Check the fusible link for correct rating

F1: Microfuse FF 1/16 /125 V (62 mA), Wickmann Type 19278K

High-voltage test

The high-voltage test is conducted according to the specifications in the test record.

Testing the activation signals

The TUR version is activated with the yellow pedal of the double-pedal footswitch. The ZMK version is activated with the ZMK fingerswitch.

Performance test on the constant-current circuit

A test resistor of 1k, 0.5W and 1% and a rotary potentiometer of 50k 0.3W are connected in series at the Neurotest output. Measure the square-wave voltage on the 1k test resistor. (1mA corresponds to 1V) The tolerance range of output currents is +25% to -25%. Larger deviations generate an output error display.

Adjustment of Neurotest board

Neurotest board EE 30128-070

Square-wave output peak current	Control range of constant-current source
SPH 1: 5 mA	0R...approx. 20 kOhm
SPH 2: 10 mA	0R...approx. 10 kOhm
SPH 3: 15 mA	0R...approx. 6 kOhm
SPH 4: 20 mA	0R...approx. 5 kOhm
SPH 5: 25 mA	0R...approx. 4 kOhm

Testing the constant-current source

Slowly set the rotary potentiometer higher from 0R. At a total resistance of approx. 6 kOhm, there is an output error display. At approx. 6 kOhm, the output current is constant.

Performance test on output error monitoring.

- At the Neurotest output connect a test resistor of 1 kOhm, 0.5 W and 1%.
- Set SPH 1.
- Activate the unit. When the circuit is interrupted there will be an output error message.

Performance test on the electronic fuse

The output current is monitored constantly. In the event of an excess dose, the electronic fuse trips and via longitudinal transistor T3 switches off the constant-current source supply voltage. The electronic fuse is monitored in the interval between the pulses. If the electronic fuse has tripped, this is indicated by the message ERROR 90 or ERROR 84.

- To trip the electronic fuse: Activate the Neurotest function and briefly connect test point MP9 to MP2. The electronic fuse should respond. The microfuse must not trip.

General information about the self-check

Before activation, or when setting the intensity on the remote control, there is a check on the electronic fuse in two steps.

1. Briefly switch on transistor T1 and thus trip the electronic fuse. There is a message ERROR 90 or ERROR 84 if the electronic fuse has tripped.
2. Briefly switch on transistor T2 and thus reset the electronic fuse. There is a message if the electronic fuse has not been reset.

Adjustment of Neurotest board

Neurotest board EE 30128-070

Activation test

Activation of the HF LED on the remote control takes place at intensity setting 0 using the rotary switch on PC board EE 30121-442. At an intensity setting of 1 to 5 the NT LED is actuated by the CPU and the HF LED must not light up. On the TUR version a check must be performed as to whether activation of the HF is inhibited when intensity of 1 ... 5 is set. On the ZMK version, activation of the HF is possible even if intensity 1 ... 5 has been set.

Adjustment of remote control for Neurotest

Art. No.: 80116-201
09/2004

Adjustment of remote control for Neurotest

Neurotest board EE 30121-442

Setting the remote control for Neurotest board EE 30121-442

Jumper JP4 on the front panel is used to activate the display of the feedback frequency of output current measurement and display of the feedback frequency of the remote control are activated.

AUTO CUT	AUTO COAG 1	AUTO COAG 2	AUTO BIPOLAR
SPH	Intensity no.	Frequency measurement	Current measurement

ATTENTION!

On the ZMK version, there is a display only during activation and if the Neurotest circuit is closed. On the TUR version there is a display as soon as the NT LED lights up on the remote control.

- SPH: The Neurotest program is activated.
- Intensity no. Set intensity number is 1...5. Corresponds to the intensity number which has been set on the remote control.
- Frequency measurement Measurement of feedback frequency of the remote control.
- Current measurement Measurement of feedback frequency of the output current measurement.

Setting the feedback frequency for intensity setting

(trimming potentiometer TP 1: Setting feedback frequency)

The intensity setting is converted to a frequency. This frequency can be measured at Pin 1 AD654 on IC1. Test point MP6 is reference ground. Frequency is measured using a frequency meter. The setting takes place at intensity 5 - for this setting the set feedback frequency is adjusted to 38.0 Hz (-0.5 Hz, +0.0 Hz) on the frequency meter.

AUTO CUT	AUTO COAG 1	AUTO COAG 2			AUTO BIPOLAR		
		Frequency measurement			Currency [Hz]		
		Set	Min.	Max.	Set	Min.	Max.
SPH	1	7	5	10	200	180	215
SPH	2	14	11	20	105	80	120
SPH	3 (Set value 73)	24	21	28	62	57	67
SPH	4	32	29	36	45	43	49
SPH	5	38	37	60	38	37	40

Adjustment of remote control for Neurotest

Neurotest board EE 30121-442

ATTENTION!

Don't forget to remove the jumper.

Setting the feedback frequency for intensity adjustment can also be performed without the ICC unit by supplying +15 V to the remote control and measuring the feedback frequency using the frequency meter.

High-voltage test

The high-voltage test is performed using the specifications in the test record.

Testing the LED display

Actuation of the HF LED is conducted at intensity setting 0 using the rotary switch PC board on EE 30121-442. At an intensity setting of 1 to 5, the NT LED is actuated by the CPU and the HF LED must not light up. The NT LED only lights up when the feedback frequency is in the valid range. Check intensity setting 1...5.

Adjustment of activation and instrument detection

Adjustment of activation and instrument detection

MIC board 30128-200 (V4.0)

List of units involved

ICC 350 MIC-MIEN	V4.0	EE 10128-080
ICC 350 MIC-MIEN-DOKU	V4.0	EE 10128-081
ICC 350 MIC-MIEN F	V4.0	EE 10128-082
ICC 350 MIC-MIEN Int.	V4.0	EE 10128-083
ICC 350 MIC-MIEN Int UL	V4.0	EE 10128-215
ICC 350 MIC-MIEN Japan, 100V	V4.0	EE 10128-310

Identification of the trimming potentiometers:

Trimming potentiometer TP 1: setting the instrument detection.

Trimming potentiometer TP 2: setting the activation detection.

Valid instrument number

Program no.	Instrument	Resistance	Instrument no.
12 MIC	TEM instrument EE 20191-275	10 Ohm \pm 1 %; 0,2 W	1
13 MIEN	Probe EE 20191-356	30 Ohm \pm 1 %; 0,2 W	2
13 MIEN	Probe EE 20191-357	30 Ohm \pm 1 %; 0,2 W	2

The probes of no. 2 are only suitable for coagulation and CUT remains inhibited.

Display of instrument number

AUTO CUT	AUTO COAG 1	AUTO COAG 2	AUTO BIPOLAR
Inr.	Nr.	p3	nd

Inr. Instrument recognized

No. Instrument number

p3 Power setting AUTO COAG 2

–nd Compressed air valve for needle control is actuated (only MIC)

nd Compressed air valve for needle control is not actuated (only MIC)

Adjustment of activation and instrument detection

MIC board 30128-200

Setting the instrument detection

- The setting takes place in program 12 MIC.
- Connect a resistor of 51 R, $\pm 1\%$ and 0.2W to the test line.

ATTENTION!

The original ERBE TEM connecting cable EE 20192-086 has a cable impedance of 1 Ohm per cable, which produces a series resistance of 2 Ohms for the instrument detection. In the line to and from the unit the instrument test line must have a series resistance of < 0.5 Ohm. Since on the V4.00 version only the TEM instrument no. 1 and MIEN probe no. 1 are connected up, it is sufficient to perform the balance only for these instruments.

With jumper JP4 on the front panel the measurement display is activated.

Measurement display

AUTO CUT	AUTO COAG 1		
I measurement	I no.		

I-measurement Measurement of instrument detection 0...255

I-No. Instrument number

Using trimming potentiometer TP 1, set I measurement to 52 (resistance of 51 R $\pm 1\%$; 0.2 W).

Testing the instrument detection

Detection resistance	Instrument no.	Valid range
0 R	0	0...2
10 R	1	3...20
30 R	2	21...45
51 R	3	set value 52
62 R	4	70...91

Adjustment of activation and instrument detection

MIC board 30128-200

Setting of activation detection

Set the trimming potentiometer TP 2 to approximately the center position.

ATTENTION!

Never forget to remove jumper JP4.

Test instructions for program 12 MIC

- Assignment of MIC output socket for the MIC program:
 - Pin 1: NE 1
 - Pin 2: NE 2 not assigned
 - Pin 3: CUT cutting function
 - Pin 4: Instrument detection between Pin 1 and Pin 4
 - Pin 5: Activation detection between Pin 1 and Pin 5
- Set and test instrument detection and activation detection:

Test instrument detection together with the TEM instrument EE 20191-275 and connecting cable EE 20192-086 in the MIC program.
- Connect up the compressed air supply:

The MIC output socket is active in the MIC program. Connect up to the compressed air supply (max. 5 bar). Connect up 10 Ohm detection resistor corresponding to TEM instrument no. 1.
- Test CUT function:

The CUT function is activated with the yellow footswitch.

MIC socket	AUTO CUT	APM	P [Watt]
NE1 CUT	Effect 3 40 W	500 Ohm	40 ± 15 %

ATTENTION!

The measuring system will be damaged beyond repair if the HF lines are connected up to the APM incorrectly.

Adjustment of activation and instrument detection

MIC board 30128-200

The output error display is activated at 40 W and 500 Ohm. Activation of the BIPOLAR CUT function is also possible without the neutral electrode.

- Compressed air control

At instrument 1 the compressed air valve is opened during CUT activation. The compressed air valve controls the needle of the TEM instrument. After activation the needle reset time elapses. After needle reset time has elapsed the compressed air valve closes and the needle is reset. Needle reset time is indicated in test program 23. Check the compressed air valve to make sure that it operates properly and to ensure there are no leaks.

- Check monopolar coagulation

Activation of the SOFT function and the FORCED function is performed using the blue footswitch.

MIC socket	AUTO COAG 2	APM	P [Watt]
NE1 ICC 350 NE Electrode	SOFT 120 Watt	75 Ohm	120 ± 15 %
	FORCED 60 Watt	350 Ohm	60 ± 15 %

Test instructions for program 13 MIEN

- Assignment of the MIC output socket for the MIEN program

Pin 1: NE 1 bipolar

Pin 2: CUT and COAG function bipolar. (MIEN protective circuit).

Pin 3: not assigned

Pin 4: Instrument detection between Pin 1 and Pin 4

Pin 5: Activation detection between Pin 1 and Pin 5

- Test instrument detection.

Test instrument detection together with the MIEN probe EE 20191-305/308 and handlepiece EE 20191-306 in the MIEN program.

- Test bipolar CUT function

The CUT function is activated using the yellow footswitch.

ATTENTION!

The measuring system will be damaged beyond repair if the HF lines are connected up to the APM incorrectly.

Adjustment of activation and instrument detection

MIC board 30128-200

MIC socket	AUTO COAG 2	APM	P [Watt]
NE1 CUT	Effect 3 15 Watt	500 Ohm	15 ± 3 (W)

The output error display is activated at 40 W and 500 Ohms. Activation of the bipolar CUT function is also possible without the neutral electrode.

- Test bipolar SOFT coagulation
The SOFT function is activated with the blue footswitch.

MIC socket	AUTO COAG 2	APM	P [Watt]
NE1 CUT	SOFT 15 Watt	500 Ohm No-load voltage $84 \pm 5 V_p$	7 ± 2 (W)

- Test the protective circuit with test program 18
In the event of an error, the protective circuit in the MIEN program prevents an overdose of HF voltage and HF current. If the output current is too high, the fusible link in the protective circuit trips. The test checks whether the correct fuse is inserted. The manufacturer of the fuse and the fuse rating can be found in the parts list.
- Testing the voltage limitation with no load
Activate test program 18.
In the AUTO CUT display panel the set value of HF output voltage is displayed. With the CUT “Up/Down” buttons, the HF output voltage can be adjusted in the range from 260V_p to 500 V_p (±50V_p).
Connect oscilloscope to the MIC output socket NE1 and CUT.
The highest HF peak voltage at the AUTO CUT Effect 3 (15 W) setting is 340 V_p. At this voltage the protective circuit must not yet impose any limitation.
The protective circuit limits the output voltage from 360 V_p upward. Range in which the limitation must be activated: 360–450 V_p.
At the setting of 499 V_p the fuse will not trip and the operability of the protective circuit remains intact.

ATTENTION!

As soon as the voltage limitation is activated, current flows through the protective diodes and the diodes heat up. The duration of the test from the moment of voltage limitation must not exceed 5 seconds or else the protective diodes break down and the circuit will have to be repaired.

Adjustment of activation and instrument detection

MIC board 30128-200

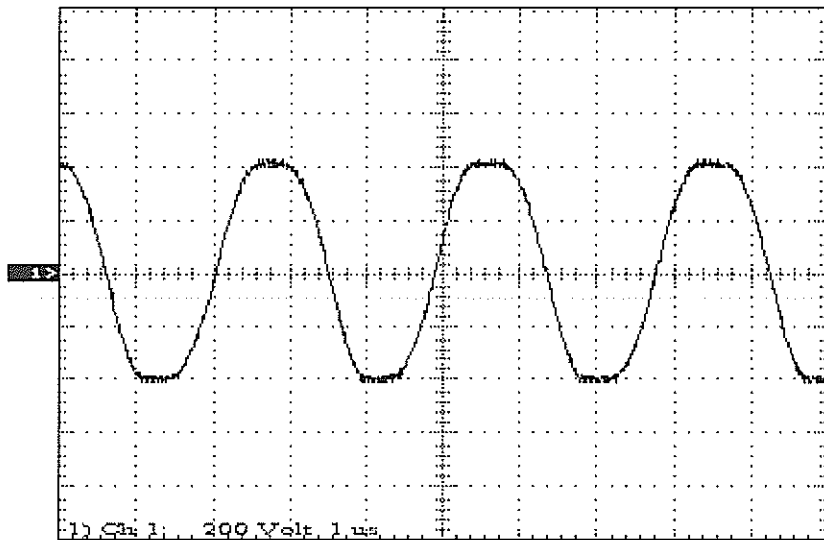

Voltage limitation at setting of 415 V_p.

ATTENTION! The test duration must not exceed 5 seconds!

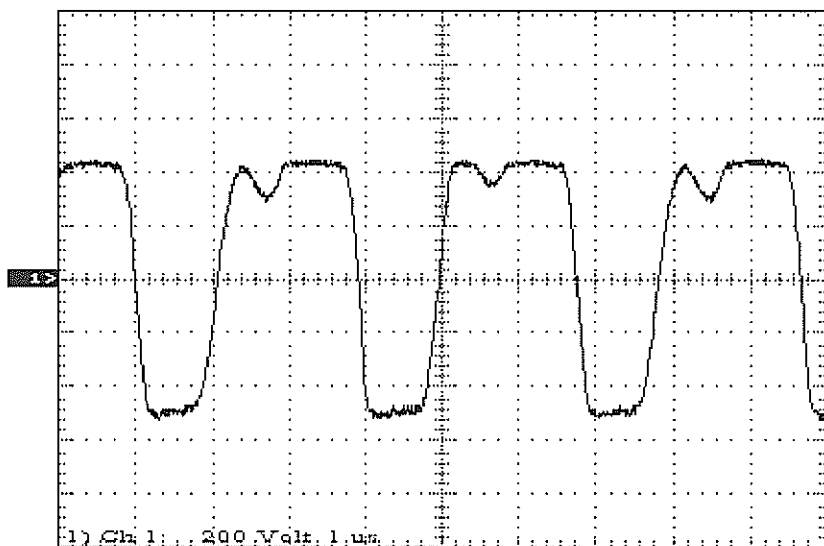

Voltage limitation at setting of 499 V_p.

ATTENTION! The test duration must not exceed 5 seconds!

Test program no. 17

Brightness setting of the 7-segment displays

General description

Using this program, you can adapt the brightness of the 7-segment displays in 10 stages to the lighting conditions of the room.

After starting the test program, you will see the following display:

AUTO CUT	AUTO COAG 1	AUTO COAG 2	AUTO BIPOLAR
Int	xx

- Int Intensity (brightness) of the displays
- xx Present intensity, adjustable from 1...10.

You can make the intensity brighter using the “Up” (8) key or darker using the “Down” (9) key.

After termination of the test program, store the brightness setting with key 3.

Test program no. 23

Changing the delay time with AUTO START

General description

Using this program, you can change the specifications for the delay time when activating AUTO START. The delay time is the time which passes after the forceps contacted the tissue and the HF generator is actuated.

So that the operating surgeon can know whether the forceps have contacted the tissue, the AUTO BIPO-LAR activation display (blue triangle in the AUTO-BIPOLAR field) switches on at contact. Then the delay time starts. After the delay time has passed, the HF generator and the activation tone are switched on.

In case of error in the memory medium, the following basic settings have been preset:

ICC 350 and ICC 300: AUTO START 0: 0 seconds,
 AUTO START 1: 0.5 seconds,
 AUTO START 2: 1 second;
ICC 200: AUTO START: 0.5 seconds.

After starting Test program 23, you will see the following display:

AUTO CUT	AUTO COAG 1	AUTO COAG 2	AUTO BIPOLAR
SEt	Up		tt.t

Time setting

Possible from 0.1 to 10 seconds in the following time steps:

from 0.1 to 2.0 seconds in 0.1 seconds steps

from 2.0 to 10.0 seconds in 0.5 seconds steps.

Procedure for ICC 350

AUTO START	Setting range
0	0 greater than/equal to t greater than/equal to 1
1	1 greater than/equal to t greater than/equal to 2
2	2 greater than/equal to t greater than/equal to 10 seconds

You can set and store the delay time for every user-specific program 0 to 9 and for every AUTO-START time (0, 1 and 2).

Since the AUTO-START time 0 can be no longer than AUTO-START time 1, it is best to proceed from the longest time for AUTO START 2 and then set the times for AUTO START 1 and AUTO START 0.

Test program no. 23

Changing the delay time for AUTO START

Procedure for ICC 200

AUTO CUT	AUTO COAG 1	AUTO COAG 2	AUTO BIPOLAR
SEt	Up		tt.t

For the AUTO START function, you can set and store a delay time.

1. Using the “Up” or “Down” key Set the required time
2. Using key 3 The set values are stored and the test program is exited.

Chapter 2

ERROR list

ERROR list V 4.X

ERBOTOM ICC 350 (V4.0, V2.0), ICC 300 (V3.0), ICC 200 (V2.0)

Automatic error detection, indication and documentation

ERBOTOM ICC series high-frequency surgical units are equipped with a device for automatic error detection, indication and documentation (ERROR monitor).

Error detection, indication, documentation

For ERBOTOM ICC series equipment as of software version 2.0 / 4.0, the ERROR monitor can, depending on the type of equipment and its outfit, detect up to 91 currently occurring errors (ERROR) and indicate them on the display.

Error numbers (ERROR nos.) are assigned to the various errors. If an error is detected, it is immediately reported. The error report is both visual and audible.

The error numbers of detected errors are automatically stored chronologically. Since only 10 memory locations are available, only the last 10 error messages are displayed. If the same error is detected several times in a row, the corresponding error number is then saved only once in consideration of the limited number of available memory locations. The error numbers documented in memory can be displayed via Test program 2 and deleted.

Troubleshooting for ICC family equipment

The ICC unit family is equipped with an error detection system which detects and stores the last 10 errors detected in an ERROR list. This error memory can be called up via Test program no. 2. The user should thus be capable of localizing errors himself and deciding whether this is an operating error or an error in the accessories, which he can possibly eliminate himself, or whether it is necessary to make use of the technical service.

If there is a complete failure of the system and no display is visible, the power supply may have been interrupted or the voltage supply inside the unit is defective. In such a case, first check whether the outlet used is live or a fuse in the house power supply has been tripped (Does a different unit function at this outlet?). If the outlet used is live, check the powerline to the unit and replace if necessary. The equipment fuses on the rear panel should also be checked and replaced if necessary.

ATTENTION!

Only use original fuses of the same specification.

If these efforts bring no results, there is probably an error within the unit. You should then contact the technical service.

For a malfunction with a properly functioning display but with no indication of an ERROR number in the display, the error may be located in defective accessories. It is possible, for example, that there may be a defect in the fingerswitch or footswitch, or a disruption in the associated connecting cable. The cause of the error may be determined by exchanging the accessories used.

To determine other causes of errors, an ERROR number in the unit display indicates the course of further action according to the following table.

ERROR no. 1-13

Error no.	Designation and remedies
1	No HF voltage present at the HF voltage sensor. Error in the HF generator. <i>Short circuit in accessories: Replace accessories.</i> <i>Other equipment error: Technical Service.</i>
2	HF output voltage too high, error in the HF generator. <i>Equipment error: Technical Service.</i>
3	The switched-mode power supply unit supplies no voltage during activation, error in the switched-mode power supply unit. <i>Equipment error: Technical Service.</i>
4	The switched-mode power supply unit supplies too high a voltage upon activation of the ST generator, error in the switched-mode power supply unit. <i>Equipment error: Technical Service.</i>
5	LF leakage current is > 50 μ A and flows into the unit via the neutral electrode. <i>Check positioning of the patient, whether there is contact with the infusion stand or the like.</i> <i>Other defective equipment connected to the patient?</i> <i>Are the potential equalization and grounded conductor OK?</i>
6	During the activation phase, the safety shutoff feature output reports "ON". <i>Equipment error: Technical Service.</i>
7	During the activation phase, the safety shutoff feature output reports "OFF". <i>Equipment error: Technical Service.</i>
8	not assigned
9	Maximum continuous time limit exceeded. <i>Only activate the unit if necessary. The time limit monitor is a safety feature and should generally only be increased with a strict indication using Test program 10 in the setup.</i>
10	Error during activation of the AUTO CUT, no valid front panel setting. <i>Confirm control panel by pressing a key. Select required power setting.</i>
11	Error during activation of AUTO COAG 1 or AUTO COAG 2, no valid front panel setting. <i>Confirm control panel by pressing a key. Select required power setting.</i>
12	Error during activation of AUTO BIPOLAR, no valid front panel setting. <i>Confirm control panel by pressing a key. Select required power setting.</i>
13	Error during activation of AUTO CUT: - NESSY: measured NE impedance is > 120 ohms. - Using Test program no. 7, split electrodes were set: NE impedance < 10 ohms. <i>Check NE cable.</i> <i>Check NE contact surface: Short circuit? Is NE stuck to metal?</i> <i>If necessary, set required neutral electrode using Test program 7.</i>

ERROR no. 14-22

Error no.	Designation and remedies
14	(not assigned)
15	(not assigned)
16	(not assigned)
17	Error during activation. HF leakage current > 300 mA. <i>Check position of the patient: Contact points with infusion stand or the like.</i> <i>Otherwise equipment defect: Technical Service.</i>
18	Error during activation. 150 mA < HF leakage current < 300 mA. <i>Check position of the patient . Eliminate contact points with infusion stand or the like.</i> <i>Otherwise equipment defect: Technical Service.</i>
19	Error during activation of AUTO CUT and AUTO COAG: NESSY current density error. <i>Check NE cable for interruption.</i> <i>Check contact surface and application point of the NE.</i> <i>Otherwise equipment defect: Technical Service.</i>
20	For AUTO CUT and AUTO COAG: NESSY current symmetry error. Variably high current flowing into the joint phases of the NE. <i>Check cable to the NE (interruption).</i> <i>Check NE contact surface.</i>
21	Current symmetry error. <i>See ERROR 20.</i>
22	When switching on the power, AUTO CUT is switched on. <i>Activate unit only after switching on power. Check fingerswitch and footswitch as to whether a key or pedal is stuck or the switch is defective.</i> <i>Otherwise equipment defect: Technical Service.</i>

Art. No.: 60T16-201
09/2004

Error no.	Designation and remedies
23	Switch on the power, AUTO COAG 1 is switched on. <i>Activate unit only after switching on power. Check fingerswitch and footswitch as to whether key or pedal is stuck or switch is defective.</i> <i>Otherwise equipment defect: Technical Service.</i>
24	When switching on the power, AUTO COAG 2 is switched on. <i>Activate unit only after switching on power. Check fingerswitch and footswitch as to whether key or pedal is stuck or switch is defective.</i> <i>Otherwise equipment defect: Technical Service.</i>
25	When switching on the power, AUTO BIPOLAR is switched on by footswitch. <i>Activate unit only after switching on power. Check footswitch as to whether key or pedal is stuck or switch is defective.</i> <i>Otherwise equipment defect: Technical Service.</i>
26	Contact is detected when switching on the power. Contact monitor is active. <i>Check the forceps connecting cable or check forceps for a short circuit. The forceps tips are touching or lying on a conductive base: Isolate forceps.</i> <i>Otherwise equipment defect: Technical Service.</i>
27	Overheating! Internal unit temperature > 100°C. Permissible output power is reduced. Unit generated max. power for a longer period of time. <i>Allow unit to cool down.</i> <i>Coagulation electrode too large?</i> <i>Short circuit or error in accessories?</i>
28	Activation signal for the blue footswitch button already on. <i>Is the blue footswitch button depressed? Is the button or switch stuck? If necessary, briefly unplug the footswitch as a test.</i> <i>First preselect footswitch on the front panel and then switch on.</i>
29	For Spanish version: During activation, a further activation signal is detected. <i>Double activation not permissible.</i>
30	Mismatch! Over a time period > 5 sec , the load resistance is < 50 ohms. Check accessories for short circuit.
31	Mismatch! The output power is > 100 watts. During activation, the load resistance remains constant and < 300 ohms. After a prescribed time, ERROR 31 appears. <i>Check accessories for short circuit.</i>
32	Multiple activation detected. <i>No simultaneous activation via several sources.</i> <i>If unsuccessful, unit is then defective. Technical Service.</i>
33	At the end of activation, a new activation signal immediately appears. <i>No simultaneous activation via several sources.</i>

ERROR no. 34-48

Error no.	Designation and remedies
34	Multiple activation detected during AUTO BIPOLAR . <i>No simultaneous activation via several sources.</i>
35	There is already a new activation signal during AUTO BIPOLAR with AUTO STOP or AUTO START. <i>No simultaneous activation via several sources.</i>
36	When pressing the BIPOLAR AUTO START key, there is already an AUTO START signal . The contact monitor is activated. <i>see ERROR no. 26.</i> <i>Otherwise equipment defect: Technical Service.</i>
37	Error during activation. <i>At the point in time of activation, the power supply unit voltage has not yet dissipated. Power supply discharge faulty. Equipment defect: Technical Service.</i>
38	During AUTO START activation, the contact resistance is < 6 ohms. <i>Inspection of the forceps and supply cable for short circuit.</i>
39	not assigned
40	Monitor ST generator time control. Output error: ST time control for FORCE and SPRAY. <i>Actual value > set value plus 20%: Technical Service necessary.</i>
41	Like Error 40, but <i>Actual value < set value minus 20%: Technical Service necessary.</i>
42	Like Error 41, but <i>Actual value > set value minus 40%: Technical Service necessary.</i>
43	Monitor of ST generator time control. <i>Output error. No frequency feedback: Equipment defect: Technical Service.</i>
44	Monitor of the ST generator output voltage. <i>Output error: Equipment defect: Technical Service.</i>
45	HF generator error during self-check. <i>HF output voltage too low: Equipment defect: Technical Service.</i>
46	Self-check. <i>Error within the permissible limits during comparison of the power supply unit voltage with the HF output voltage. Equipment defect: Technical Service.</i>
47	HF generator error during self-check. <i>Like Error 46, but error outside permissible limits.</i> <i>Equipment defect: Technical Service.</i>
48	Patient current. <i>No signal from the output current monitor.</i> <i>Equipment defect: Technical Service.</i>

Error no.	Designation and remedies
49	not assigned
50 to 70	A key on the front panel is depressed. <i>Operating field key is depressed or defective during the power start-up phase. If it cannot be corrected, then equipment defect: Technical Service.</i>
71	Interface error for ICC 350 DOKU: Start or stop bit error or number of bits incorrect. <i>Equipment defect: Technical Service.</i>
72	Interface error for ICC 350 DOKU: Signal in receiving register has not been read out. <i>Equipment defect: Technical Service.</i>
73	Interface error for ICC 350 DOKU: Parity sign placed incorrectly. <i>Equipment defect: Technical Service.</i>
74	Interface error for ICC 350 DOKU: No connection to PC available. <i>Equipment defect: Technical Service.</i>
75	Interface error for ICC 350 DOKU: Sign stays in transmitter buffer. SIO module not transmitting. <i>Equipment defect: Technical Service.</i>
76	Interface error for ICC 350 DOKU: Interface storage takes too long; hard disk is too slow. <i>Equipment defect: Technical Service.</i>
77 to 79	not assigned
80	ICC 350 NEUROTEST: No valid frequency for the 5-stage intensity setting. <i>Replace remote control.</i> <i>Otherwise equipment defect: Technical Service.</i>
81	ICC 350 NEUROTEST: The intensity setting was set to 0 during activation. <i>Do not set anything during activation.</i> <i>Otherwise equipment defect: Technical Service.</i>
82	ICC 350 NEUROTEST: NESSY measurement: NE impedance > 120 ohms. <i>Test the neutral electrode and supply line or position of the NE on the patient.</i> <i>Otherwise equipment defect: Technical Service.</i>

ERROR no. 83-91

Error no.	Designation and remedies
83	ICC 350 NEUROTEST: Output current too high, but still within the permissible limits. <i>Equipment defect: Technical Service.</i>
84	ICC 350 NEUROTEST: Output current too high; outside permissible limits. <i>Equipment defect: Technical Service.</i>
85	ICC 350 NEUROTEST: No output current. Interruption of the circuit or failure of the frequency feedback system. <i>Check the neurotest cable supply lines or the handle, NE and cable and replace if necessary.</i> <i>Otherwise equipment defect: Technical Service.</i>
86	ICC 350 NEUROTEST: Output current too low, but within the permissible limits. <i>Check the neurotest cable supply lines, or the handle, NE and cable, and replace if necessary.</i> <i>Otherwise equipment defect: Technical Service.</i>
87	ICC 350 NEUROTEST: Output current too low; current is below the permissible limit. <i>Check neurotest cable.</i> <i>Otherwise equipment defect: Technical Service.</i>
88	ICC 350 NEUROTEST: Max. time limit has run out. The time limit monitor is a safety measure. <i>Only activate unit if necessary.</i>
89	ICC 350 NEUROTEST: When switching on the power, already a neurotest activation signal. <i>Equipment defect: Technical Service.</i>
90	ICC 350 NEUROTEST: Electronic fuse triggered or frequency feedback system has failed. <i>Equipment defect: Technical Service.</i>
91	ICC 350 NEUROTEST: After switching on the neurotest function using the intensity adjuster, a test determined that the electronic fuse was not triggered or the frequency feedback system has failed. <i>Equipment defect: Technical Service.</i>

Chapter 3

Circuit description

Motherboard

The following functions are also found on the motherboard:

- Starting current limitation
- Supply voltage changeover and power rectification
- Power transformer for low voltage supply
- Rectifier for low voltage
- Chipselect generation and level adaptation of TTL level to 15 volt level for CMOS components.
- Generation of the external control bus and of signal lines from the data from PIO outputs
- HF leakage current measurement
- HF leakage current limitation
- Changeover between floating and capacitance-grounded output
- Input circuit for the footswitch
- Various level adaptations.

The motherboard detects the other PCBs via connectors and contacts them.

Starting current limitation

The supply voltage moves from the power supply to the motherboard via the connector J 11.

Immediately after switching on the ICC, the supply unit capacitors are charged which causes a heavy power surge by which, without protective measures, the fuses for the in-house electrical system would be triggered.

Therefore a starting current limitation has been realized on the motherboard which limits the current peak to noncritical values after switching on.

The corresponding power current first flows into the ICC via the resistor R5 and the fuse F1. The relay contacts REL 1 are still briefly opened. Power current is therefore temporarily limited to noncritical values due to resistor R5.

As soon as the 24 volt supply voltage is available, relay REL 1 can pick up, bridges resistor R5 and fuse F1 with its relay contacts, and relieves both of them. This short span of time is sufficient to effectively limit the starting power surge.

LED D2 lights red when the relay REL 1 is actuated and thus serves as a control.

Supply voltage switchover and power rectification

The unit can be changed over either to the 230 volt or 115 volt supply voltage range. The remaining voltage deviations within the specification are offset by the controlled power supply units.

The supply voltage can be switched over by shifting the connectors J 16 to J 22.

In the 230 volt range, the bridge-connected rectifier BR1 functions as intended as a true bridge circuit. The wire bridges must be connected as follows:

Motherboard

J 15	free
J 16–J 20	grey
J 17–J 21	brown
J 18–J 22	yellow
J 19	free

In the 115 volt range, the bridge-connected rectifier BR1 operates with the electrolyte capacitors C6, C7 as a voltage doubler. The wire bridges must be connected as follows:

J 15–J 20	grey
J 16	free
J 17	free
J 18–J 21	brown
J 19–J 22	yellow

For the low voltage supply, there is a transformer TR 1 with rectifier BR2 and filter capacitor C15 on the motherboard. Here an unregulated DC voltage is provided in the 24 volt range.

Since data are present on the databus for all parts of the circuit simultaneously, it is necessary to separately determine for which part of the circuit the currently output data is intended. This is realized by the “Chipselect method” by which the chip to be addressed is selected and addressed using a special “Chipselect signal.”

This signal activates only one among a number of addressable modules. These signals are generated within the Multiplexer IC 4 and converted in the transistor arrays IC10 and IC11 to 15 volt CMOS level.

The PIO (Parallel Input Output module) produces data in a brief period of time for many different target assemblies. While the data are only present briefly at the PIOs, the data for target assemblies should be present longer. For this an independent external control bus and independent control lines are used. The data for the signal lines are stored in the D-flipflops IC2 and IC3 and brought to the 15 volt CMOS level in the transistor arrays IC8 and IC9.

For the external control bus, the PIO data only need to be brought to the 15 volt CMOS level in IC7.

Limitation of the high frequency leakage currents

High frequency leakage currents are effectively limited in the ICC. The transformer UE1 is used for limitation.

All lines which lead to a high-frequency output socket on the ICC are directed via transformer UE1. If no high frequency leakage currents occur, the HF current flows from the generator via the patient to the neutral electrode and via the transformer UE1 back to the generator completely.

Therefore ideally, the current flowing away is equal to the current flowing back. The windings of the transformer UE1 are switched in such a way that the resulting magnetic field is canceled by the current flowing back and forth. Thus the windings of this transformer have no inductivity; the current can flow unimpeded.

However, if high-frequency leakage currents do occur within the patient circuit, the current flowing back and forth is generally not equal. The magnetic fields in the transformer UE1 do not cancel each other out;

Motherboard

an inductivity of the coils results which limits the high-frequency leakage current with this inductive impedance.

Monitoring the high-frequency leakage currents

As intended, the high-frequency current should only be used for cutting or coagulating tissue. To do this, it must flow to the active electrode in a small area and with a high current density, and flow back again from the neutral electrode over a large area and with a low current density.

However, if the body of the patient is in contact with another electrically conductive object, the current may also take an undesirable path and, for example, cause a burn there. These undesirable currents are known as “leakage currents”. It is therefore important to know whether such a leakage current is flowing and how large it is.

Such leakage current cannot simply disappear, but must instead always flow back to the generator. The largest proportion of these high-frequency leakage currents flow back to the generator via the power cable and the grounded conductor.

Since all power lines and the grounded conductor are directed through the ring core of the coil L1, a corresponding high frequency voltage is induced if HF leakage current is present in the coil L1, which is rectified with diode D1, restricted with D6, D7 and smoothed in capacitor C13. For further processing, this DC voltage is fed to the processor system via the isolation amplifier IC12.

Changeover between flowing and capacitance-grounded output

High-frequency surgical units are generally available either in “capacitance ground of the neutral electrode” or “floating neutral electrode” connection systems, whereby no components are integrated between the connection to the neutral electrode and chassis in the latter connection system.

Both connection systems have advantages and disadvantages.

The advantage of capacitance ground is that the feed line from the neutral electrode to the patient is grounded at a high frequency via the capacitor and the risk of burns is reduced. However, it is a disadvantage that impermissible low-frequency leakage currents may flow through this capacitor during cardiac operations.

If the neutral electrode is operated as floating, on the other hand, the low-frequency leakage currents can be kept very easily below the limit value of 10 or 50 mA during cardiac operations, but the risk of burns is increased in this connection system since the line from the neutral electrode is about half the high frequency voltage of the generator.

With the ICC high-frequency surgical units, the low-frequency leakage current to the patient is measured. At the first malfunction, this must not exceed 50 mA. Once this condition is ensured, the unit is permitted to carry the CF designation (Cardiac Floating). If the possible low-frequency leakage current is under 500 mA in the first case of malfunction, the unit is therefore not suitable for operations on the heart and has the designation BF (Body Floating).

Initially the ICC is capacitance-grounded via capacitors C30 and C31 and the relay contact REL 2. The advantages of capacitance ground are fully exploited. The low-frequency leakage current is measured via the prescribed simulation R25, C28. If for any reason a low-frequency leakage current should appear, it is then evaluated. If it exceeds the limit of 50 mA, the relay contacts REL 2 are then opened and thus a low-frequency leakage current can no longer flow. The ICC thus fulfills the CF requirement for cardiac surgery

Motherboard

in every situation.

The voltage occurring in the simulation is proportional to the current and is compared in the operation amplifier IC14 functioning as a comparator to the maximum permissible value that is prescribed and adjustable via the resistor divider R22 and TP1. The signal for switching over the relay REL 2 is present at the BF / CF output.

Footswitch input circuit

The footswitch is operated at a DC voltage of 15 volts via a multipole line. Since the footswitch connection, due to its length of up to several meters, can also function as a receiving antenna and absorb interferences, an RC low-pass is connected directly to the input sockets of the ICC which severely dampens high interference frequencies. The footswitch signals are then regenerated using the buffer IC 13.

For further processing in the processor, the output signals from IC 13 are adapted to the TTL level of the processor. To do this, the noninverting buffer IC5 is used.

Further signals are converted in the same manner from 15 volt CMOS level to the TTL level in the buffers IC1 and IC6.

CPU board

Slot J1

The following functions are located on the PCB:

- The CPU with RAM and EPROM
- The clock generator
- The voltage supply monitor
- The digital input and output via Parallel Input/Output modules (PIO)
- Analog inputs via an A/D converter
- The Chipselect generation
- The safety interlock signal for controlling the activation signals.

As the central processing unit (CPU), the CMOS microprocessor Z84 C00 (IC1) is used together with the EPROM 27 C 512 as the program memory (IC3) and the battery-buffered RAM 5864 as the main memory and constant memory (IC2)

The clock pulse for operation of the computer is produced in the quartz clock generator IC16 and then processed in the two D-flipflops IC13 to a half-frequency, counterphase clock.

In case of a breakdown of the supply voltage, the current computer data must still be “saved” and stored in the battery-buffered RAM. All these tasks are supported by the supervisor circuit IC10 (MAX 691).

The supply voltage is monitored via the resistor voltage divider R3, R4 and the “Powerfail” input (Pin 9, IC10). The data are buffered by a 3 volt lithium battery BT1 which is connected at Pin 1 of the IC10. The circuit also monitors the voltage of this buffer battery. When switching on, the circuit affects a reset of the computer system to a specific initial status and provides the monitoring and functional capability through an integrated “watchdog” circuit.

In addition, the +5 volt supply voltage is also monitored in a separate circuit via resistor R9, diode D1, buffer capacitor C13 and resistor R7 via the PIO IC6, Pin 27.

The digital inputs and outputs of the computer are taken care of by the Parallel Input/Output circuits (PIOs, IC4 to IC7). The input and output ports are specified and connected by the program.

Analog dimensions, processed by the processor, move via the level adaptation (resistor network RN1, resistors R15 to R18) and simultaneous low-pass (capacitors C16 to C19) to the 4-channel analog-digital converter IC14, from whence the data are available to the processor.

Since all system data are present together at the databus, the system must be able to address the target modules to which the data apply. This occurs in a processor system by means of the Chipselect lines by which very specific modules can be addressed via the assistance of “selection signals”.

The Chipselect signals are created in the decoder IC9 from the addresses A3, A4 and A5. Depending on the address, only one output line each is switched to logical low.

All signals from the various fingerswitches and footswitches are summarized and verified in a safety interlock signal as to whether any impermissible overlappings or impermissible conditions are produced. If no impermissible overlappings are determined, the safety interlock signal generates a signal which identifies the passed on data as save. This logic is accepted by the programmable controller IC17.

Low voltage supply

Slot J2

The following assemblies are located on the PCB:

- Voltage regulator for +24 volts
- Voltage regulator for +15 volts
- Voltage regulator for +5 volts
- Voltage regulator for –15 volts
- Three sound generators for the acoustic signals
- Circuit for tone selection
- Tone output amplifier with volume control.

Voltage regulator for +24 volts

The unstabilized DC voltage, gained on the motherboard via transformer TR1 and bridge-connected rectifier BR2, moves to the input of a switched-mode power supply unit. This consists of the integrated switching controller IC3, the memory choke L1 and the free-wheeling diode D1 with the necessary wiring. The output voltage is adjusted via the voltage divider R22, R23.

At the output of the switching controller, a stabilized DC voltage of +24 volts is available. The presence of this voltage is indicated by the LED6.

This voltage is mainly used to operate the relays in the surgical unit.

Voltage regulation for +15 volts

The instable input voltage, the presence of which is indicated by LED 4, moves to the switching controller IC 1. The circuit extensively corresponds to the +24 volt regulation, however the transformer UE 1 is used here as the memory choke which simultaneously taps a part of the connector voltage occurring there for the operation of the – 15 volt regulation.

The output voltage of 15 volts prescribed by the divider ratio of the resistors R30 and R31 is used to operate the CMOS circuits and the operation amplifier. Its proper presence is signaled by the LED 2.

Voltage regulation for – 15 volts

The negative operation voltage of – 15 volts is mainly required for the negative voltage supply of the operation amplifier. Since the capacity of this voltage source is just minimal due to the circuit, a simple regulating circuit could be used. The principle of analog regulation is thus sufficient, and the resulting losses are minimal.

The switched-mode voltage tapped from the switched-mode power unit for + 15 volts at transformer UE 1 is rectified through the diode D6 such that a negative DC voltage is present at the input of the analog regulator IC10. This voltage is stabilized by the fixed voltage controller IC10 to –15 volts. The proper presence of this voltage is indicated by the LED1.

Low voltage supply

Slot J2

Voltage regulation for +5 volts

A controlled voltage of +5 volts is mainly required to operate the CPU, the TTL logic modules and the light displays on the front panel. Since the capacity of this voltage source is relatively high, a switched-mode power supply unit was used.

The circuit corresponds extensively to that of the +24 volt regulator: The instable input voltage is stabilized to +5 volts by means of the regulator IC6. The proper presence of the output voltage is indicated by the LED3.

From Pin 3 of the integrated switching controller IC1 of the +15 volt voltage regulation, a connection leads to the transistor T2 of the +5 volt control. In this way it is possible to block the function of the +5 volt power supply unit as long as the +15 volt supply is not available. This measure is used to increase the functional security of the unit.

Tone generators for the signal tones

The tone generators are used to audibly signal all operating and danger conditions when operating the surgical unit. To do this, three tone generators are available, the signals of which may be mixed with one another to produce pleasant and differing tones in this way.

The timer IC4 produces the tone frequency for the first tone, which can be adjusted using the trim potentiometer TP2 at 493 Hz.

Timer IC5 produces the tone frequency for the second tone, which can be adjusted using the trim potentiometer TP3 at 414 Hz.

Timer IC7 produces the tone frequency for the third tone, which can be adjusted using the trim potentiometer TP4 at 329 Hz.

The generated tone frequencies can now be switched on selectively using the analog switches on the IC8 and mixed with one another. The combination of individual tones is prescribed by the program and is selected using the D-flipflops of the IC9 as a target memory and switched through using the analog switches of the IC8. Via resistors R5, R7, R9, R24, R10 and R16, the tone frequencies are combined so that one sound can result from several individual frequencies.

The volume of the operating tones can be adjusted using a potentiometer which is connected in parallel to resistor R11.

The volume of the alarms must not be reduced. For this reason, the reduction of amplitudes by means of the integrated analog switch IC8, Pin 10-11, which is also controlled by the CPU, can be passed by so that the tone signal in this case is reproduced with the maximum amplitude at the tone output amplifier IC 2.

The R37, C9, C10, C11, R39 network is used for sound shaping, so that a pleasant sound results in the loudspeaker which follows the tone amplifier.

Control board

Slot J3

The following assemblies are found on the PCB:

- Measured value acquisition and adjustment
- The contact monitor
- Actuation and power setting of the ST output stage
- Actuation of the power module
- Synchronization of the QK output stage
- Hardware electronic safety circuits
- Spark control
- Actuation of the QK output stage.

Measured value acquisition and adjustment

The measurement signals, which are triggered mainly to the Senso-board as well as to other parts of the entire unit, move first to the control board where they usually must still be adjusted in order to finally move on to the processor.

For most inputs, an input circuit consists of a variable voltage divider with which the signal voltages can be adjusted.

Various signal voltages, the values of which are needed very quickly by the processor system, proceed via the amplifiers IC1 and IC2 directly to the processor. (See diagram page 2/3).

Other signals which are not required for fast processing can be fed to the processor system in multiplex operation. (Circuit diagram page 3/3). These signals are fed to the 16-channel multiplex IC 3, scanned in chronological order, then amplified in the operation amplifier IC1 and only then fed one after another to the processor system (output ANALOG 4).

The individual operating voltages, for example, are determined in this way:

The +15 volt operating voltage is fed via the resistor divider R39, R40 to the multiplexer.

The +24 volt operating voltage is fed via the resistor divider R41, R42 to the multiplexer.

The -15 volt operating voltage is first fed via R31 to the operation amplifier IC2 by inverting it. Now the voltage can also be processed as a positive parameter via the multiplexer which only switches through positive signals.

The multiplexer IC3 receives its address actuation A0 to A3 from the control bus via the target memory (D-flipflop) IC19.

The contact monitor

In the bipolar operating mode, it is necessary that the generator be switched on via the forceps when biological tissue is found between the forceps tips. This is the purpose of the contact monitor. It should switch on the generator at a tissue impedance of 2.5 kOhm.

In principle, two starting points can be specified and adjusted. The appropriate valid area is prescribed by the control bus, stored in target memory IC20 and switched through there according to the activated output (BER_1 or BER_2).

Control board

Slot J3

For example, if area 1 is activated, the emitter from transistor T2 is set high and gives its output voltage via the trim potentiometer TP 11, resistor R45 and diode D2 to the measurement line U_NETZT, which also leads at the power module to the sensor line of the switched-mode power supply's output voltage, but at the same time also to the measurement system of the processor (trim potentiometer TP1 on the control board).

Transistor T2 can therefore be regarded as an extra-low voltage power supply, the output voltage of which the HF generator of the power module uses to produce a minimal HF voltage and emit this as a test voltage to the bipolar socket.

The internal impedance of this mini power supply unit is adjusted via the trim potentiometer TP11.

If the generator is now loaded with the tissue in the forceps (or with a 2.5 kOhm impedance), the supply voltage at the internal impedance of the mini power supply unit collapses by a specific amount.

This voltage collapse is measured by the processor system and compared with the prescribed set values. If they agree, the main power supply unit is switched on and the HF generator supplies the preset power.

The mini power supply unit cannot be fed in reverse due to the diode D2 (protective diode).

Since the internal impedance can be changed via the trim potentiometer TP11, the starting point of the contact monitor can be adjusted here relative to the loaded impedance of the generator (tissue impedance).

Actuation and power setting of the ST output stage

The instruction to actuate the ST output stage arrives as a digital word from the control bus. From this, in the digital-analog converter IC8, a DC voltage results which is transformed into a specific frequency in the voltage frequency converter IC15, which can be adjusted using the trim potentiometer TP17.

The clock pulse generated in this way is the repetition frequency of the ST output stage actuation.

The pulse length of each individual actuation pulse is taken from the repetition frequency. Using the EXOR of the IC12, a monoflop is realized with which the pulse length of the actuation pulse can be adjusted using the trim potentiometer TP16. After a steepening of the edge, the actuation pulse TSI_STE is available at output 11 of the EXOR IC12.

The generator power can be adjusted via the repetition frequency.

Actuation of the power module

The power generator of the power module is a feedback generator in principle which receives its actuation pulse from the control board. The generator, however, does not begin to oscillate itself, but must instead be started by a pulse.

The circuit receives the start-up signal and thus the necessary starting pulse from the processor via its PIO on the CPU board and the transistor array IC8 on the motherboard.

The HF_EIN signal is directed to the comparator IC14 on the control board, the output of which remains at logical HIGH during activation.

When starting up, the ascending signal is differentiated via the RC element R19, C73 and moves to the gate of the transistor T4 which then briefly connects through and triggers the monoflop IC16. This is the starting pulse at which the generator begins to operate. Using the trim potentiometer TP15, the pulse length of the first monoflop in the IC16 can be set and resulting in a symmetrical sine-wave characteristic for the generator signal (adaptation to the parallel oscillating circuit).

Control board

Slot J3

The resetting of the first monoflop IC16 triggers a secondary pulse in the second monoflop IC16 which represents the true actuation pulse for the output stage driver. The length of this actuation pulse is adjustable using the trim potentiometer TP14.

The power module generator is therefore always only initiated at the start of a half oscillation through the actuation pulse. Due to the oscillating circuit as load resistance, the oscillation is extended into a complete sine wave.

For all further oscillations during an activation phase, the generator is fed back via the resulting sinus signal. A part of the output voltage U_{PRIM} of the parallel circuit is directed to the comparator IC14, the output pulses of which now trigger the monoflops IC16.

The power module generator therefore continues to oscillate as a feedback generator until the activation signal HF_EIN is reaccepted by the processor.

In this way, it is ensured that the generator always oscillates exactly at the resonance frequency of the oscillating circuit and the operating frequency need not be manually adapted to the production-related tolerances of the oscillating circuit elements.

Synchronization of the QK output stage

The quasi-complementary output stage operates at a serial oscillating circuit (on the power module) to produce the required sine-wave current. This serial circuit affects the current in the QK output stage like a flywheel and forces the temporal characteristic of the current to a certain extent.

Due to the improved efficiency and to protect the QK output stage, the transistors should always be switched over at the same time that the current in the serial circuit has just made a zero crossing. This then reduces the losses in the transistors.

This requirement can best be met according to the principle of feedback. Such a circuit principle has already been realized in the actuation of the power module. There too, the advantages of digital control signals with their low electrical power consumption and its versatility could be combined with the feedback for a generator of high efficiency.

The generator cannot start by itself; it needs a starting circuit. The digital oscillator IC18 is a free-wheeling oscillator, the frequency of which should be as close as possible to the frequency of the serial circuit. Its output signal is directed to the priority encoder IC11. As long as no current flows in the QK output stage, the measurement signal of the current U_{IHP} is zero (measurement point MP1). The comparator IC9 detects no current at input 9, therefore its output signal is low and the monoflop IC13 produces no pulses. Its output is then continuously low and thus also the selector S1 of the priority encoder IC11. As a result, the inputs IA2 and IA3 are switched through to the output. In this way, the signal for the starting circuit IC18 or actuating the QK output stage is switched at the start.

Once the QK output stage has “started up”, a current is produced there which, at sufficient level, exceeds the threshold of the comparator IC9, Pin 10. Since the current in the QK output stage is half-wave-shaped, a pulse results at the output of the comparator with the frequency of the QK output stage. This pulse triggers the monoflop IC13 at input 4. The ON time has been selected somewhat longer than the period length of the HF signal of the QK output stage, so that the monoflop does not drop out as long as pulses from the generated HF retrigger this monoflop (principle of the watchdog circuit). The monoflop increases the selector input of the priority encoder IC11 to high-level. In this way, the signal from the start generator

Control board

Slot J3

is no longer switched through for actuation of the QK output stage, but instead the output signal of the comparator IC9, PIN 12.

This comparator detects the zero crossings of the high frequency current of the QK output stage and provides a pulse at the rate of the HF at the priority encoder which switches this rate through to the actuation with sufficient current flow of the output stage. In this way, the actuation has now been switched over from free-wheeling by means of the start generator in a no-load case to feedback current control in a load case.

Hardware electronic safety circuits

The current from the QK output stage is measured one more time:

First the measurement voltage is divided by means of the divider R57, R61, then rectified using diode D10 and an average is generated using the time constants from the resistor R50 and the capacitor C10. As a result, the comparison voltage from the divider is present at the input of the comparator IC4, on the one hand, and on the other, the average of a voltage which corresponds to the average current of the output stage. If the average output stage current exceeds the set threshold, the comparator tilts. Its output signal blocks actuation of the output stage via the AND gate IC7, Pin 4, and the QK output stage is blocked for a specific minimum time prescribed by the monoflop IC10, part 2. In this way, the circuit is provided with a recovery time and a pump effect is avoided.

This is therefore an electronic fuse for the QK output stage.

In a similar manner, further measurement dimensions are monitored not only through software, but also through hardware:

Voltage and current of the patient circuit are directed via their parameters UP_HF and IP_HF from the Senso-board on the comparator IC6. This also applies to the voltage from the power supply unit U_NETZT and its current U_INT from the power module.

The integrated module IC6 is a comparator, the threshold voltage of which can be preset as a digital word via the control bus. In this way, the threshold voltage can be adapted to current requirements prescribed by the processor. The comparator compares the analog instantaneous values with those limit values set by the processor and passes its Yes/No decisions on to the NOR circuit IC5. There the signals are summarized and directed to gate IC7. If one single parameter has exceeded its limit value, the QK output stage actuation is blocked by the AND circuit IC7. At the same time, the monoflop IC10, Part 1, is triggered, maintaining the blockade for a specific minimum time, so that a pump effect caused by switching off and back on again too quickly is avoided.

Via the second part of the AND circuit IC7, further important enable signals are controlled for the QK output stage:

- Is there an enable signal from the processor?
- Is the safety interlock signal giving its enable?
- Is there currently no reset of the processor?

If any of these questions can be answered with NO, the QK output stage is blocked.

The spark control

Several ICC units offer both a control of the HF output voltage as well as optionally a control of the

Control board

Slot J3

sparkling which occurs during the cutting and coagulation process at the active electrode. Both control principles have concrete applications.

The control of spark intensity can be activated via the “HIGH CUT” key.

On the Senso-board, the DC voltage U_FUNKE occurring during a spark is gathered via an isolation amplifier (description there) and directed to the control-board.

The required set value of the spark intensity is transmitted via the control bus to the digital analog converter IC8. Its analog output signal is combined and compared at the comparator IC4 with the actual value of the spark U_FUNKE. If the actual value is greater than the set value, output 12 tilts to frame potential and illuminates the red LED D1. In addition, the output signal moves to the input Pin 2 of the NOR circuit IC5. The gate IC7 with the monoflop IC10 switches off the QK output stage for a minimum period of time. In this way, the supply voltage for the HF generator is reduced and therefore also the intensity of the spark.

Actuation of the QK output stage

The MOS field effect transistors of the quasi-complementary output stage require brief start or stop pulses for their actuation during the zero crossing of the sinusoidal output current.

As is known from the section “Synchronization of the QK output stage”, there is a pulse at the output of the priority encoder IC11 which is already synchronous to the zero crossings of the output current. This pulse must now be prepared in such a way that a start or stop pulse is produced for each of the two output stage transistors at the right point in time respectively.

If one assumes that neither of the two QK transistors are switched conductively after a pause, Transistor A first requires a start pulse. The transistor then switches on and produces a sinusoidal half-wave within the oscillating circuit of the QK output. At the end of this half-wave, this Transistor A must be switched back off using a brief pulse. Then Transistor B should take over the second half-wave and be conductive. Therefore Transistor B requires its short start pulse after Transistor A has switched off. It remains conductive until the zero crossing of the second half-wave and must be shut off again at its end using a pulse.

In this way, a complete sine-wave oscillation has resulted and the process repeats itself constantly until the QK output stage is switched off.

The output of the circuit IC11 produces a pulse with every zero crossing on the sinus current. However, the actuation requires, as described, two pulses during a half-wave, specifically a start and a stop pulse. It is therefore necessary to double the frequency of the available pulse. This occurs in the EXOR gate IC12 together with the RC low-pass R67, C15. Using this low pass, the signal at input 1 of gate IC12 is slightly delayed compared to input 2, which leads to an output pulse with the length of the delay time for every change in the input signal. The input frequency is thus doubled. The resulting pulses are extremely short.

By means of small, though non-negligible running times in the circuit, the signal received in the meantime is no longer completely synchronous to the current zero crossings of the output signal. Using the monoflop IC13, the correct phase relationship of the actuation pulses to the output current can be re-established by specifically extending the pulses. The necessary delay time can be adjusted using the trim potentiometer TP13.

By halving the previously double frequency in D-flipflop IC21, Part 2, the original operating frequency of the QK output stage is recreated with a pulse duty factor of 1:1. Output pin 13 has a HIGH level, while Transistor A is addressed. The inverted output 12 has a HIGH level, while Transistor B of the QK output

Control board

Slot J3

stage is addressed. The output signals A and B thus serve in the selection of currently active transistors.

From the previously doubled frequency, the short start and stop pulses are produced for the respectively active transistor.

The first part of the monoflop IC17 produces the start pulse, the second part the stop pulse.

The first part of the D-flipflop IC21 is additionally actuated by an ON_OFF signal for the safety circuits. In this way, all start pulses can be suppressed on the one hand, while on the other, it is ensured that the transistors can still be shut off in any case.

The arrangement of selection pulses for the individual transistors with the on/off pulses is made in the NAND gate IC1 on the QK output stage.

QC power stage

Slot J4

The QC output stage (30128- 528)

The following functions are located on the PCB:

- Decoding of the switch signals
- Power-on time-delay circuit
- Pre-amplifier, driver and electrical isolation of actuation
- Clamping circuit
- Push-pull output stage.

The output stage acts as a power amplifier for high-frequency signals, as is required, for example, in switched-mode power supply units and high-frequency surgical units. This output stage is designed for push-pull operation on account of the greater efficiency and larger possible output power. As there are frequently problems in procuring and storing identical P and N channel transistors - which are required for a push-pull output stage - it is advantageous to be able to use two transistors of the same type. This circuit is then called a quasi complementary output stage, or QC output stage for short.

The aim of the development was to produce an output stage with the highest possible efficiency and a sinusoidal output signal with the smallest possible proportion of harmonic frequencies. Actuation should require as low a power as possible and preferably be possible in digital mode so that the transistors can be used in switching operation with low power loss.

All the stated requirements led to the present circuit.

Circuit principle

The complementary output stage consists of two N channel MOS-FET transistors, T1 and T2, which are operated alternately as switches. The amplified digital output signal is present at the source of transistor T1 and simultaneously at the drain of transistor T2, since these connections are conductively connected to each other. However, since a sinusoidal output signal is a required condition, the output of the output stage is switched to an oscillating circuit (which is located on the next PCB).

The QC output stage is actuated between the gate and source of the respective transistor, which always leads to electric potential problems with this circuit logic, since the actuation signal has to be superimposed on the output signal.

This problem can be solved by actuating the relevant transistor via a transformer. If this method is used for both output stage transistors, it has the advantage that the actuation circuit can be completely isolated from the output circuit and the high output voltages occurring in the event of a defect cannot damage the actuation circuit.

The disadvantage, however, is that the transformer cannot transmit any DC signals.

This is where the gate-source capacitance of the MOS-FETs proves useful. Since this capacitance is of high quality, the gate-source capacitance can maintain an applied charge for a sufficient length of time. The clamping circuit consisting of diodes D8, D9, D10 and D5, D6, D7 has the effect that the gate-source capacitance can be charged with a short positive pulse. This positive pulse is fed via diode D8 to the gate of transistor T1 and charges the GS capacitance sufficiently for the transistor to be switched to a conducting state.

QC power stage

Slot J4

This charge cannot then flow back into the actuation circuit after the actuation pulse has ended, since diode D8 acts as a block and diode D9 also permits no reverse current due to its Z-diode characteristic. The result is that the transistor remains in a conducting state as long as its GS capacitance has sufficient charge.

If, on the other hand, a sufficiently large negative pulse comes from the actuation circuit, the Z-diode voltage at diode D9 is exceeded and the GS capacitance can be discharged again. Transistor T1 thereby acts as a block.

It can thus be seen that a MOS-FET transistor can be operated in switching mode via such a clamping circuit by means of a pulse transformer with short start and stop pulses.

Capacitors C4 and C5 are connected in parallel to the GS capacitance and support the effect described. Since their capacitance is significantly higher than the corresponding gate-source capacitances, the circuit becomes largely independent of parameter scatter of the gate-source capacitances of different production batches.

It is the task of actuation to time the actuation process in such a way that each of the two power transistors receives a short start pulse and, after a defined pause, a stop pulse at the right time. It must be ensured that the two transistors are never switched to a conducting state simultaneously, since a short circuit of the supply voltage would result!

Circuit description

The actuation signals are generated on the control board (30128-357). These signals are short pulses for starting and stopping the output stage transistors and two additional pulses, one for selecting the upper output stage transistor and the other for selecting the lower output stage transistor.

These pulses come via connector J1 to the NAND gates $\frac{1}{2}$ IC1 and IC4 on the QC board. There the "Start" and "Transistor A" pulses, for example, are brought together (as are "Stop" and "Transistor A"). The following pulse sequences are thus present at the outputs of IC 1:

- Start transistor A
- Stop transistor A
- Start transistor B
- Stop transistor B.

These pulses are each preamplified in the triply parallel gates of the NOR circuits IC 2 and IC3. The outputs of IC2 and IC3 actuate the driver stages, each consisting of two parallel transistors T3 to T10. The output signal of the four parallel drivers is then amplified to such a level that the pulse transformers UE1 and UE2 can be operated with sufficient energy.

In the case of a complementary output stage, it must be strictly ensured that the two output stage transistors are not simultaneously in the activated state, as this would cause a short circuit across the two transistors and damage the output stage beyond repair.

Therefore, the stop pulses generally have the highest priority. They ensure a safe state of the output stage during undefined operation. The start pulses are separated in the actuation logic to ensure that only one output stage transistor is actuated at any one time.

An undefined state could, however, occur in rare cases if the +15 V operating voltage is too low at any point

QC power stage

Slot J4

in time. For this possibility, in which the logic might operate undefined, a "Power-on time-delay circuit" avoids undefined starting of the output stage transistor.

With transistor T11, the supply voltage $V_{DD} = +15\text{ V}$ is monitored. If this voltage is missing, capacitor C10 is quickly discharged via diode D12. This logical LO signal is sent to the two NAND gates $\frac{1}{2}$ IC 1 and blocks the starting pulses. If the supply voltage is present, capacitor C10 is charged to 15 V via transistor T11 and resistor R8 in a predefined delay time. This HI signal reaches the two NAND gates again (see above) and enables the start pulses for the output stage.

On the secondary side of the driver transformers, short, steep spikes occur, initially a positive pulse for starting, then a negative pulse for stopping the corresponding output stage transistor.

These spikes reach the gates of the MOS-FET transistors via the clamping circuit described above, and switch the gates.

The amplified output signal is tapped at the two mutual connection points of the transistors.

Power module

Slot J5

Power module UL

Slot J5

The following assemblies are found on the PCB:

- Serial oscillating circuit for the QC power stage
- Generation of the operating voltage for the HF generator
- Driver and output stage of the HF generator
- Output circuit of the HF generator
- Measurement of various operating parameters

Serial oscillating circuit for the QC power stage

The QC power stage has the task of generating a sine-wave current as free of distortion as possible. The QC power stage is not used in the ICC to generate high-frequency power for cutting or coagulating, but instead functions here as a switched-mode power supply unit with a high switching frequency and efficiency. The QC transistors are always switched over in the zero crossing of the current. The current is forced at the same time through the serial circuit from coil L2 and capacitor C17 into a sinusoidal shape.

Generation of the operating voltage of the HF generator

The high-frequency power is tapped via the transformer UE2 and rectified by means of the diodes D3, D4. The capacitors C4, C10 are filter capacitors. With 22 μ F, they can be measured relatively minimally and the ripple of the output voltage is nevertheless small due to the high operating frequency. In this way, this switched-mode power supply unit can also be stabilized very quickly.

The output DC voltage of the power supply unit is available at the cathode of diode D3 and is

- a) directed via the U-NT-STE connection to supply the ST output stage,
- b) used to operate the HF output stage via relay REL1.

The negative pole of the capacitor C10 leads to the chassis via the resistor R5. R5 is used as a shunt to measure the output current taken from this power supply unit. The voltage allotted to R5 is used for measurement by U-INT.

In the activation pauses, the power supply unit can be discharged via NTE (power supply enable). To do this, the transistor T3 is switched conductively and discharges the stored power supply voltage via the resistor R12.

The power supply output voltage is divided into smaller values via the resistor divider R7, R8 and lead to the measuring device (U-NETZT).

Via the relay REL1, the transformer UE2 can be switched over. With an activated relay, a higher output voltage can be taken from the transformer. This is required to operate the ST output stage to generate especially high voltage peaks. This high voltage is switched off to protect the HF output stage by means of the second contact from relay REL1.

Power module

Slot J5

Power module UL

Slot J5

Driver and output stage of the HF generator

The actuation signal for the HF output stage is generated on the control board (IC16) and fed to the power module driver IC1 via the motherboard.

Due to the high-gate source capacitance of the output stage transistors T1 and T2, the driver must be able to emit and accept high reactive currents when transferring this capacitance. That is why two drivers are switched in parallel. The output current of the driver is restricted by the resistors R1 and R19 to protect the driver.

The output stage transistors T1 and T2 are switched in parallel due to the necessary high current and operate on output transformer UE1.

Output circuit of the HF generator

The output circuit of the output stage consists of the transformer UE1 on the primary side and the two capacitors C5 and C7 switched in parallel. This parallel circuit is designed for the operating frequency of the HF generator and forms a sine-wave voltage in a no-load case.

At the secondary side, there is a serial circuit made up of coil L1 and the capacitor C1. This serial circuit is also designed for the operating frequency of the HF generator and produces a sine-wave current in the output circuit.

In this way, in every load state of the generator, both the voltage and the current are sinusoidal.

Measurement of various operating parameters

The output current in the QC power stage flows via the transformer UE3 which is secondarily loaded with the resistors R13, R14 and R15 and is used as a current transformer.

The voltage at these resistors corresponds to the output voltage of the QC power stage (half-cycle current) and is routed as U-IHP to the control board.

The current in the power supply unit is measured at shunt R5 and routed as U-INT (voltage as a function of the power supply current) to the control board.

The output voltage of the power supply unit is divided via the resistors R7, R8 and routed as U-NETZT to the control board (IC14).

The HF primary voltage of the output stage is picked up at the oscillating circuit capacitor C5 and routed as U-PRIM to the control board (IC14).

The output stage temperature is recorded by the thermistor NTC1 and routed as voltage from the divider R2, NTC1 with the designation TEMP to the control board (IC2).

ST power stage

Slot J6

The following assemblies are located on the PCB:

- Output stage with driver for high HF voltage pulses
- Relay with relay control
- Feedback of actuation frequency for the CPU

ST power stage

The ST power stage is used to generate high pulses for coagulation without a cutting effect, particularly for quick superficial coagulation.

The designation “ST” output stage is derived from the abbreviation of spray generator for TUR.

The power control and the generation of actuation pulses are found on the control board.

The actuation pulses (TSI-STE) move to the driver IC4 and then to the ST output stage transistor T1. This operates on the output transformer UE1, the secondary side of which emits the high frequency via the capacitors C1 and C2 as well as the relays REL1, REL2 and REL3 at the connections AE and NE. The emitted high frequency is fed to the outputs via the Senso-board.

The capacitors C1 and C2 serve as a high-pass for suppression of faradic effects and are also an additional protection in isolating the patient circuit from the equipment circuit. Due to the necessary high electric strength, two relay contacts each are switched in series.

The output relay is actuated via the relay driver IC7 which receives its actuation signals via the bus and the target memory IC6 (D-flipflop).

The ST power stage is supplied with voltage that is switched with relay REL19 from the power module via the connectors J2 and J3.

The integrated counter IC1 subdivides the frequency of the actuation signal of the ST output stage to a low frequency, so that the frequency in the CPU can be determined by means of a counting loop.

Since the processor prescribes the actuation frequency, it receives feedback in this way as to whether the set and actual values agree. This is important since the output power of the ST power stage is controlled via the repetition frequency of the individual pulses.

Senso-board

Slot J7

The following assemblies are located on the PCB:

- Current monitor for the patient circuit
- Voltage monitor for the patient circuit
- Phase monitor for the patient circuit
- Spark monitor for monitoring the sparking at the electrodes
- Safety system for the neutral electrode (NESSY)
- Relay control

Current monitor for the patient circuit

The high-frequency current moves from the generator to the Senso-board via the connectors J1 and J2. On the way to the electrodes, the current is directed by the transformer UE1, the load resistors R11 and R12 of which are transformed at a ratio of 2500:1 to the primary side and thus serve as a shunt for current measurement.

The output voltage of the secondary winding is also proportionate to the high-frequency output current.

This voltage now moves to one of the operation amplifiers IC7 and IC8, which represent an »ideal rectifier« together with the diodes D27, the capacitor C30 feedback resistor R30.

The rectified voltage IP_PAT is lead via the control board to the processor and, after further amplification in the operation amplifier IC8, is also lead as voltage IP_PAT A for adjustment at the trim potentiometer TP6 also to the processor.

The output voltage of the transformer UE1, on the other hand, moves after a restriction through the diodes D16, D17 to the comparator IC3, the open collector of which operates at the resistor R23. There the zero crossings of the HF current are detected, together with the second part of the comparator IC3, at the output of which a signal according to the zero crossing of the HF voltage is present. Using the common load resistor R23, this circuit represents a “WIRED OR”. There is a digital signal at the output the pulse length of which corresponds to the phase relationship between voltage and current of the HF signal.

The voltage monitor for the patient circuit

Parallel to the lines which lead to the active electrode AE and the neutral electrode NE, the high-frequency voltage is picked up and led via the capacitor C1 to the transformer UE2, which transforms the voltage by a factor of 12.5 weakened to the secondary winding.

After a further halving of the measurement voltage in the resistor divider R15, R16, it moves, similar to the situation in a current monitor, to an active, ideal rectifier, consisting of the operation amplifiers IC4, IC8 as well as the diode D23, the capacitor C33 and the negative feedback resistor R52. The parameter for the high-frequency patient voltage UP_HF is then led to the processor via the control board, as is also the amplified signal UP_HF A.

At the same time, the output voltage of the transformer UE2 is directed to the comparator IC3 which emits a digital signal to the “WIRED OR” during its positive phase. (See above for description).

Senso-board

Slot J7

Phase monitor for the patient circuit

The phase monitor determines the phase angle between the voltage and current in a high-frequency patient circuit. In this way not only the apparent power, but also the active power emitted to the patient can be calculated.

As already described in the *current monitor* and *voltage monitor* sections, the zero crossings of the voltage and current characteristics are evaluated in the comparators of the open collector operation amplifier IC3 and summarized as “WIRED OR” in the load resistor R23. There is therefore a digital signal at the output 7 of the IC3, the pulse length of which corresponds to the phase relationship between the current and voltage.

This signal is smoothed using the diodes D20 and D21, the resistor R40 and the capacitor C13 (averaging), then amplified and decoupled via the operation amplifier IC9.

The voltage U_PHASE corresponding to the phase between the HF current and HF voltage is directed to the control board and can be adjusted there using the trim potentiometer TP 7. The result is fed to the processor.

The spark monitor for monitoring the spark cycle at the electrodes

During the cutting process, for example, there is sparking at the active electrode. To maintain a consistent quality for the cut, the spark must be recorded and controlled in its intensity.

Our generators produce sine-wave output voltages with a very low distortion factor. If a spark occurs in a patient circuit, harmonic frequencies of the output signal are thus produced by the nonlinear characteristic of the spark channel. Harmonics can be either harmonics or DC voltage. This is why one can also say “rectifier effect of the spark”.

The DC voltage resulting in this way moves from the patient circuit to the spark monitor of the ICC. It moves via the resistors R1, R2, R4 and R5 to the Z-diodes D1 and D2, switched antiseriably, which limit the signal to 15 volts. Then follows the operation amplifier IC2, switched as an isolation amplifier, which makes the DC voltage signal durable.

The DC voltage proportional to the spark intensity in the patient circuit must now be evaluated by the unit and fed isolated to the unit circuit. The remainder of the circuit is in principle an isolation amplifier: DC voltage signal is chopped, fed isolated via a transformer to the unit circuit and then rectified again.

The oscillator module IC1 produces a square-wave signal with a pulse duty factor of 1:1, present at outputs 10 and 11 of the IC1. This is the chopper frequency which actuates the transistor T1 and T2 in push-pull operation. This push-pull amplifier functions on the output transformer UE5, which is operated via the isolation amplifier IC1 using the spark voltage as the operating voltage.

In this way, the spark voltage is chopped from the transistors T1,T2 and fed via the transformer UE5 as an isolation at the secondary side to the unit circuit as AC voltage.

Diode D15 then follows on the secondary side, which again rectifies the alternating signal thus resulting and smoothes this by means of the capacitor C22.

Senso-board

Slot J7

In this way there is another DC voltage, proportional to the spark intensity, which is reduced via the resistor divider R32, R33 and then fed to the isolation amplifier IC9. The output signal U_FUNKE moves from there via the control board to control the processor.

The electronic components of this isolation amplifier within the patient circuit require an isolated voltage supply to function. For this, a DC/DC converter is used which consists of a Colpitts oscillator (circuit around Transistor T6), the alternating signal of which is transferred from the transformer UE6 to the secondary side and rectified by diodes D4 and D6. The DC voltages thus resulting are limited to 9.1 volts by the Z-diodes D3 and D5 respectively.

In this way, voltages of +9.1 volts and -9.1 volts are available to the electronic circuit within the patient circuit which is identified with I+9 and I-9.

Safety system for the neutral electrode (NESSY)

Problem description: The line for the neutral electrode must be monitored for wire break according to the standard since there is risk of topical burns for the patient with an incorrect supply line.

In the ICC, correct application of the neutral electrode on the patient is also checked, as well as the uniform distribution of the HF current to the two electrode surfaces (symmetry).

To monitor the connecting line, the cable is designed as a two-wire connection, the loop resistance of which is measured. If the resistance value determined in this way is below a specific limit value, one can assume that the neutral electrode line has no wire break. With conventional single-surface neutral electrodes, monitoring is performed in this way.

However, such monitoring cannot determine whether the neutral electrode is actually applied to the patient or whether it is lying around somewhere else.

To also check the correct application to the patient, the contacts of the neutral electrode must be divided, whereby a control current must flow over the electrode halves and the patient. This control current permits resistance measurement of the tissue impedance of the patient and thus information as to whether

- the electrode is not connected or has a wire break (impedance > 120 ohms),
- is lying directly on the operating table (impedance < 5 ohms),
- or, most probably, is correctly applied to the patient (impedance between 5 and 120 ohms).

If the high-frequency current is not flowing regularly over both surfaces of a divided neutral electrode, this can lead to burns due to current concentration under the electrode. It is therefore also necessary to check the symmetrical current distribution on both halves of the electrode.

The NESSY system, a neutral electrode safety system patented by ERBE, takes care of all the tasks mentioned.

Principle of the NESSY measurement system

The electric resistance of the neutral electrode is measured via an oscillator, the amplitude of which is dampened by the resistance from the patient and measured by the system. With a correct circuit design, a sufficiently precise resistance measurement is possible in this way.

Senso-board

Slot J7

The symmetry of HF current on the halves of the neutral electrode is measured by a symmetrical transformer, the output voltage of which is a function of current symmetry.

Implementation: The circuitry is found on the Senso-board. The oscillator is designed as a frequency-selective feedback amplifier: The amplifier IC6 actuates the push-pull stage, consisting of the transistors T4 and T5, and passes the amplified output signal to the frequency-selective serial circuit made of capacitor C20, coil L1 and the inductivity from the primary side of transformer UE4.

One part of the output signal at the transformer UE4 is picked up via the resistor R18 and fed to the active bandpass from the operation amplifier IC5 and its wiring. The center frequency is equal to the resonance frequency of the previously mentioned serial circuit.

One part of the output signal from the active bandpass is fed again in proper phase to the amplifier IC6, such that the entire arrangement fulfills the oscillation condition and oscillates at the resonance frequency as an oscillator.

The oscillator can be switched off via the transistors T7 and T8 by means of the disable signal OSZI_DIS from the processor.

The resistance of the neutral electrode is determined by loading this oscillator with the resistance to be measured. The voltage collapses on the internal impedance of the oscillator according to the load. Thus every oscillator voltage can be assigned an appropriate resistance value.

The oscillator voltage is present at the input of the active bandpass and can be picked up at the output of the operation amplifier IC6.

After peak rectification by diode D30 and capacitor C34, the measurement voltage U_NESSY can be picked up at the isolation amplifier IC9 and moves via the adjustment on the control board (trim potentiometer TP9) to the processor to determine the resistance of the neutral electrode.

The high-frequency output voltage for the neutral electrode is balanced by the capacitors C2 and C3 on both lines to the neutral electrode, i.e. divided equally.

Whether the current on both lines to the neutral electrode is now of equal size, depends on whether the two electrode halves of the split neutral electrode are applied with the same surfaces to the patient. By measuring the symmetry of the current and the resistance, it is therefore possible to receive information as to whether the electrode is applied well to the patient with this entire surface.

The high-frequency current flows via the two primary windings 1 and 2 of the transformer UE3 in such a manner that the resulting magnetic flow is cancelled out by equally strong currents. Thus in this case, no voltage is induced at winding 3 of the transformer UE3. The reverse is true: The more unsymmetrical the current flow is, the greater the voltage induced in winding 3.

The high-frequency output voltage, which is a measure for the unsymmetry of the current flow, is rectified using diode D9 and filtered with capacitor C57, then amplified using the operation amplifier IC9, so that a signal U_SYM is available which moves via the control board to the processor for evaluation.

The current density is calculated mathematically from the following dimensions, now known:

- High-frequency current,
- Symmetry of the high-frequency current at the neutral electrode,
- Contact resistance of the neutral electrode to the body of the patient.

Senso-board

Slot J7

The relay control

The relays REL1, REL2 and REL3 are used to switch on the required output sockets. The relays are controlled by the control bus via the target memory D-flipflops IC10 and the transistors T9, T10 and T11.

Relay board

Slot J8 (for ICC 300, 350)

The following assemblies are located on the PCB:

- Fingerswitch monitor 1
- Fingerswitch monitor 2
- Relays and their actuation for optional, separate connection of high-frequency to the required output sockets.

The fingerswitch monitors are used to activate the surgical unit from the surgeon's handle. The monitor can detect which output sockets carry high frequency and which current quality (cutting or coagulating) should be switched on.

Since the handles are within the patient current circuit electrically, the monitor circuits must be designed isolated from the unit circuit and from the chassis.

The monitor circuits must therefore be supplied with current from a floating voltage source. These voltage sources must however also be well isolated at high frequencies, such as are used in high-frequency surgery. This means that monitors with their voltage sources must be designed as low capacity compared to the rest of the unit.

The voltage supply for the monitors is realized by two push-pull converters.

The voltage converter for monitor 1 essentially consists of the transistors T1, T2 and the transformer UE 1.

The voltage converter for monitor 2 essentially consists of the transistors T5, T6 and the transformer UE 2.

The transistors of this converter are monitored via the oscillator IC 6, which supplies a symmetrical, square-wave signal, that is shortened in the monoflop IC5, in such a way that it is ensured that the two transistors of a converter are not switched on at the same time.

The NAND circuits of the IC 4 create an appropriate push-pull signal that is directly suitable for actuation of the converter transistors.

Since both fingerswitch monitors have identical circuits, the circuitry of only one of the two monitors is explained in the following:

On the secondary side of the converter transformer UE 1, a needle-shaped output signal forms in the mid-frequency range which is directed both to the diode bridge D1 to D5 with the transmitter diode from IC 1 as well as via the RC low-pass C3, R2, C1, R1 on the handle's selection keys.

Due to the bridge circuit for diodes D1 to D5, the transmitter diode for optocoupler IC 1 may be illuminated during both half-waves and connect through the receiving transistor for the optocoupler IC 1 by pulses.

If, on the other hand, a key on the handle is pressed, a voltage needle for the converter voltage is dampened by the Si diode integrated into the handle, so that the transmitter diode for the coupler IC1 can no longer be illuminated for the affected voltage needle and the appropriate transistor is no longer connected through at exactly this voltage needle.

The output signal from the receiving transistor is directed to the two data inputs for the D-flipflops of the IC3. These two D-flipflops additionally receive the actuation signals for the converter transistors, so that a definite assignment is possible here between the dampened voltage needle and the actuation signal. The two D-flipflops therefore function as a scanning circuit in proper phase, the output signal of which can be assigned to the switched key in the handle.

Relay board

Slot J8 (for ICC 300, 350)

Since a diode is switched in series for each of the two pushbuttons on the handle, although both diodes have a definite and opposite polarity, this circuitry can be detected exactly via the dampened half-wave after pressing a pushbutton, as to whether and which button was activated. Outputs 2 or 12 on the IC3 therefore provide reliable information as to whether the “cutting” or “coagulating” key was pressed. The information that no key was pressed is just as possible as the information that both keys were pressed simultaneously.

Isolation of the fingerswitch monitor is complete via the transformer UE1 and via the optocoupler IC1.

The function of the second fingerswitch monitor is equivalent.

The two relays REL 1 and REL 2 are also found on the same PCB which safely separate the two output sockets for the active electrodes from the generator circuit when the unit is not activated, while connecting only the activated output socket to the generator when the unit is activated.

Due to the higher electrical strength that can be achieved, two relay contacts are switched in series.

The two relays are activated from the CPU via the target memory D-flipflops IC8 and the transistors T3, T4.

Display board

The following assemblies are found on the PCB:

- 7-segment displays and their actuation
- Keyboard and LED matrix for light fields
- Operating board bus and keyboard treatment
- Target memory and driver for rows and columns of the display matrix
- Jumpers for activation of special software

7-segment displays and their actuation

All settings on the ICC are, insofar as this concerns numerical values, shown on the display board with 7-segment displays.

The data to be displayed come from the operating board bus system B1BUS via the target memory (8-fold D-flipflops) IC5 and IC7 on the segment driver IC6. This results in the bus for the segment actuation identified as S1BUS.

The segment bus S1BUS controls the series resistors necessary for current limitation in the LEDs the segments A to F and decimal point DP for the displays LED1 and LED2.

The columns are selected by the target memory IC5 via column driver transistors, which are depicted in the circuit diagram each directly over the 7-segment displays.

In this way, every individual segment within the matrix is addressable via the column selection and the segment control.

Keyboard and LED matrix for light fields

All keys for entering operating parameters are designed as membrane buttons and switched electrically in the form of a matrix with columns and rows.

In addition, all visual displays with the exception of numerical displays are designed in the form of LED displays or LED fields which are electrically switched as a matrix.

Operating board bus and keyboard treatment

To control the operating and display board, an independent bus system is required that is derived from the address bus (A0 to A7). To do this, the addresses A0 to A7 are inverted in the transistor array IC12 and through the transistor T21 and forming the operating board bus B1BUS, which now addresses the target memory of the display board in conjunction with the corresponding independent chipselect signal from the inverter IC8 and the required assemblies.

The rows of the keyboard are multiplexed via the target memory IC1; this produces the row actuation pulses TZ1 to TZ4 (keyboard row).

If a specific key is now activated, this sends its answer during its activation time via the row actuation pulse as an output signal via a line for the keyboard columns TS2 to TS3 to the keyboard encoder IC11, which forms a 4 bit binary number from this and directs it via its output to the CPU for evaluation.

Display board

Target memory and drivers for rows and columns of the display matrix

The LED matrix is actuated by the already described internal bus system B1BUS of the display board.

The 8-fold D-flipflops IC2, IC3 and IC12 are used as target memories for columns (IC2) and rows (IC3).

The columns of the lamp matrix LS1 to LS6 are activated via the driver transistors T2, T20, T11, T10, T4 and T9 switched as emitter followers in a multiplex method and each switched for a brief time to +5 volts.

The current is then led via the appropriate LED and directed via the necessary current limitation resistors as well as the transistor array IC4 to chassis.

The blue LEDs D36 and D37 for display of the coagulation channels are an exception, the anodes of which are permanently at +5 volts via the current limitation resistors and are switched on via the transistor array IC13.

Jumpers for activation of special software

Jumpers J3 to J10 are intended for software specialities available for tests and for switching on special features in certain countries. The corresponding jumpers are already placed during production and must not be changed arbitrarily.

Upper wiring module

The “upper wiring module” PCB directs the rectified supply voltage from the motherboard via the plug J14 as a supply voltage to the QC power stage. In addition, this PCB is used as a connection between the QC power stage and the power module, since currents of this dimension cannot be directed via the motherboard.

The lines between the QC power stage and the motherboard are directed through a ferrite core to reduce interferences from the QC power stage into the network.

CAUTION



This PCB is at supply voltage potential

Chapter 4

Block diagrams

ICC 300

Block diagram

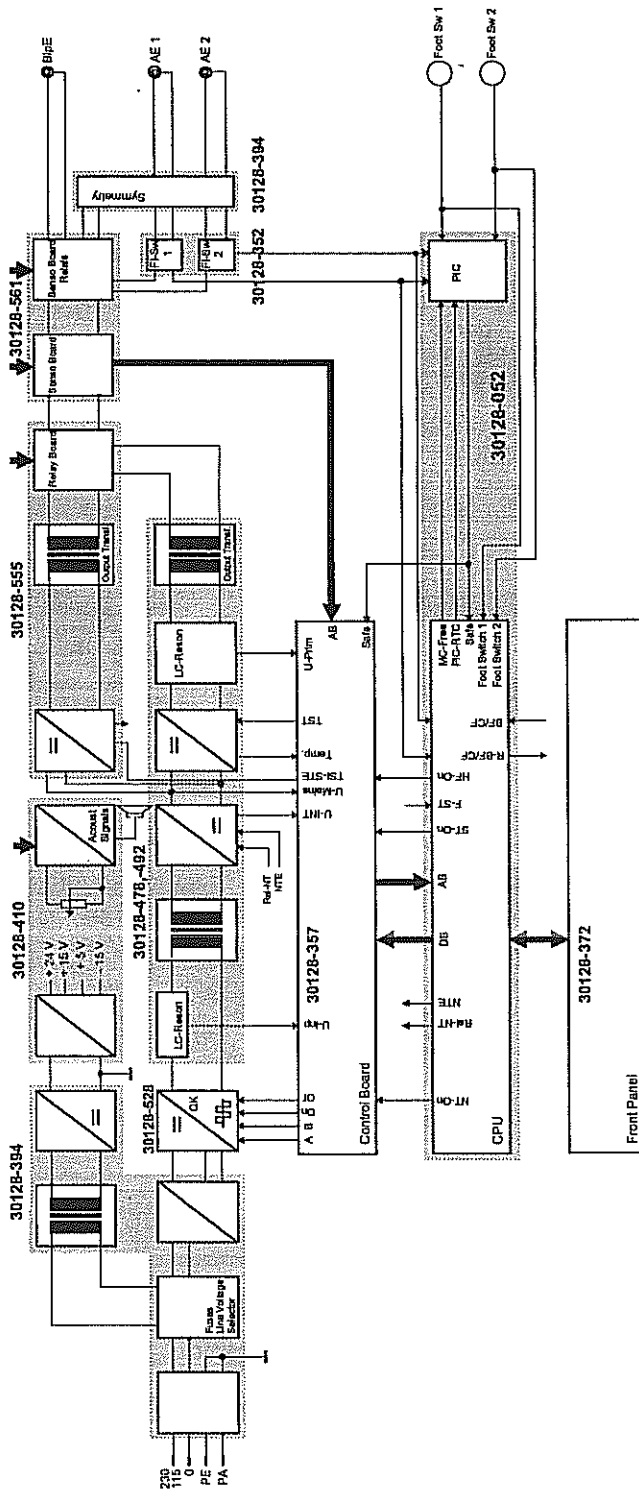

Datum	Name	Maßstab	Titel
01.07	V. Kumburg		V 2.0 / V 4.0
Beschl. geprüft	Projekt	Benennung	Block Diagramm
Freigabe		Nummer	ICC 300
		Erz. für	Erz. durch
ERBE 72072 Tübingen			

Gezeichnet = Drawn

Geprüft = Checked

Freigabe = Approv.

Datum = Date*

Name = Name

Maßstab = Scale

Datei = File

Projekt = Project

Benennung = Title

Nummer = Number

Ers. für = Replaces

Ers. durch = Repl. by

ICC 350

Block diagram

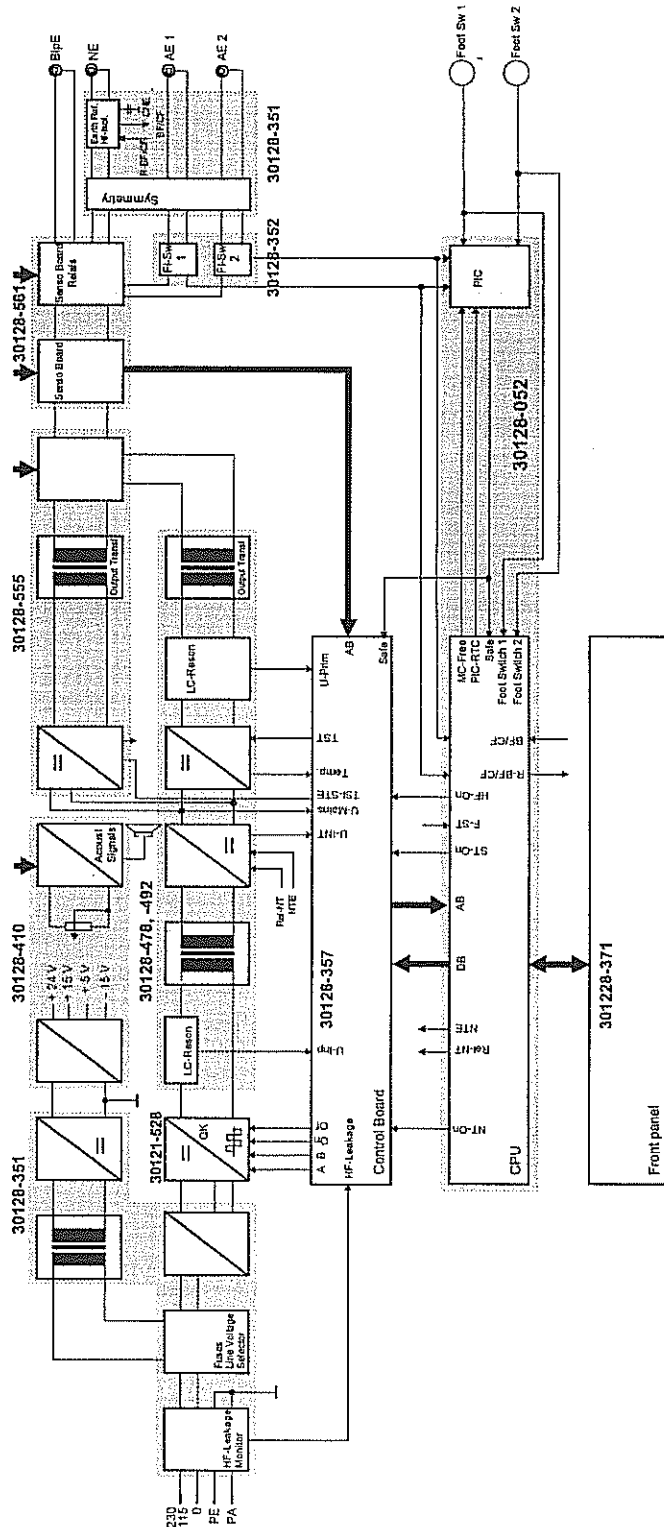

Dates	Drawn	Modified	Initial
Version	02/87	V. Kretzberg	Project
Author			V 2.0 / V 4.0
Freigabe			Release
ERBE			
72072 Tübingen			
Block Diagramm			Erz. durch:
ICCC 350			

- Gezeich. = Drawn
- Geprüft = Checked
- Freigabe = Approv.
- Datum = Date*
- Name = Name
- Maßstab = Scale
- Datei = File
- Projekt = Project
- Benennung = Title
- Nummer = Number
- Ers. für = Replaces
- Ers. durch = Repl. by

Chapter 5

Circuit diagrams

PCBs for

ICC 200, 300, 350

ICC 200, 300, 350

CPU PCB (bare) 40128-026

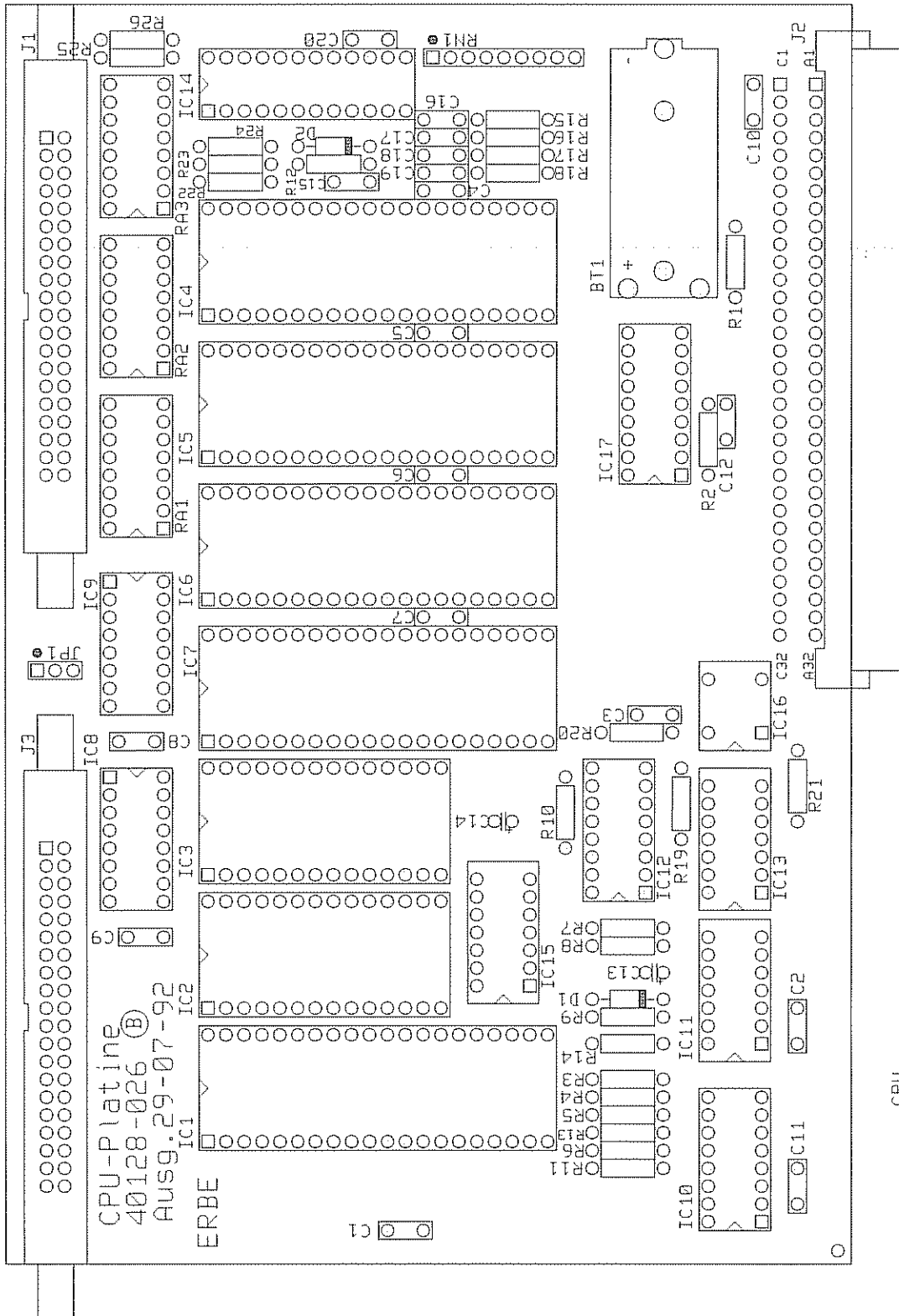

CPU
 40128-026
 16-02-98

ICC 200, 300, 350

Low Voltage Supply 30128-410

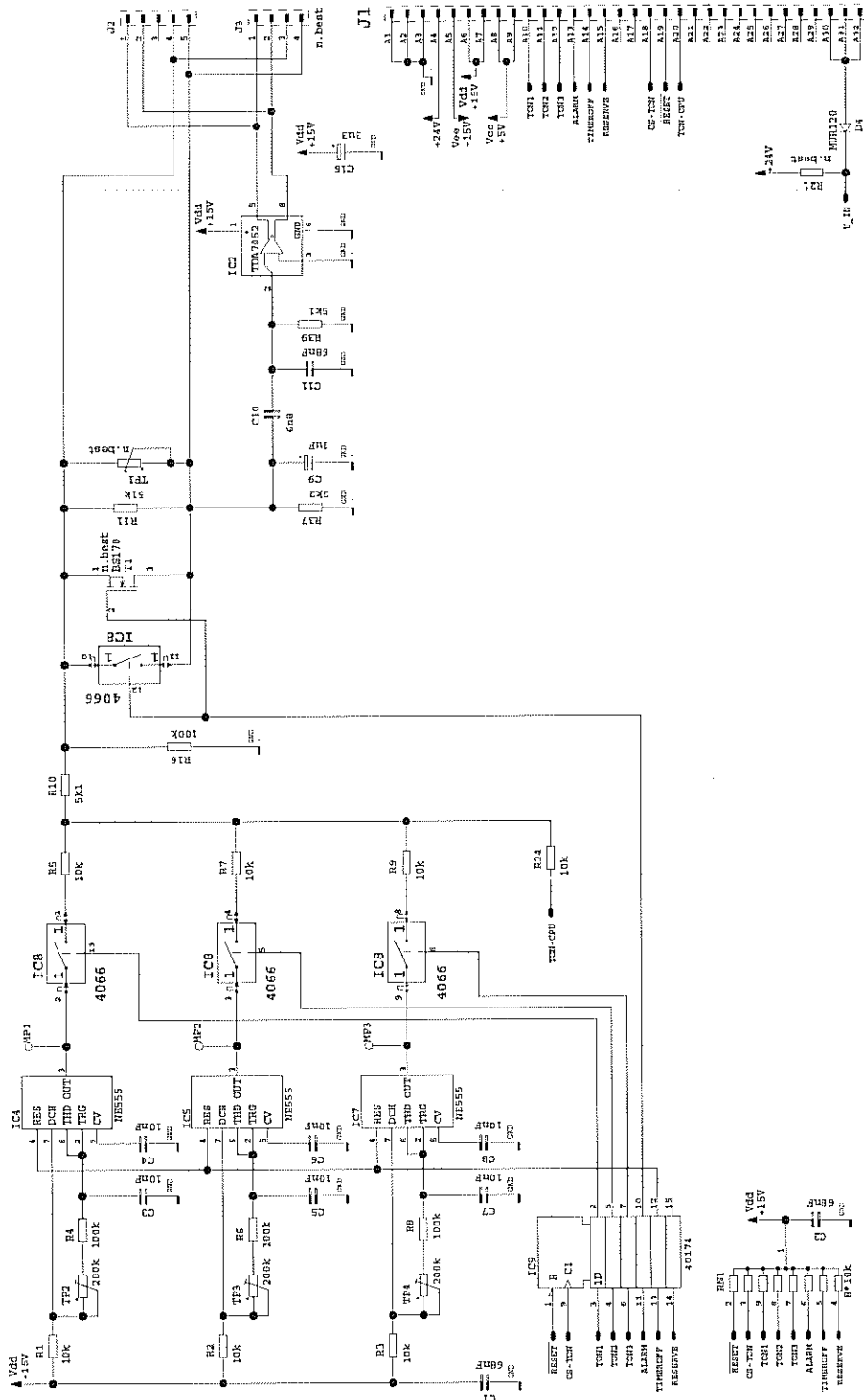

A	DNNAME	MESS	DATE	ZEICHNUNG
	Gerätech. 20-07-94	M.Fritte		ICC
	Gepr ft 20-07-94	H.Heller		Besamnung/Photo
	LP un. : 40121-060			Kleinsp.Netzteil
	LP bs. : 30128-410			Zeichnungsnummer/DWG.Nr
	Blatt 2 von 2			30128-410
RF.	aderungs	Datum	Name	
				ERBE 72072 Tübingen

Art. No. 80116-201
09/2004

ICC 200, 300, 350

Control board 30128-357

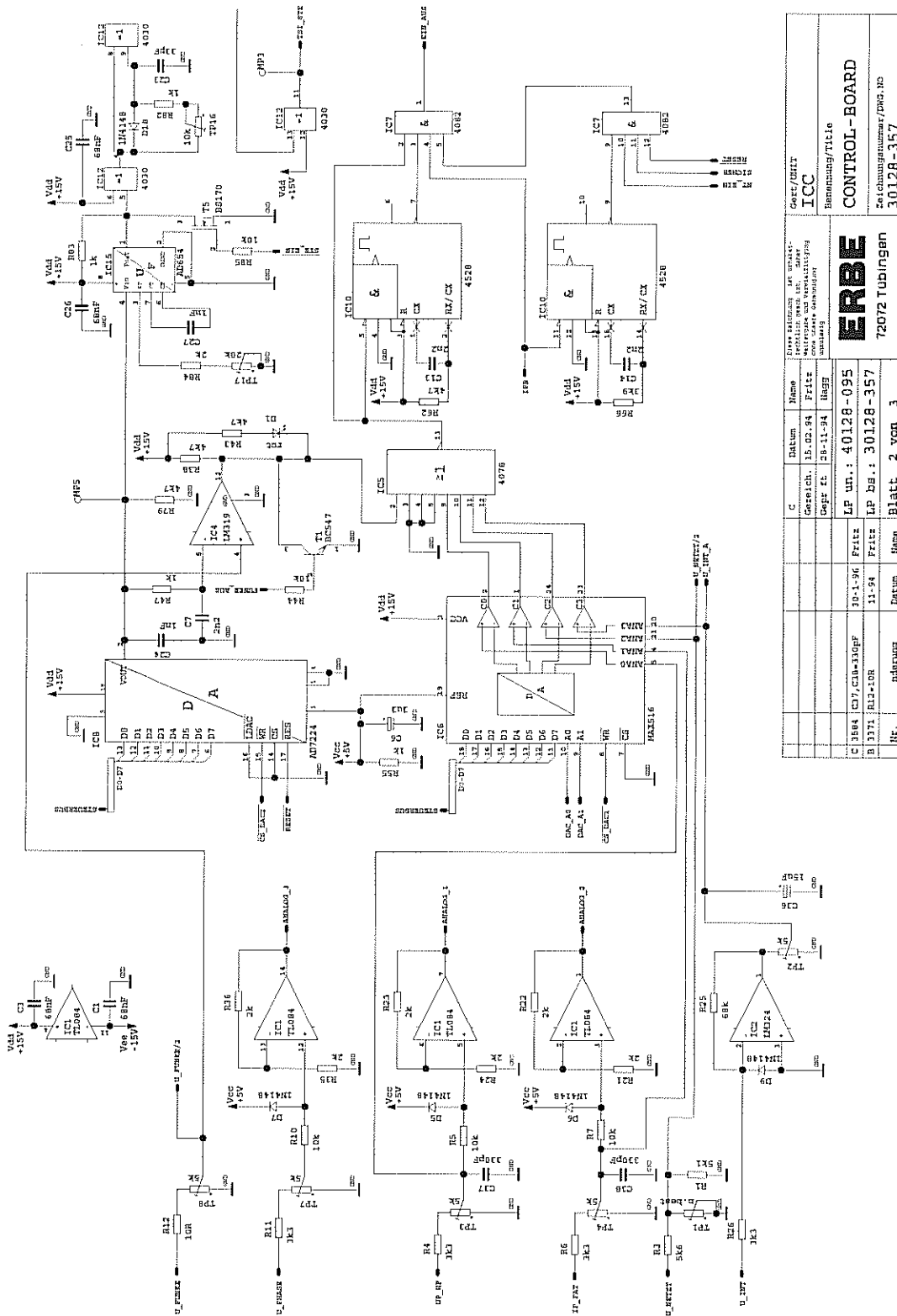

ICC 200, 300, 350

Control board 30128-357

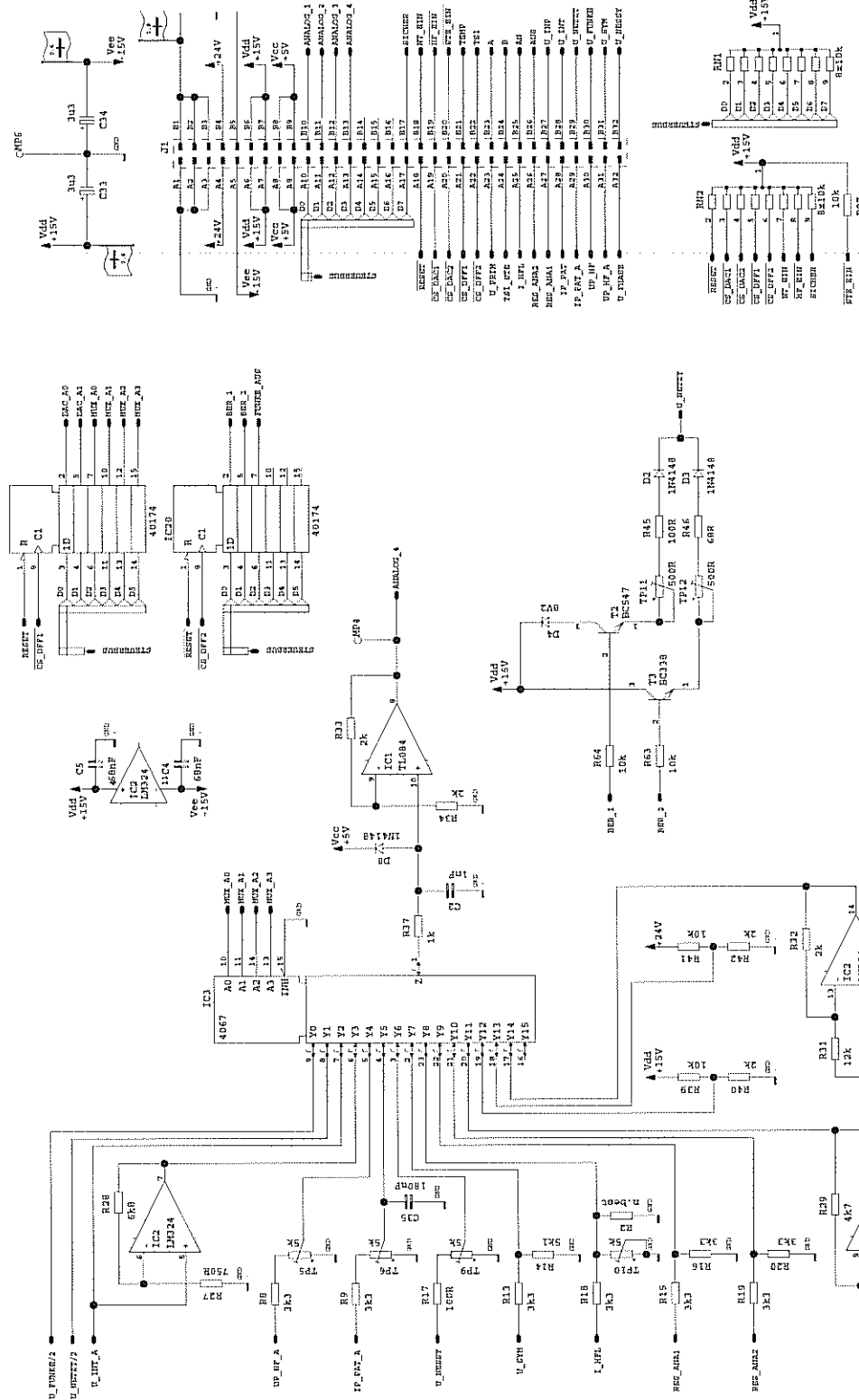

Gez./HNT ICC		Bezeichnung/Tabelle CONTROL-BOARD	
Zuschussnummer/DWG.Nr. 30128-357			
Blatt 3 von 3			
IP nr.: 40128-095			
IP 1-96 Fritz			
IP 11-94 Fritz			
Datum			
Änderung			
Name			
Nr.			

Blatt 3 von 3	
IP nr.: 40128-095	
IP 1-96 Fritz	
IP 11-94 Fritz	
Datum	
Änderung	
Name	
Nr.	

Art. No. 60116-201
09/2004

ICC 200, 300, 350

Control board (bare)

40128-095

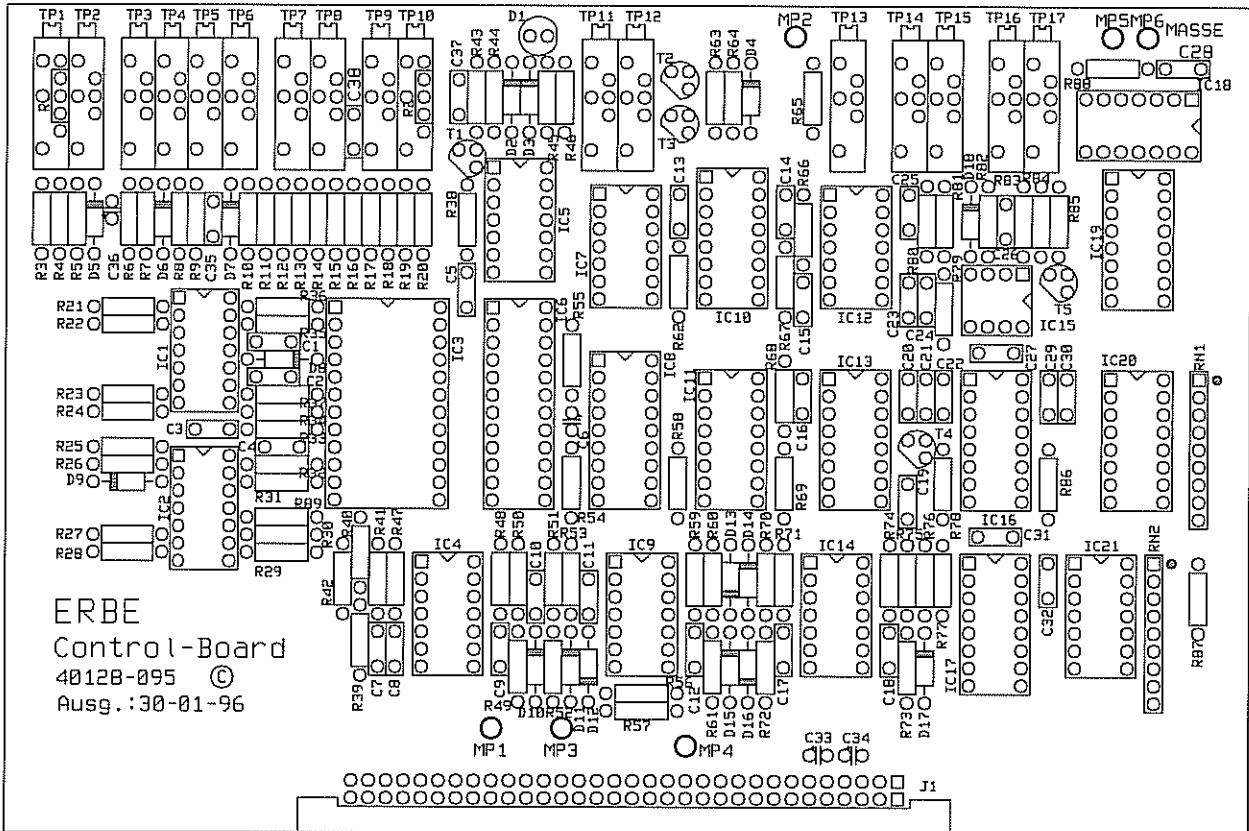

CONTROL-BOARD
40128-095
30-01-96

ICC 200, 300, 350

QC Power Stage 30128-528

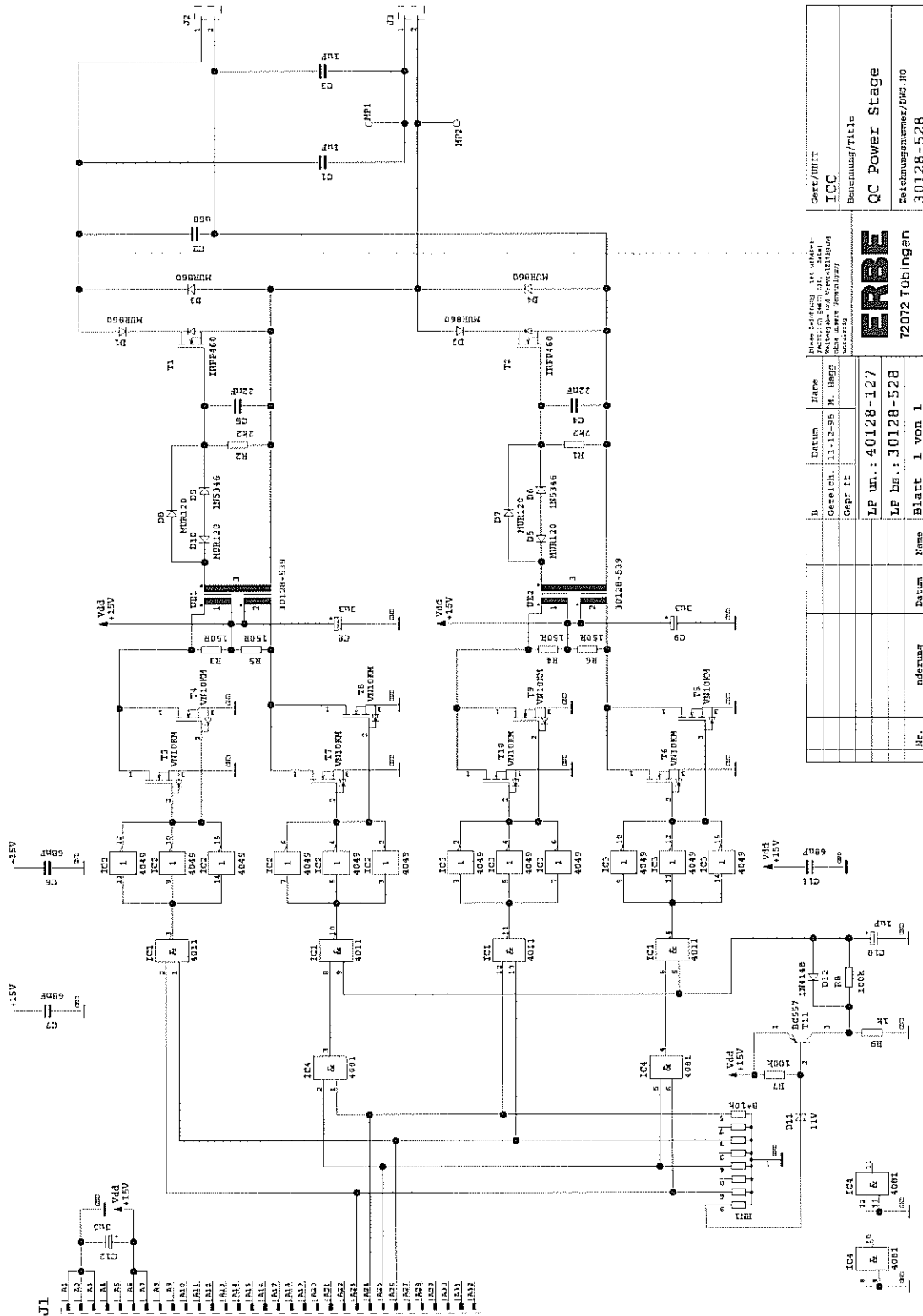

Platzbezeichnung des Bauelementes Bezeichnung des Bauelementes Werte		Gez./limit ICC	
B		Benennung/Title QC Power Stage	
Datum		Zeichnungsnummer/DWG.-Nr. 30128-528	
Gezeichnet: 11.12.95 H. Hupp		72072 Tübingen	
Gepr. It.		ERBE	
LP un.: 40128-127			
LP Nr.: 30128-528			
Blatt 1 von 1			
Nr.	Änderung	Datum	Mens

Art. No. 80116-201
09/2004

ICC 200, 300, 350

QC Power Stage (bare)

40128-127

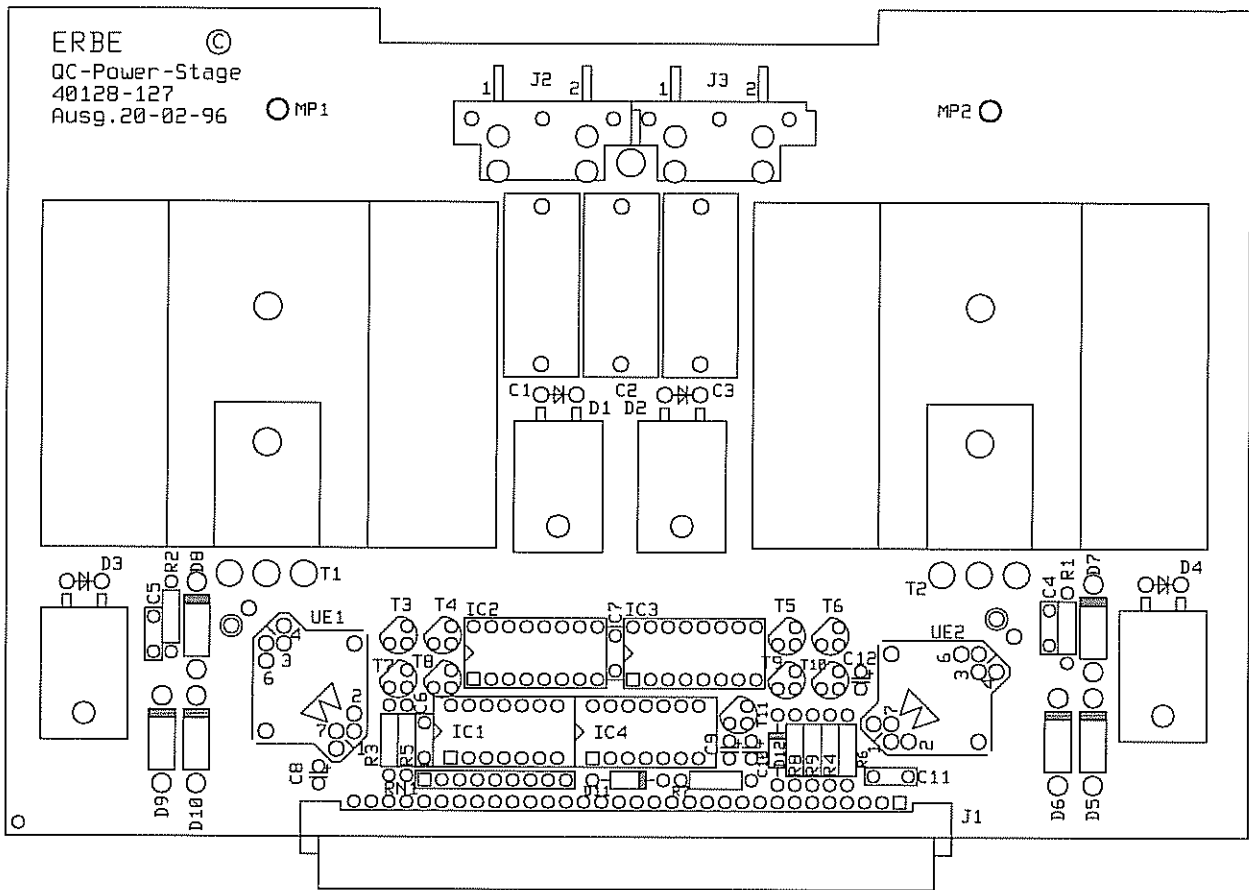

QC Power Stage
40128-127
19-11-97

ICC 200, 300, 350

Power Module 30128-478 Power Module (UL) 30128-492

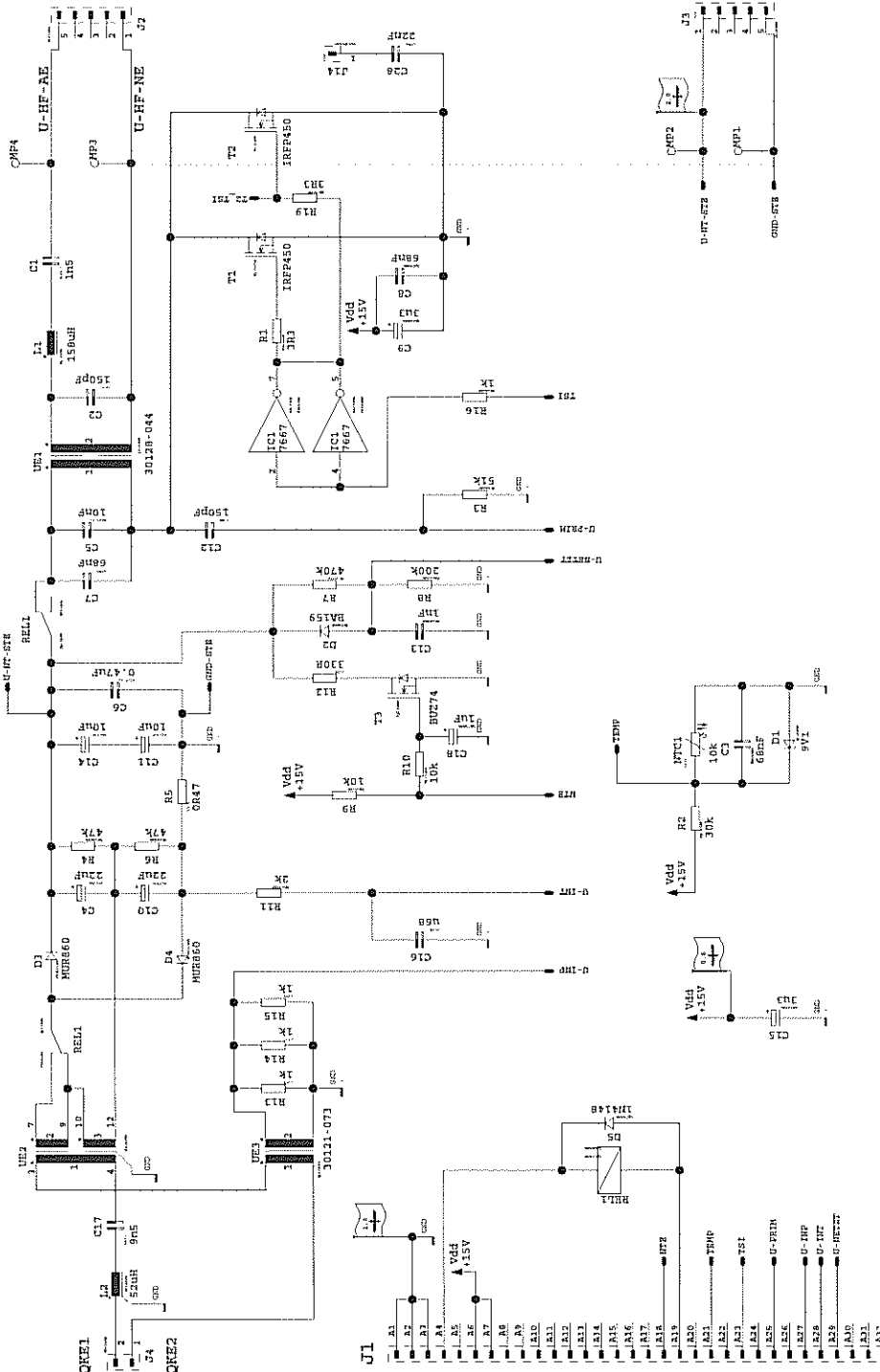

D	19-11-97	Datum	19-11-97	Gez./UNIT	ICC
IP un.:	40128-117	IP un.	40128-117	Benennung/Title	Power-Module
D 3696	in Änderungsst. 22-1-96	D	3696	rechenungsnummer/DWG.NR	30128-478
C 3570	in Änderungsst. 17-7-95	C	3570		
Blatt	1 von 1	Blatt	1 von 1		
ERBE 72072 Tübingen					
Diese Zeichnung ist ohne Gewähr für die Richtigkeit der Dimensionen und Verhältnisse. Diese Zeichnung ist ohne Gewähr für die Richtigkeit der Dimensionen und Verhältnisse.					

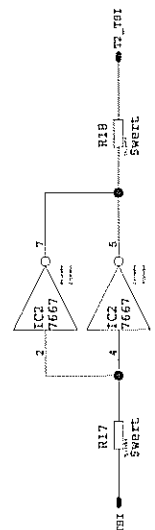

Art. No. 80116-201
09/2004

ICC 200, 300, 350

Power Module (bare)
Power Module UL (bare)
40128-117

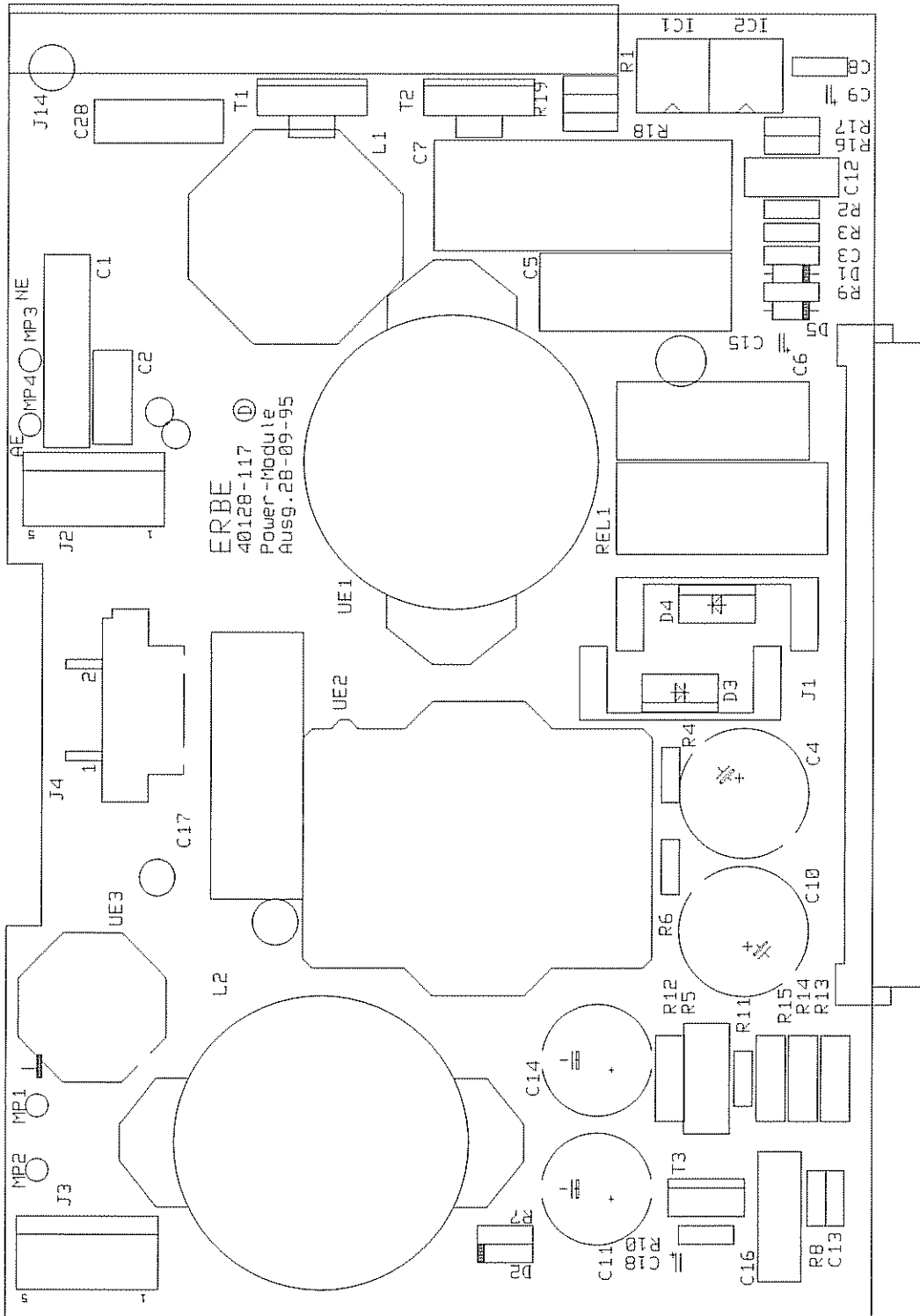

Power-Module
40128-117
19-11-97

ICC 200, 300, 350

ST Power Stage 30128-555

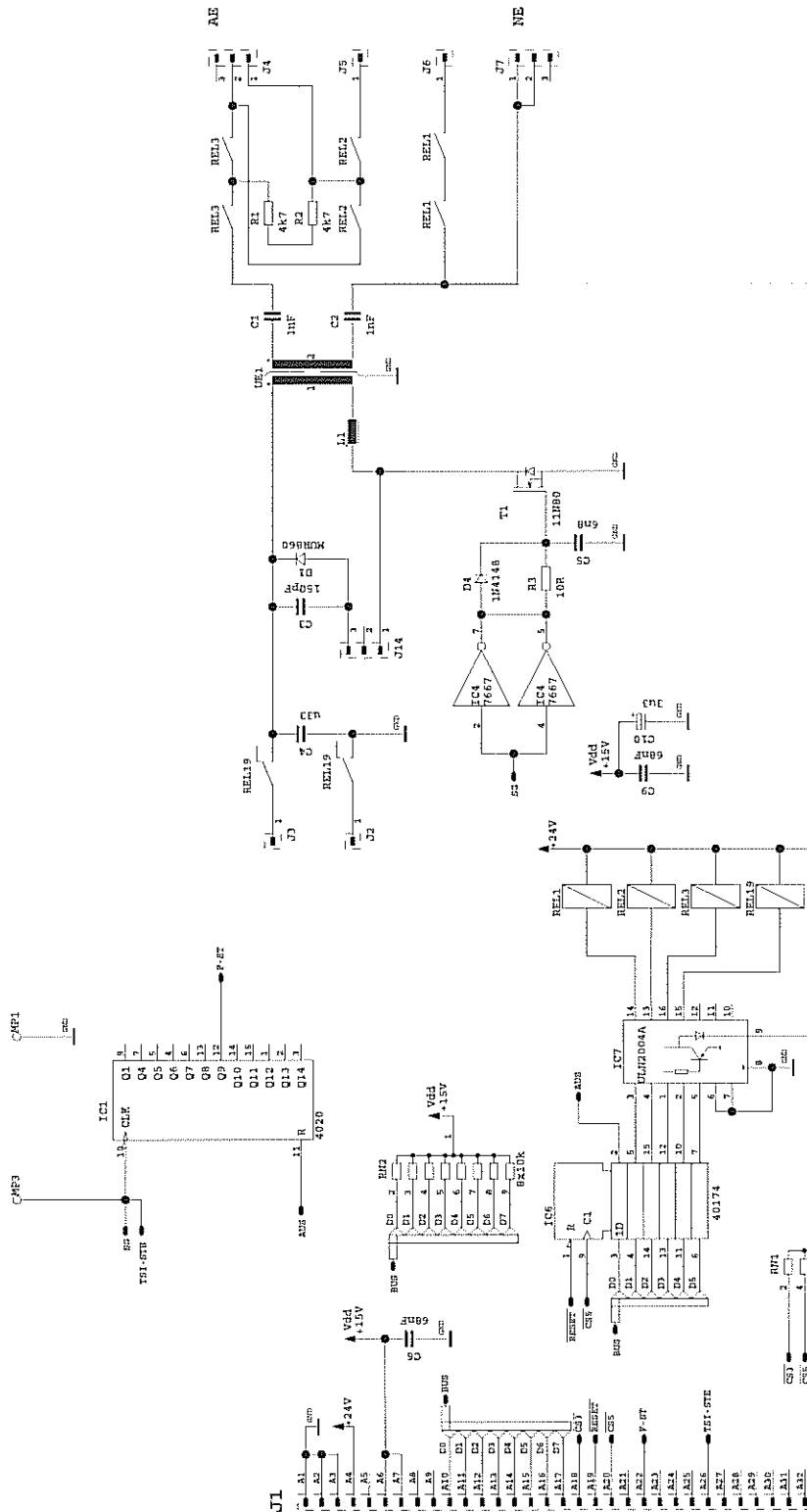

D	Datum	Name	Rev.
	15-03-96	M.Fritze	
		Gepr. ft.	
		LP un. : 40128-129	
		LP bs. : 30128-555	
B	12-9-96	Fritze	
		Änderung	
		Blatt 1 von 1	

Diese Zeichnung ist urheberrechtlich geschützt durch die Erbe Industrie AG. Alle Rechte vorbehalten.	
Gepr./Prüf.	ICC
Benennung/Title	ST-Power-Stage
Zeichnungsnummer/DWG. NO	30128-555
ERBE	
72072 TUBINGEN	

Art. No. 60116-201
09/2004

ICC 200, 300, 350

ST Power Stage (bare)

40128-129

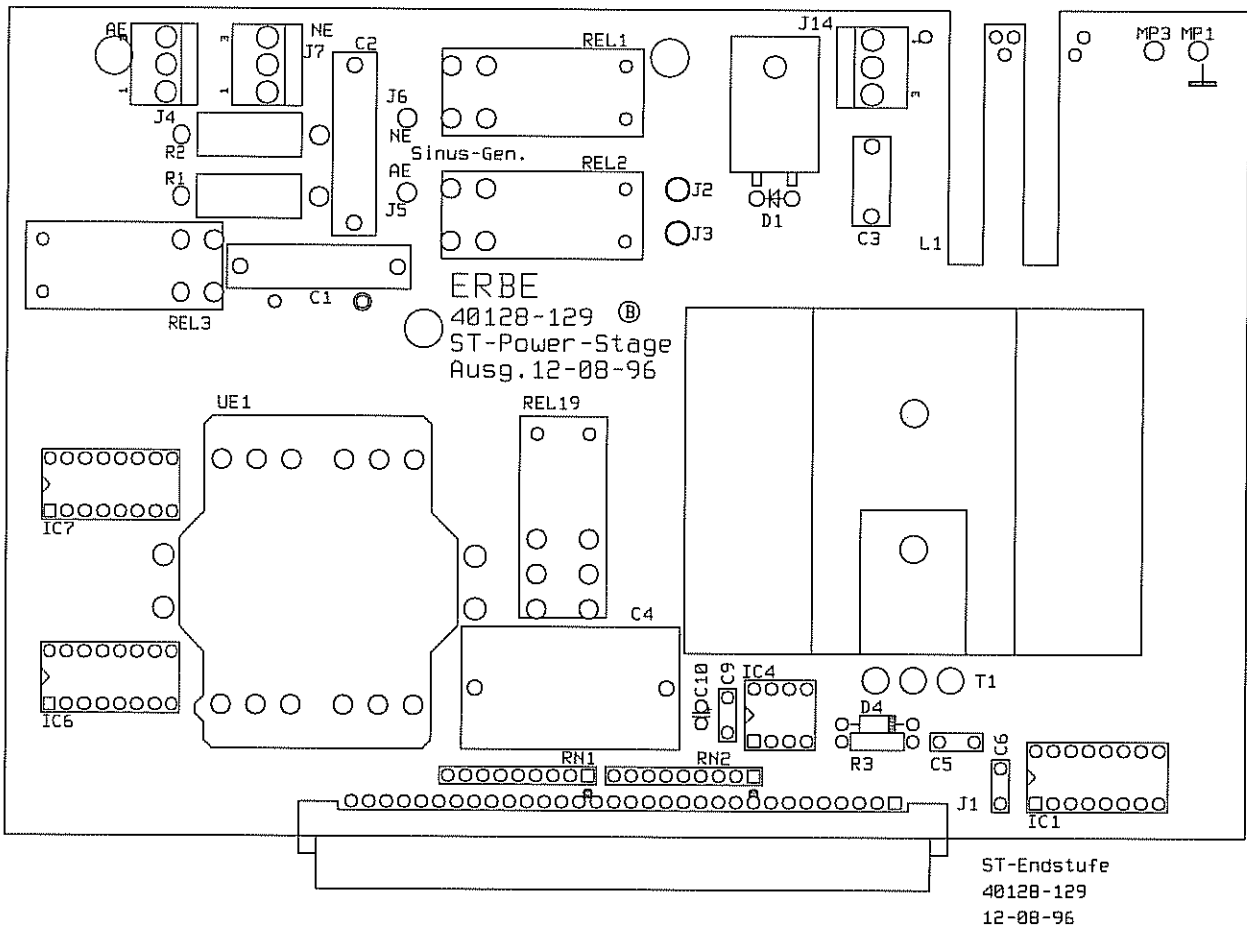

ICC 200, 300, 350

Senso-board 30128-561

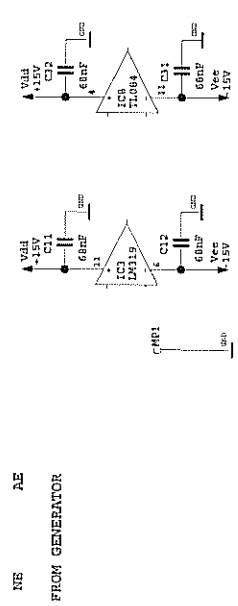
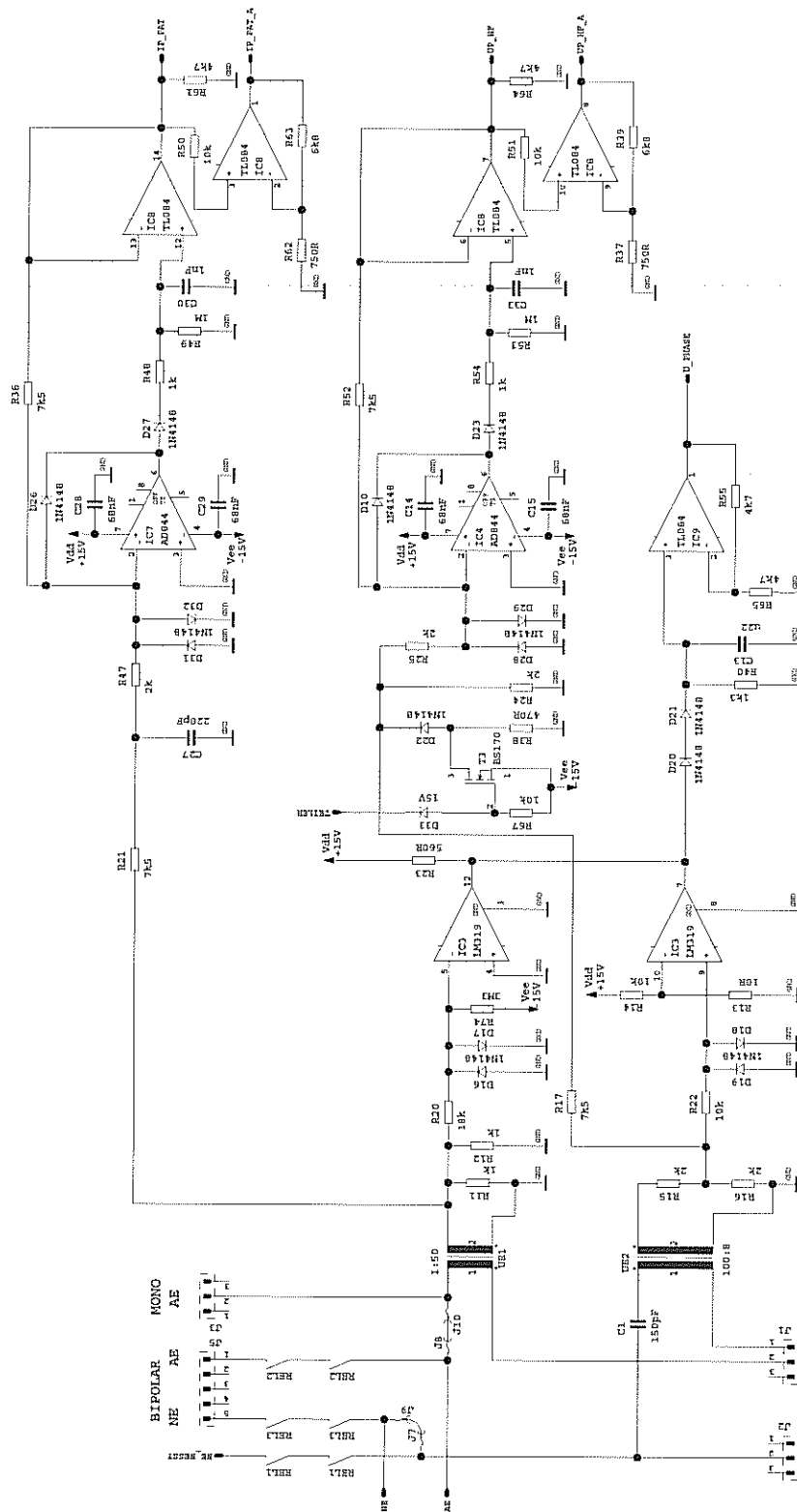

Gez./UNIT		Benennung/Title	
ICC		SENSO-BOARD	
Zeichnungsnummer/Draw. No.		30128-561	
ERBE			
72072 Tübingen			
Blatt	von	U.P. Nr.	U.P. Nr.
1	3	40128-130	30128-561
Datum	Name	Datum	Name
12.08.95	Prüfer	13.1.98	Prüfer
12.08.95	Prüfer	13.1.98	Prüfer
Erbe Elektronik, 1st. Klasse Multiple- und Hybridtechnik (Schulabteilung)			

Art. No. 80116-201
08/2004

ICC 200, 300, 350

Senso-board 30128-561

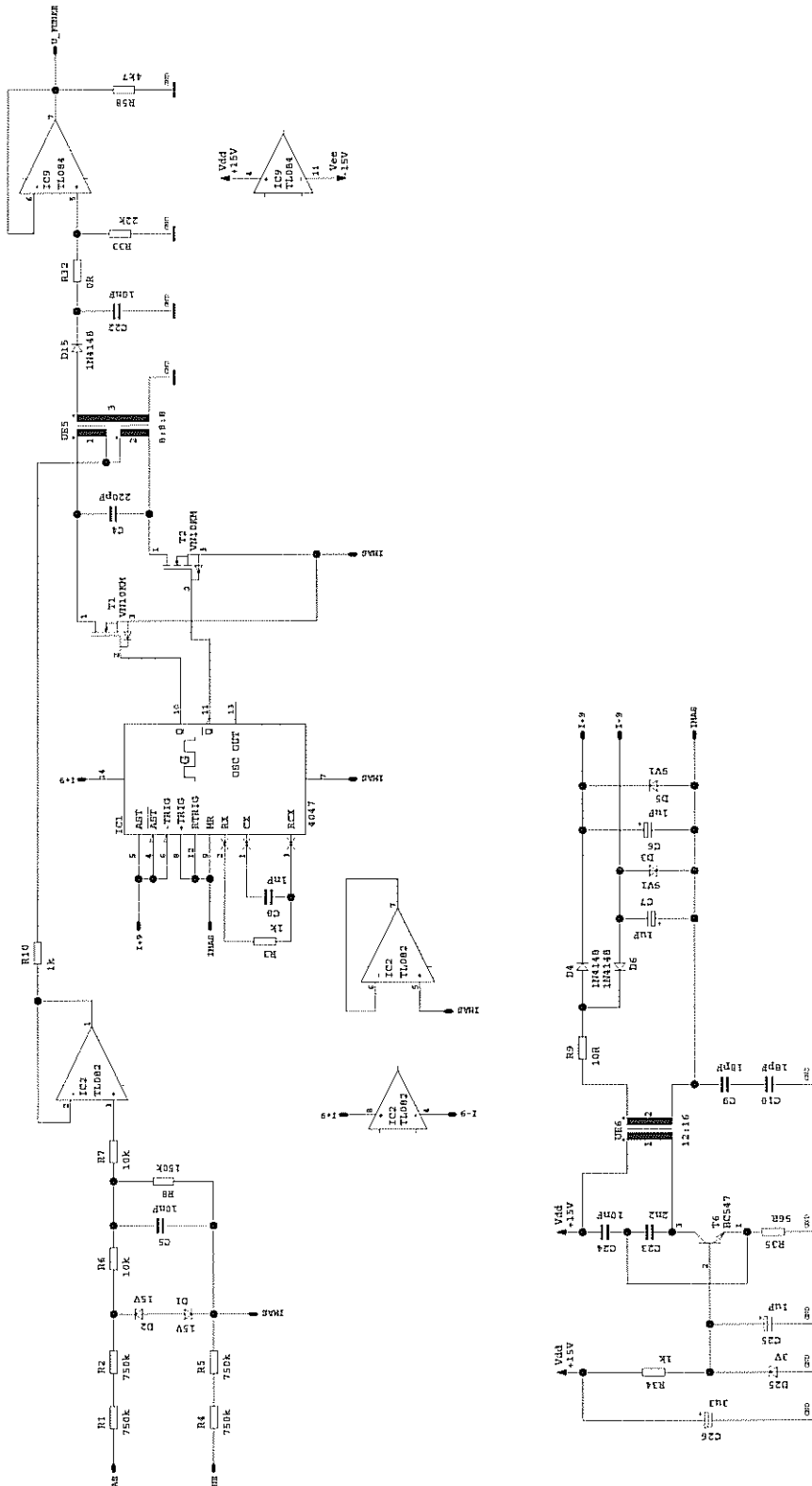

Best/DHIT ICC		Bestandteile mit ungerader Wertigkeit sind veraltet Wertigkeit und Veraltungszeit sind in der Baugruppe angegeben		Bestandteile IC1 IC2 IC3 IC4 IC5 IC6 IC7 IC8 IC9 IC10 IC11 IC12 IC13 IC14 IC15 IC16 IC17 IC18 IC19 IC20 IC21 IC22 IC23 IC24 IC25 IC26 IC27 IC28 IC29 IC30 IC31 IC32 IC33 IC34 IC35 IC36 IC37 IC38 IC39 IC40 IC41 IC42 IC43 IC44 IC45 IC46 IC47 IC48 IC49 IC50 IC51 IC52 IC53 IC54 IC55 IC56 IC57 IC58 IC59 IC60 IC61 IC62 IC63 IC64 IC65 IC66 IC67 IC68 IC69 IC70 IC71 IC72 IC73 IC74 IC75 IC76 IC77 IC78 IC79 IC80 IC81 IC82 IC83 IC84 IC85 IC86 IC87 IC88 IC89 IC90 IC91 IC92 IC93 IC94 IC95 IC96 IC97 IC98 IC99 IC100	
Benennung/Titel SENSO-BOARD		ERBE		72072 TUDINGEN	
Zeichnungsnummer/DWG.NR. 30128-561		LP un. : 40128-130		LP lb. : 30128-561	
		Blatt 2 von 3			
		Name		datum	
		Mf.		Mf.	

ICC 200, 300, 350

Senso-board (bare)

40128-130

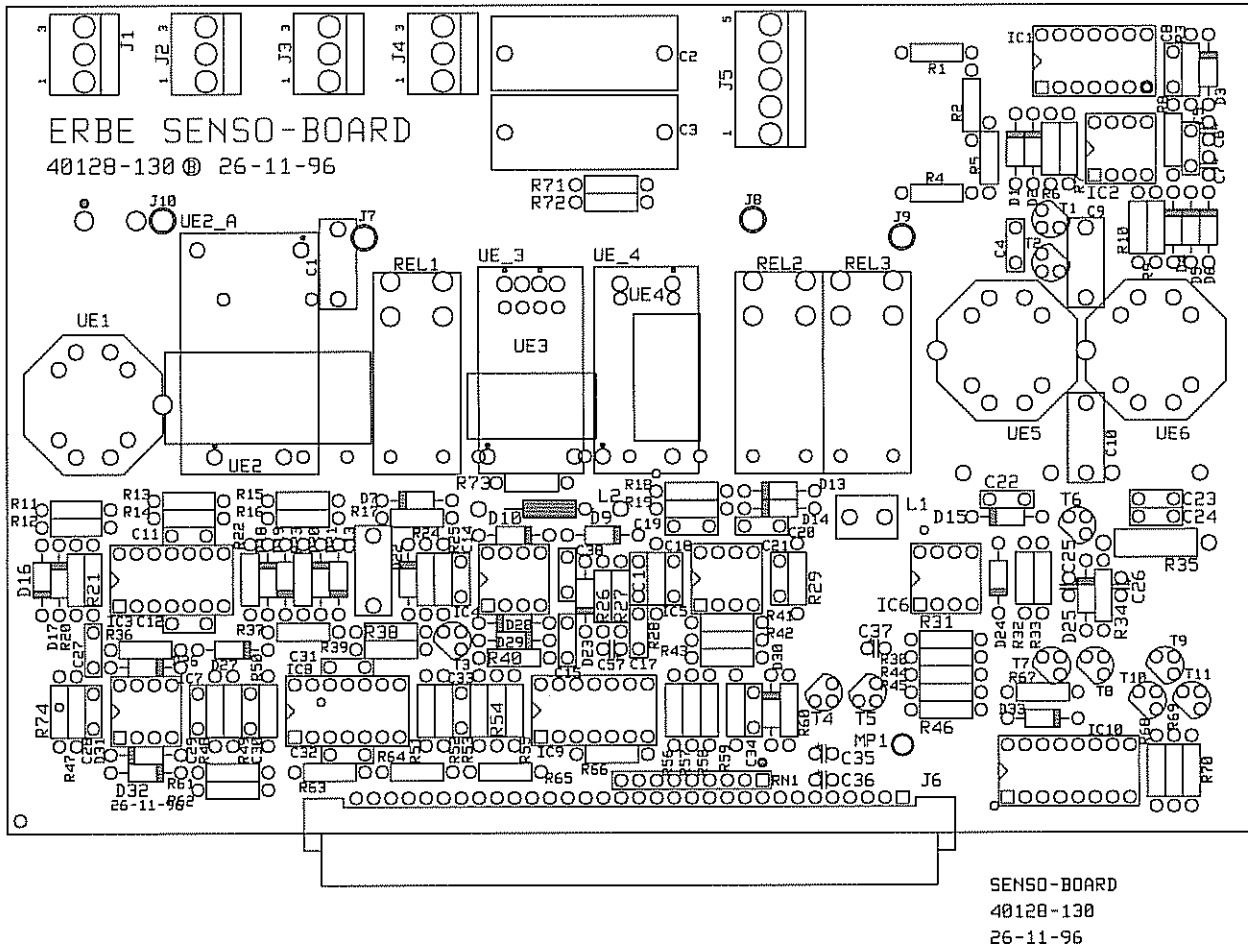

ICC 200, 300, 350

Upper Wiring Module 30128-479

Art. No. 80116-201
08/2004

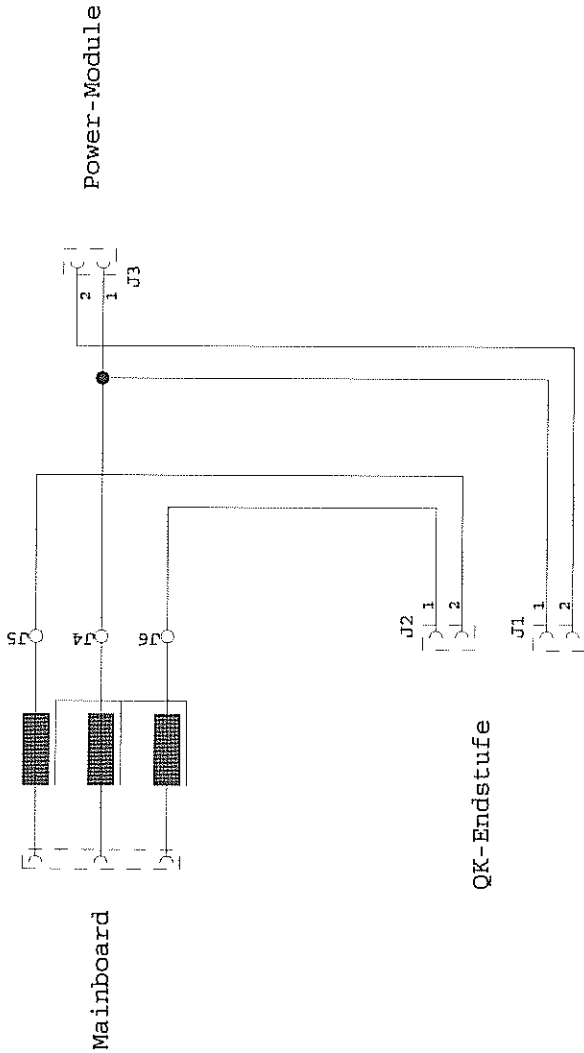

A		Name		Gert/UNIT	
Gezeich.		Datum		ICC	
Gepr ft		17-05-95		Benennung/Title	
LP un.:		M.Fritz		Upper Wiring Module	
LP bs.:		M.Hagg		Zeichnungsnummer/DWG.NO	
Blatt 1 von 1		40128-118		30128-479	
nderung		30128-479			
Datum		17-05-95			
Name		ERBE			
		7400 Tübingen			
		Diese Zeichnung ist urheberrechtlich gesch tzt, daher Weitergabe und Vervielfltigung ohne unsere Genehmigung unzulssig			

ICC 200, 300, 350

Upper Wiring Module (bare) 40128-118

Upper Wiring Module
40128-118
17-05-95

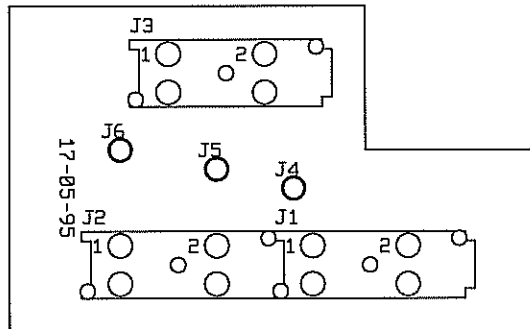

.....PCBs
only or CC200

ICC 200

Motherboard 30128-033

Art. No. 80116-201
09/2004

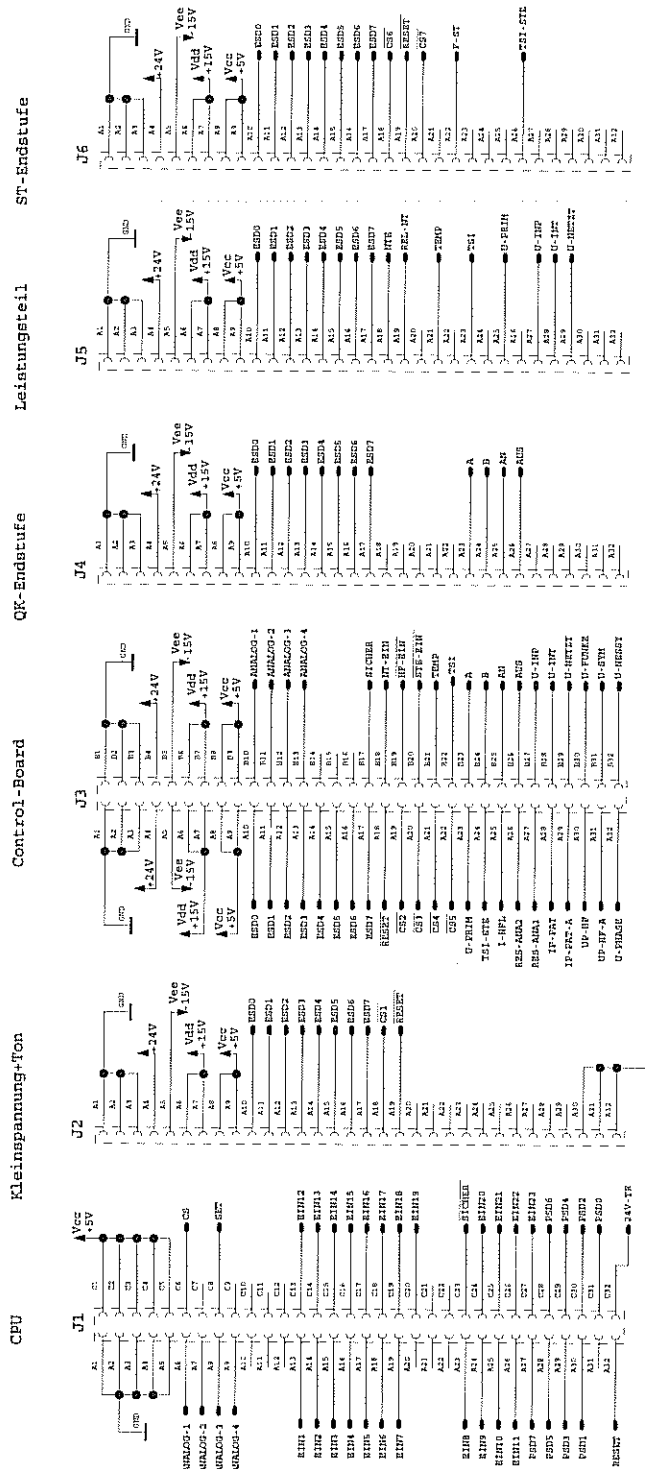

ICC 200

Motherboard 30128-033

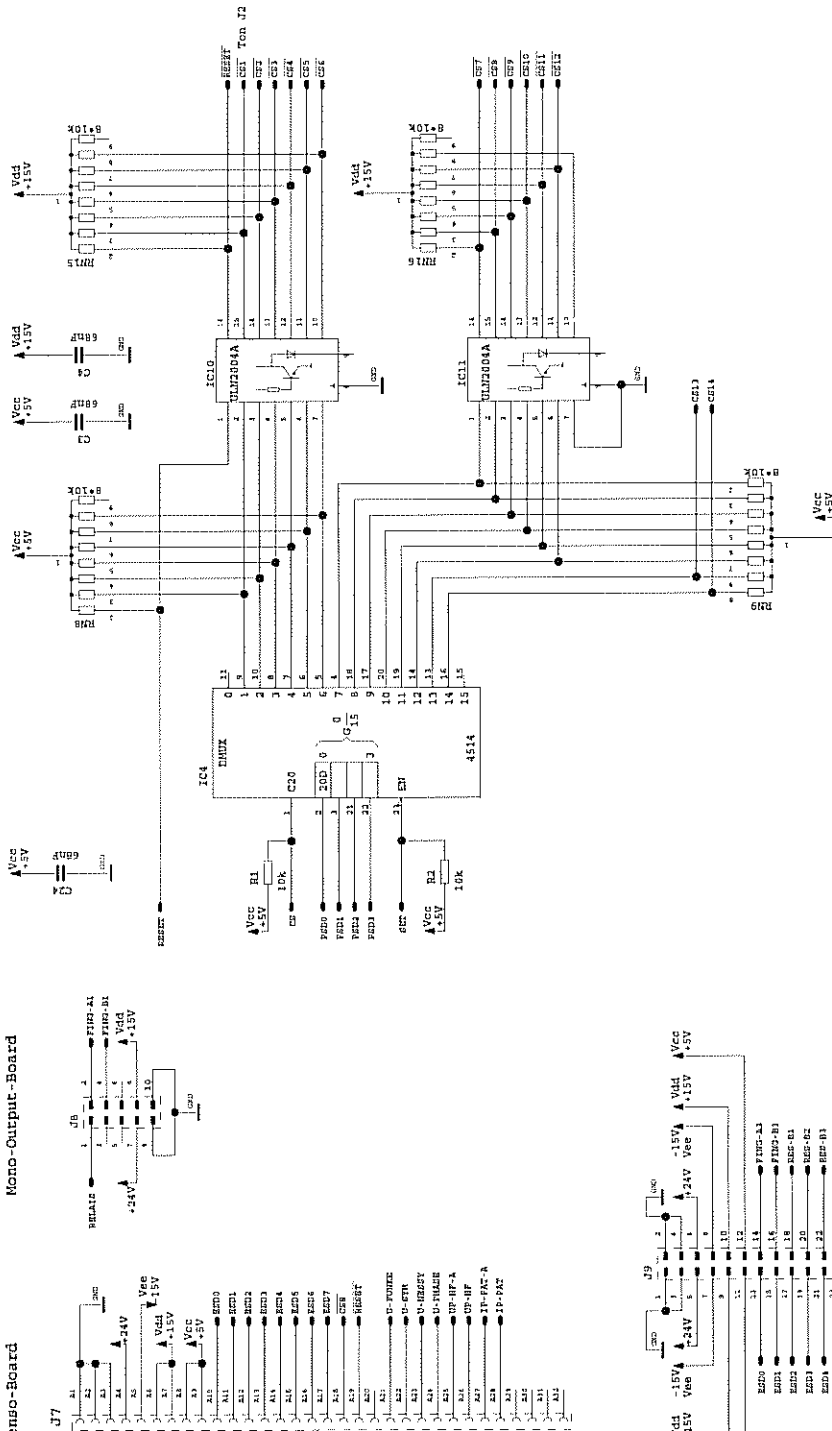

Diese Zeichnung ist urheberrechtlich geschützt durch Erbe 7400 Tübingen		Gez./URIT ICC 200	
B		Benennung/Title Motherboard 200	
Gez. dt.		Zeichnungsnummer/Dwg. Nr. 30128-033	
LP Nr.: 40128-025			
LP bs.: 30128-033			
Blatt 2 von 5			
RMI8-2K2			
8-93			
ME			
Datum		Name	
Nrn.		nderung	

ICC 200

Motherboard 30128-033

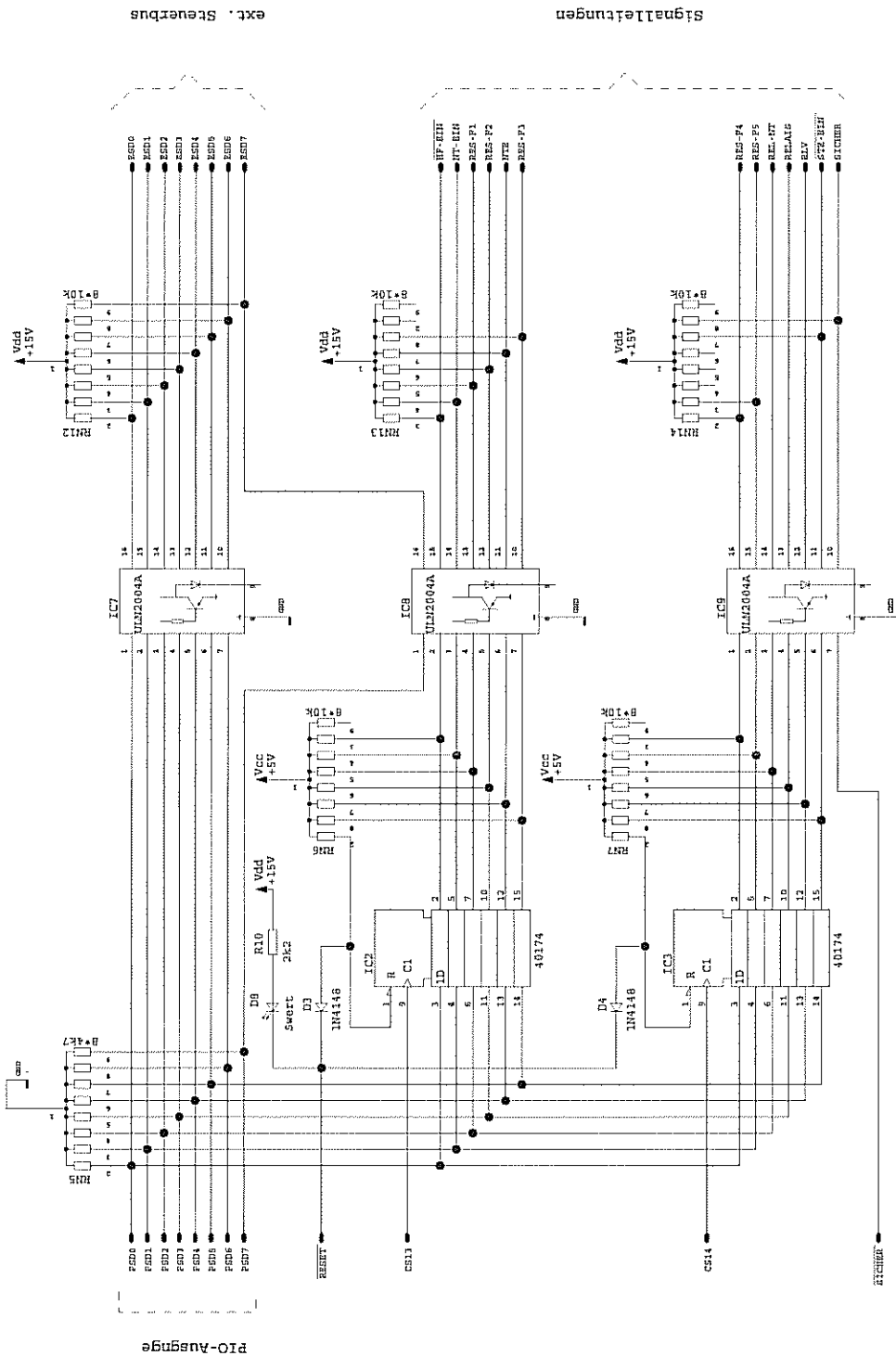

Name		Date	
Gert/UNIT		ICC 200	
Benennung/Title			
Motherboard 200			
Zeichnungsnummer/DWG. NO			
30128-033			
Diese Zeichnung ist unvollständig ohne Weitergabe und Vervielfältigung ohne unsere Genehmigung			
ERBE			
7400 TUBINGEN			
B	Datum	Name	
	25-05-92	M. Pfeifer	
Gezeichnet		Gepr. ft	
IP um.: 40128-025		IP bs.: 30128-033	
RH18=2K2	8-93	MF	
Nr.	nderung	Datum	Name
		Blatt 4 von 5	

ICC 200

Motherboard 30128-033

Art. No. 80116-201
08/2004

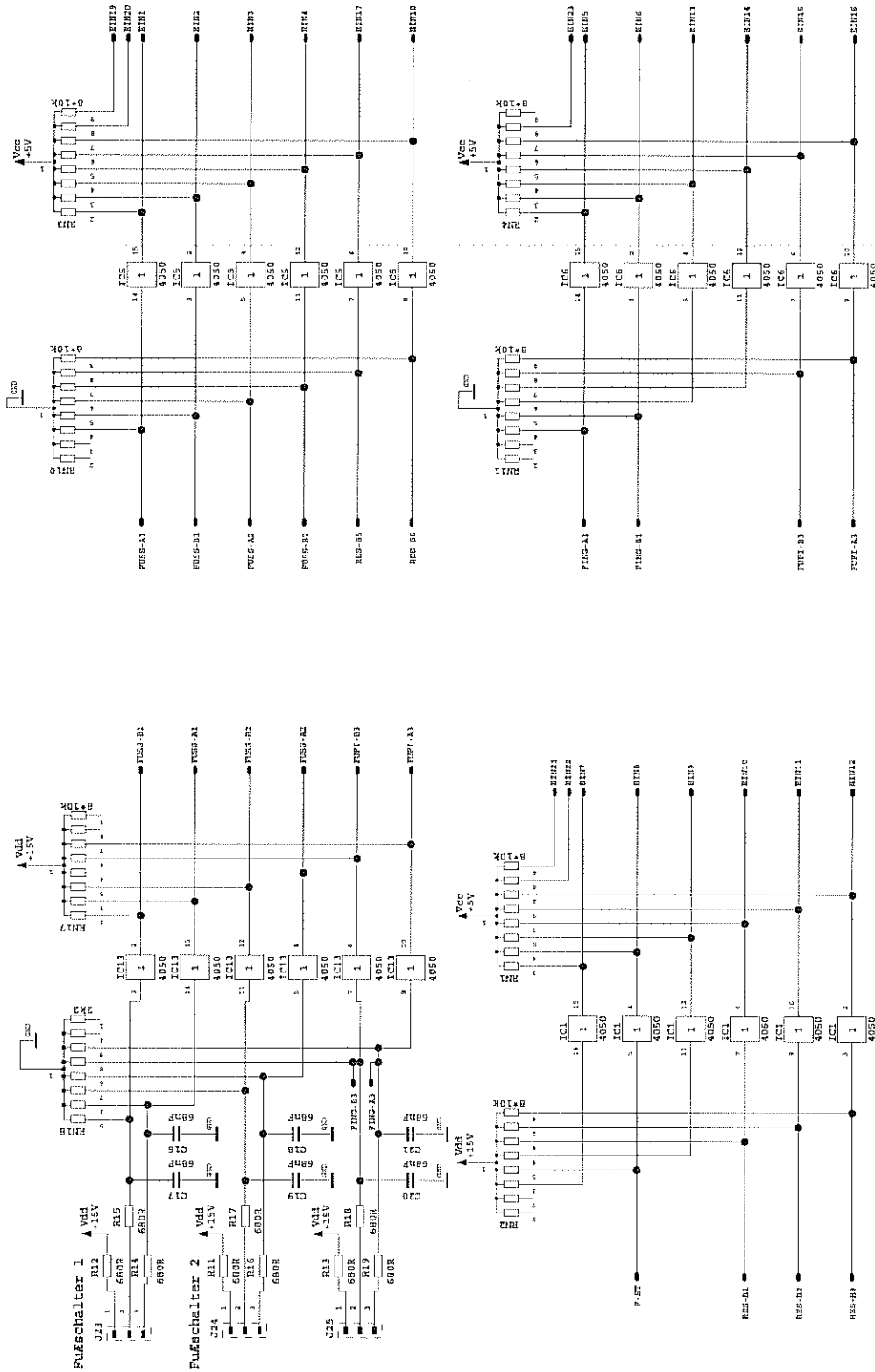

Gez./UNIT	
ICC 200	
Benennung/Title	
Motherboard 200	
Rechnungsnummer/DWG.Nr.	
30128-033	
ERBE	
7400 Tübingen	
Name	
M. Priller	
Datum	
25-05-93	
Gezeichnet	
M. Priller	
Geprüft	
M. Priller	
Name	
M. Priller	
Datum	
25-05-93	
LP un.	
40128-025	
LP bs.	
30128-033	
Blatt	
5 von 5	

ICC 200

Motherboard (bare) 40128-025

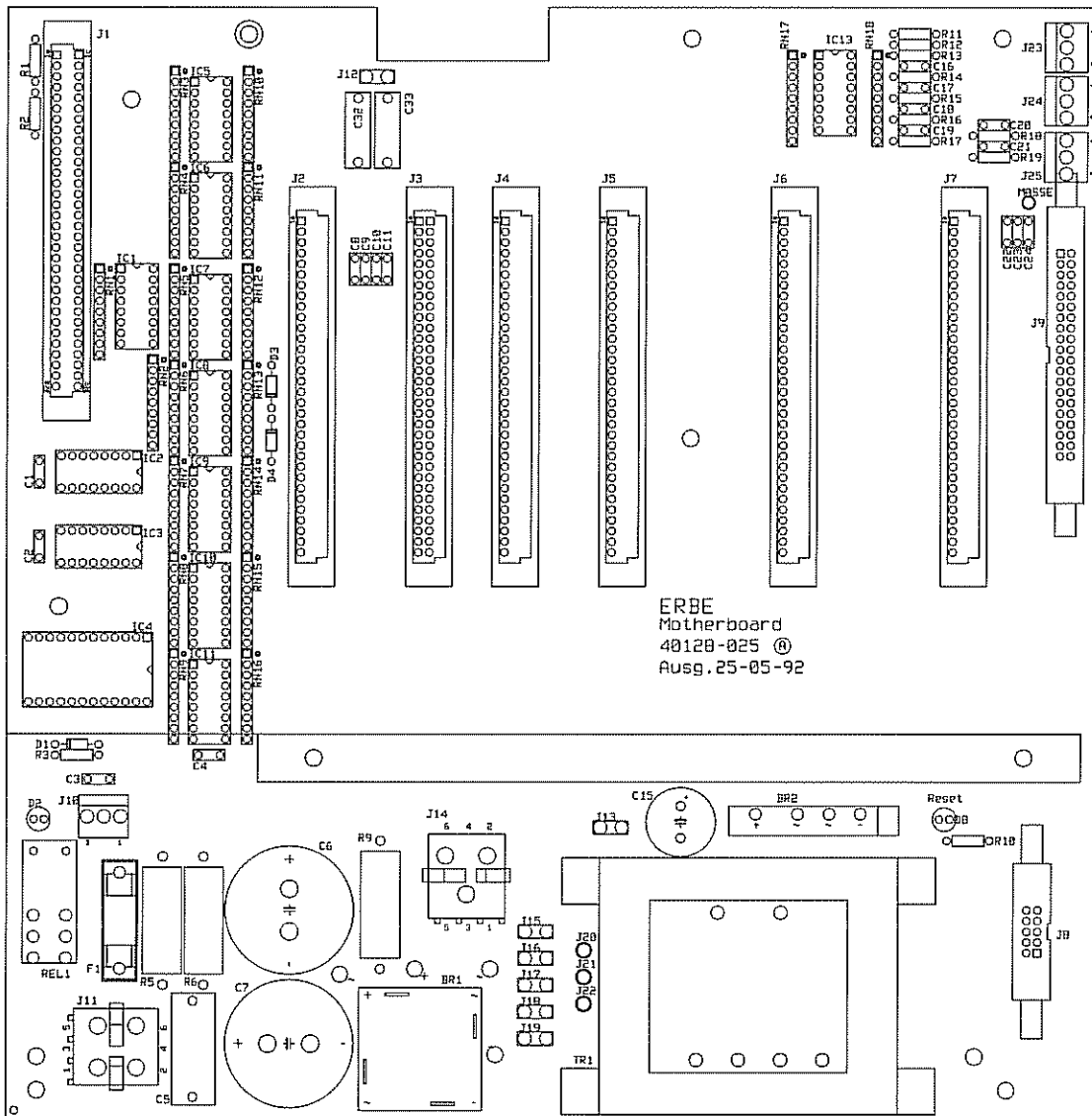

Motherboard 288
40128-025
10-01-95

ICC 200

Mono Output 30128-358

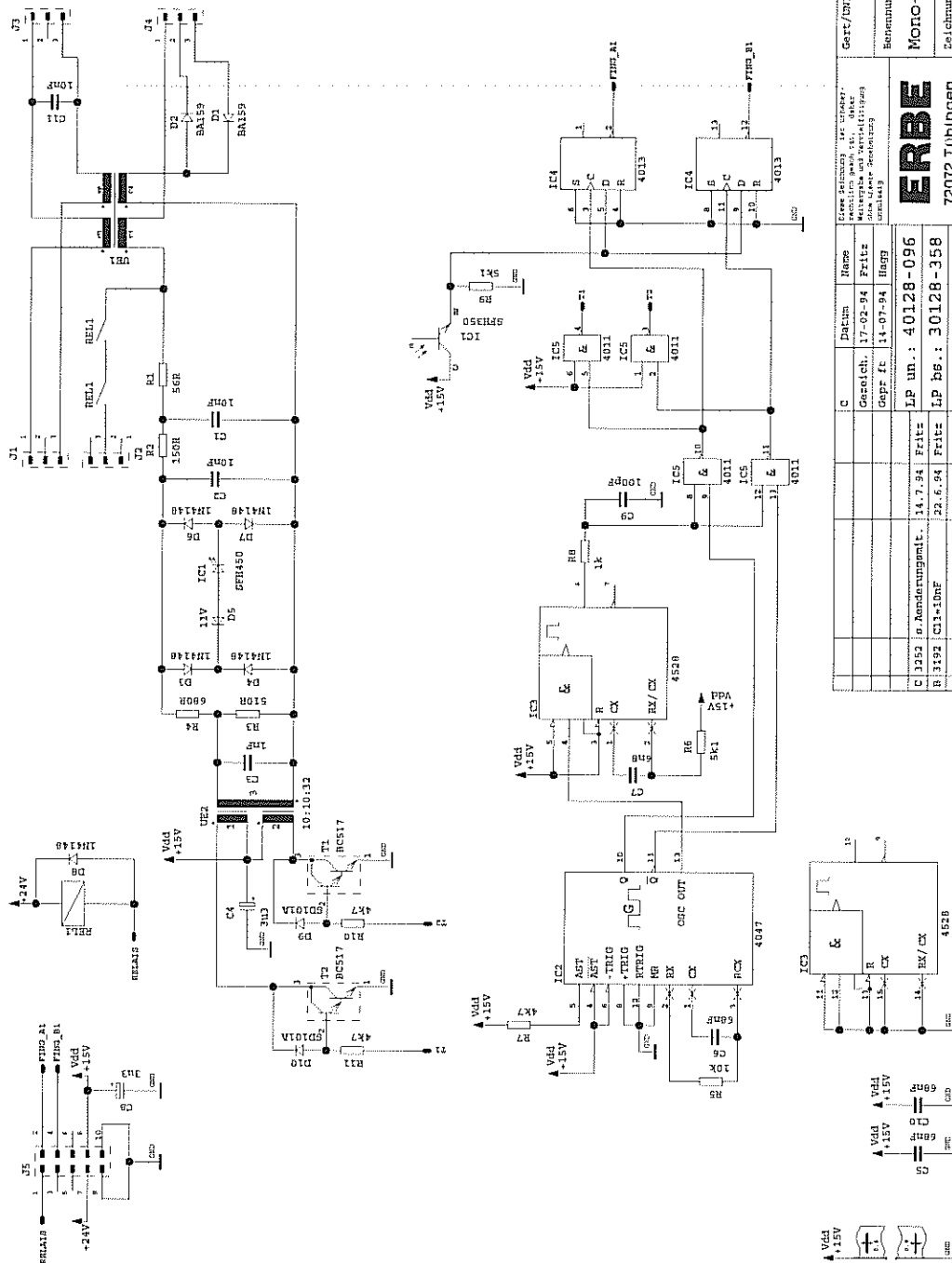

Art. No. 80116-201
09/2004

C		D		G		Gert./DNIT	
Gerätch.	17-02-94	Name	Fritz	ICC 200		Bezeichnung/Title	
Gepr. Ft.	14-07-94	Gepr. Ft.	Hggf	Mono-Output-Board		Zeilchennummer/DWG.-NO	
C 1352 d. Bauernungsmat.		14.7.94 Fritz		72072 Tübingen		30128-358	
R 1392 C13-10nF		22.6.94 Fritz		Blatt 1 von 1			
LP un.: 40128-096		LP bs.: 30128-358					
Br.		Mädung		Datum		Blatt	

ERBE
72072 Tübingen

ICC 200

Mono Output (bare)

40128-096

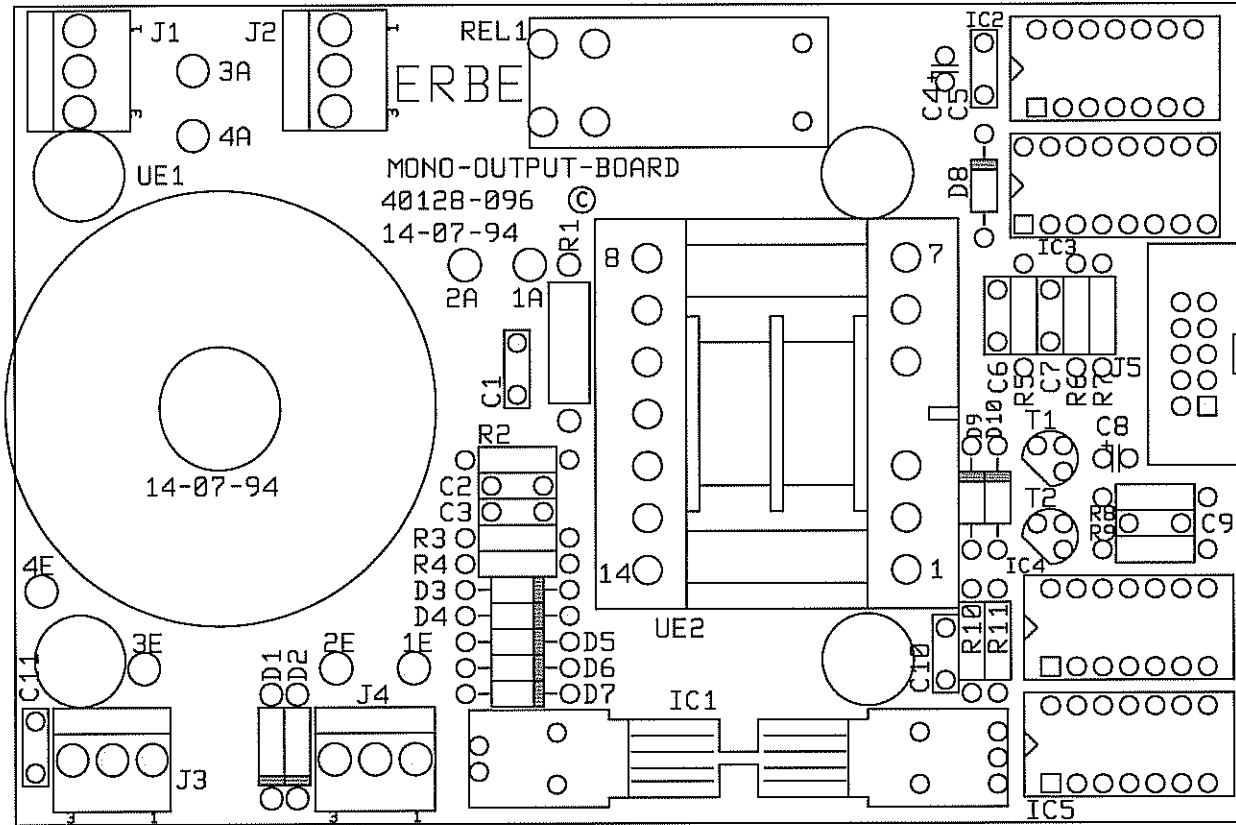

MONO-OUTPUT BOARD
40128-096
14-07-94

PCBs

only for ICC 300

ICC 300

Motherboard 30128-394

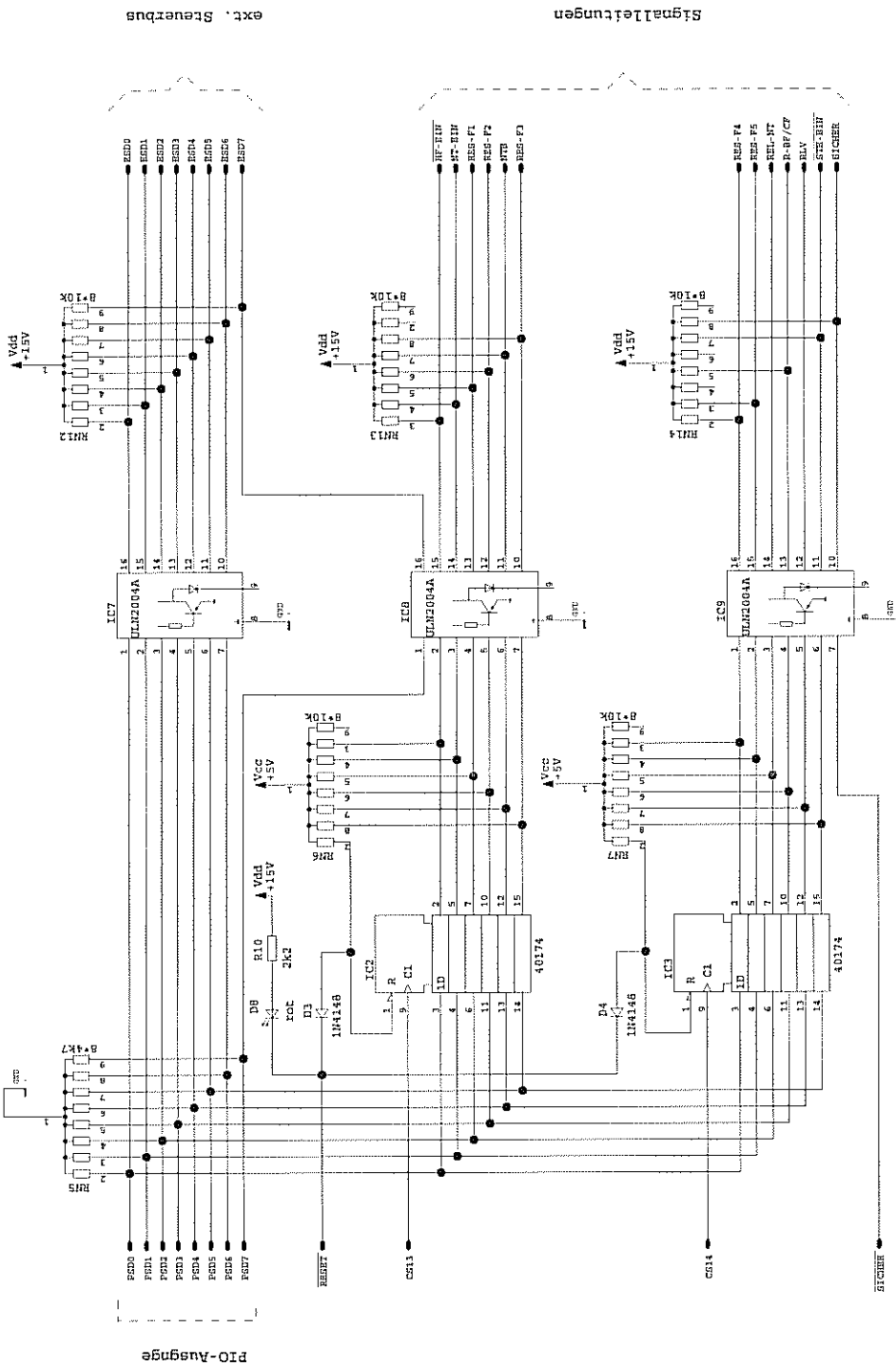

A		Datum		Name		Gezeichnet		Gepr. ft.		Innen-Abteilung		Geht./UNIT	
			20-07-94		M. Fritz		20-07-94		M. Hagg		IC300		IC300
						LP un.: 40128-092		LP bs.: 30128-394		Benennung/Titel		Motherboard	
Nr.		änderung		Datum		Name		Blatt 4 von 5		Beschreibungsnummer/Phg. No		30128-394	
										ERBE			
										72072 Tübingen			

ICC 300

Motherboard (bare)

40128-092

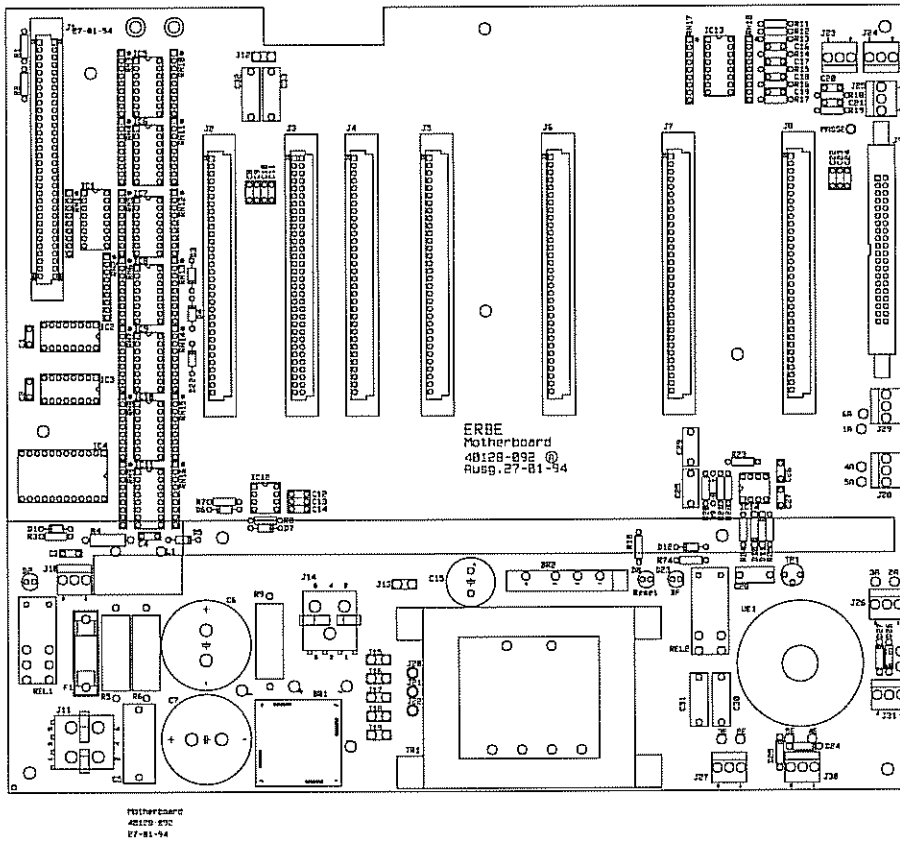

ICC 300

Relay Board 30128-352

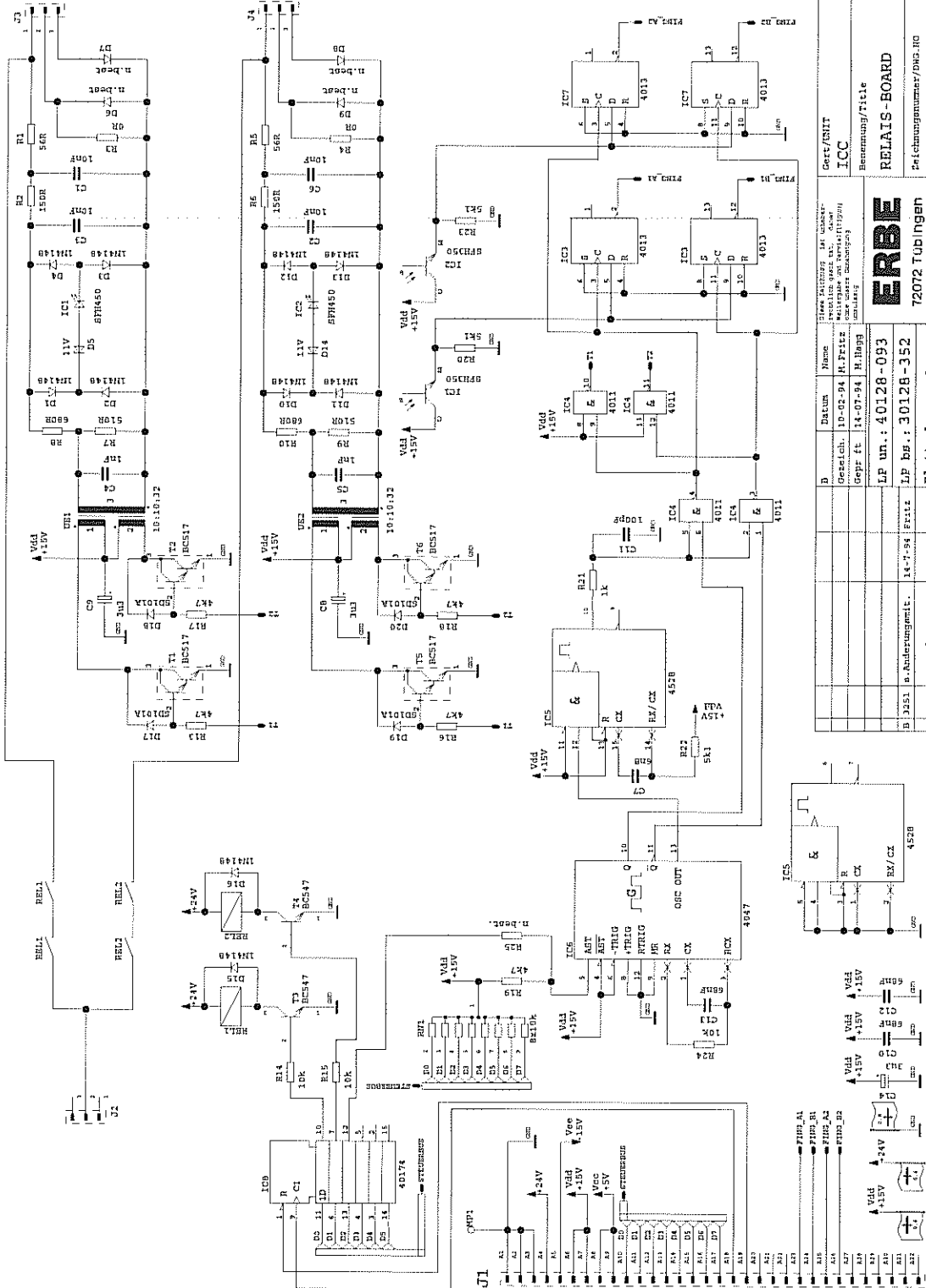

Getz/ENIT	ICC
Berechnung/Title	RELAIS-BOARD
Zeichnungsnummer/Proj. NO	30128-352
Hersteller	ERBE
Werk	72072 TUBINGEN
LP un.:	40128-093
B. 1251 a. Änderungsmitt.	14-7-94 Fritz
LP bb.:	30128-352
Blatt	1 von 1
Prüfung	
Datum	
Name	
Gezeichnet	10-02-94 H. Fritz
Geprüft	14-07-94 H. Fritz
Gezeichnet	
Geprüft	

Art. No. 80116-201
09/2004

ICC 300

Relay Board (bare) 40128-093

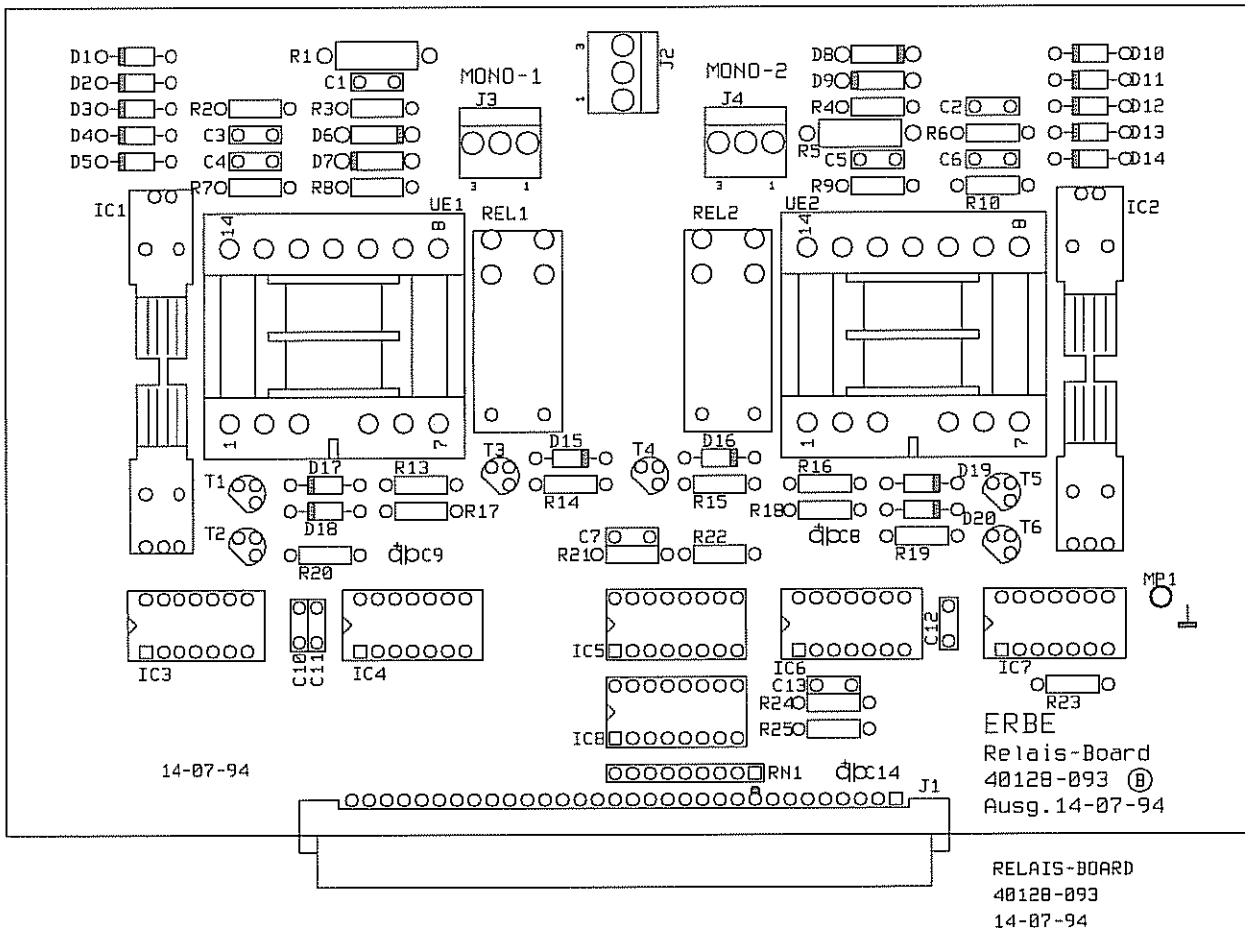

POSS

only for ICC 500

Motherboard 30128-351

Art. No. 80116-201
09/2004

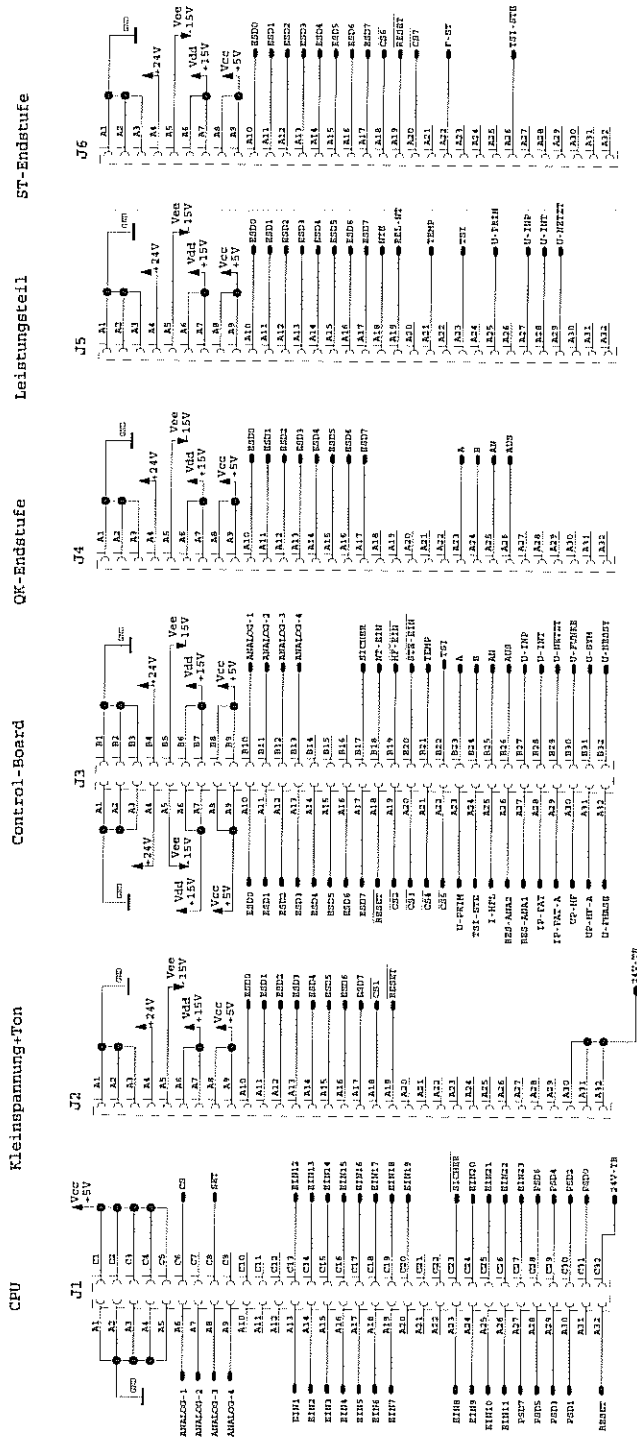

ICC 350

Motherboard 30128-351

Art. No. 80116-201
09/2004

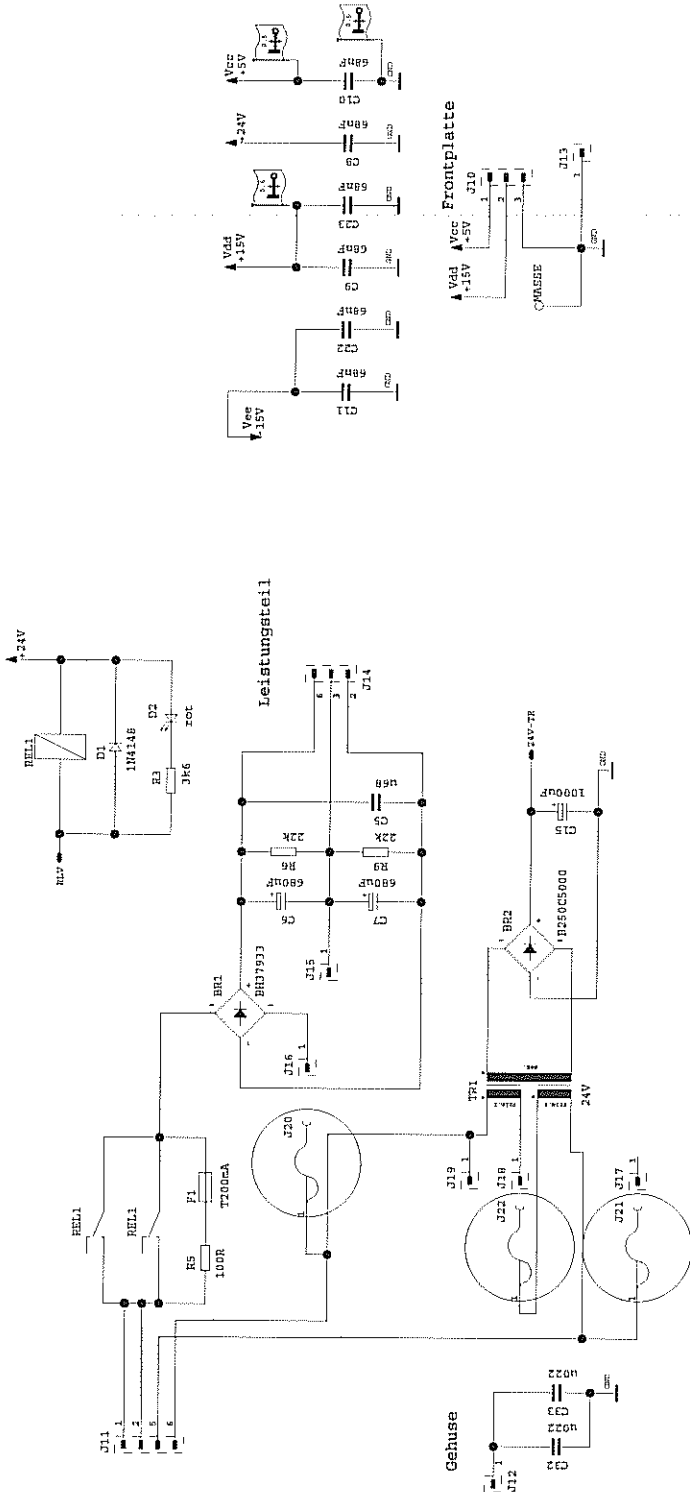

A	Datum	Name	Gez. Nr.	Gez. ft.	LP un.:	LP bs.:	Blatt	Name	Datum	Änderung
	27.01.94	M. Fritze		20-07-94	M. Hagg		3 von 6			
Diese Zeichnung ist urheberrechtlich geschützt durch ERBE. Jede Vervielfältigung ohne schriftliche Genehmigung ist strafbar.										
ERBE 72072 Tübingen										
Gez./URHT ICC Benennung/Title Motherboard Zeichnungsnummer/DRG.NR. 30128-351										

ICC 350

Motherboard 30128-351

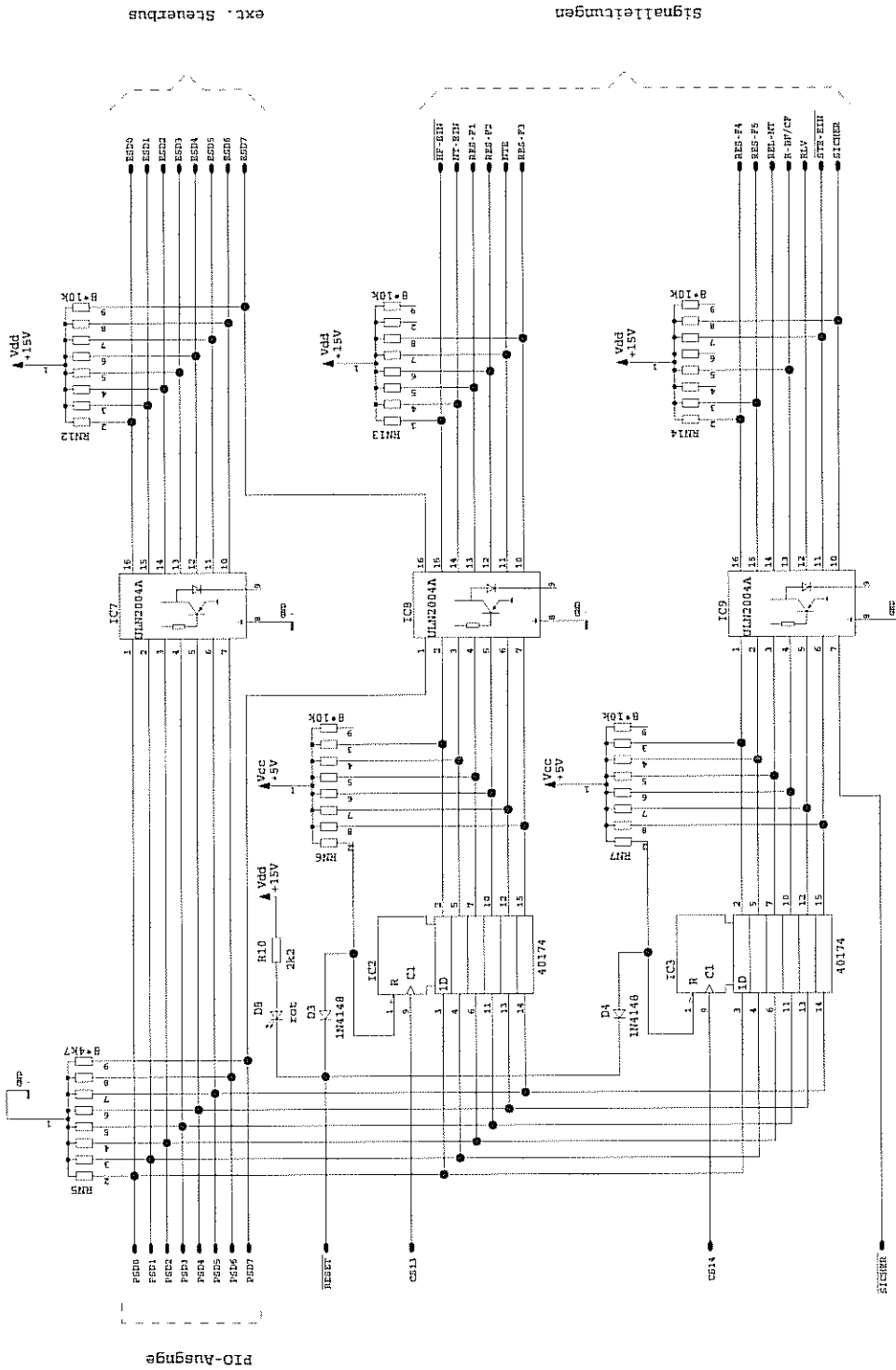

Gerät/UNIT ICC		Datei/Name Motherboard	
Benennung/Titel Motherboard		Zeichnungsnummer/DWG.-NO. 30128-351	
Erbe ist Lieferant und Hersteller dieses Produktes und übernimmt die Verantwortung für die Qualität dieses Produktes. ERBE 72072 Tübingen			
A	Datum	Gezeichnet	Geprüft
		27.01.94 M. Friez	20-07-94 H. Hagg
LP un.: 40128-092		LP bs.: 30128-351	
nderung		Blatt 4 von 6	
Nr.	Datum	Name	

ICC 350

Motherboard 30128-351

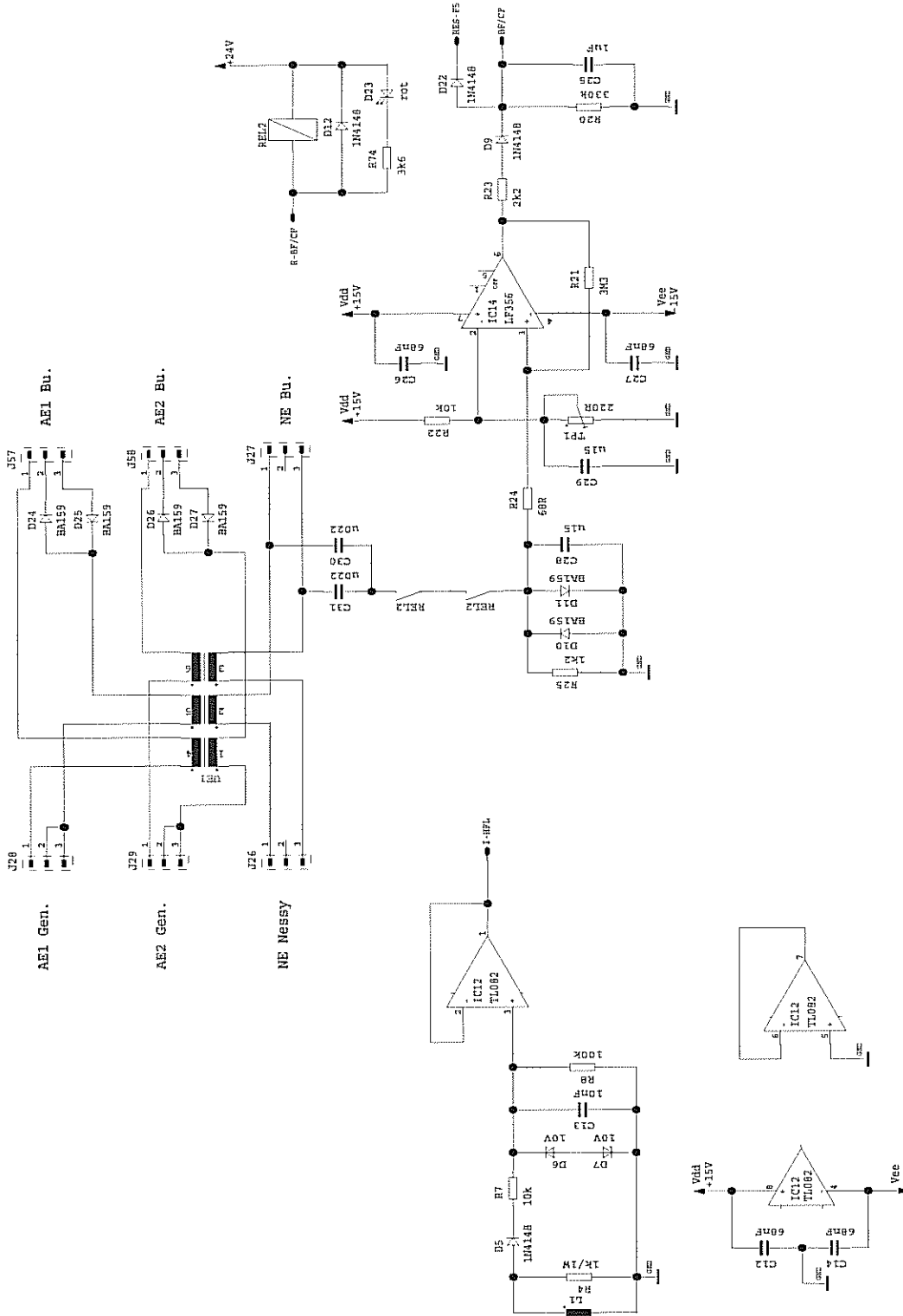

A		Datum		Revis		Gez. Zeichnung		Gez. / DRIT	
		27.01.94		M. Pflitz		Mittelsch. und Vertriebsabtg.		ICC	
		Gez. ft		20.07.94		M. Hagg		Benennung/Title	
		LP un.:		40128-092				Motherboard	
		LP bs.:		30128-351				Zeichnungsnummer/DWG.-NO	
Nr.		nderung		Datum		Name		Blatt 6 von 6	
								72072 TUBINGEN	
								ERBE	

ICC 350

Motherboard (bare) 40128-092

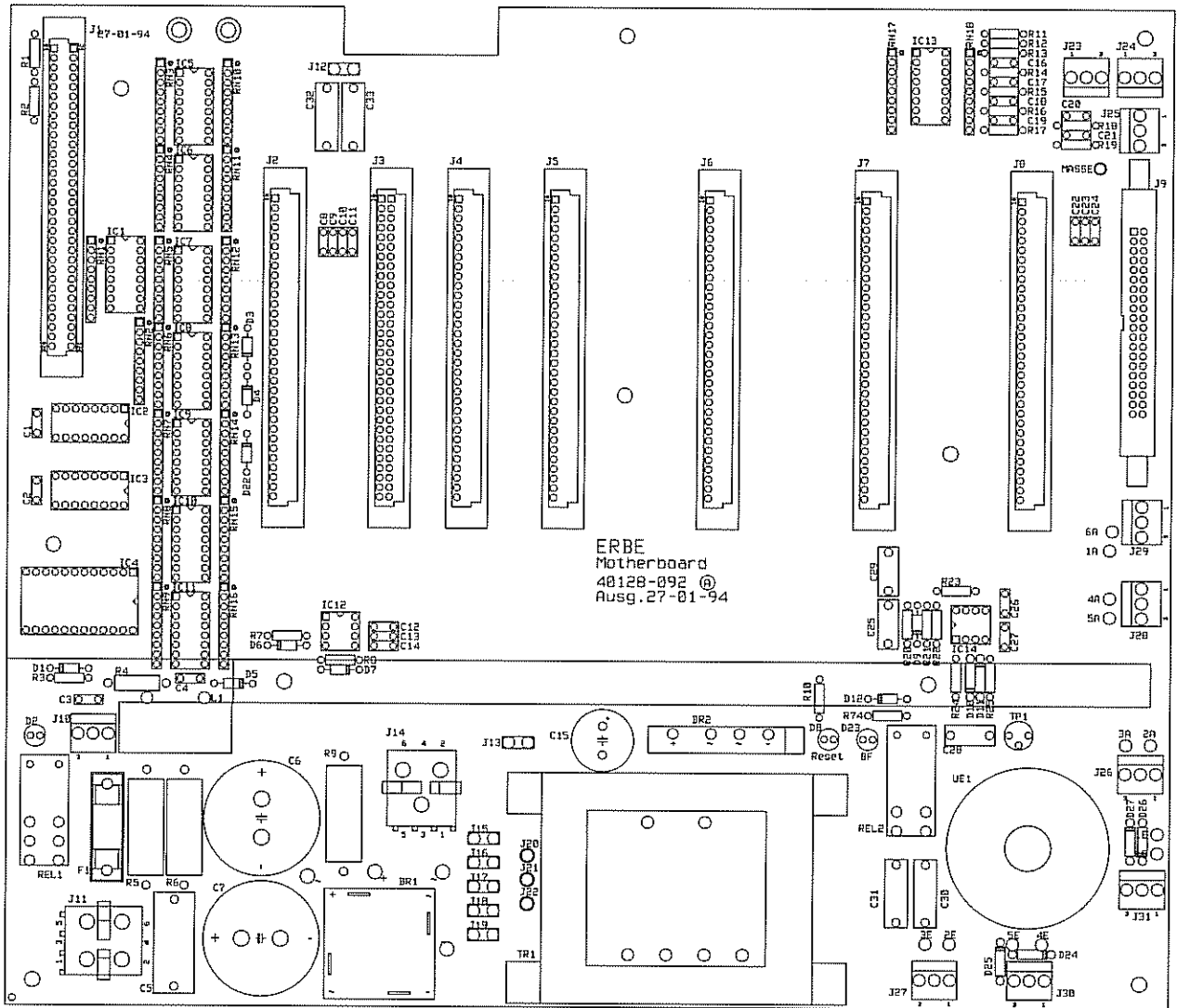

Motherboard
40128-092
27-01-94

Art. No. 80116-201
08 / 2004

ICC 350

Relay Board 30128-352

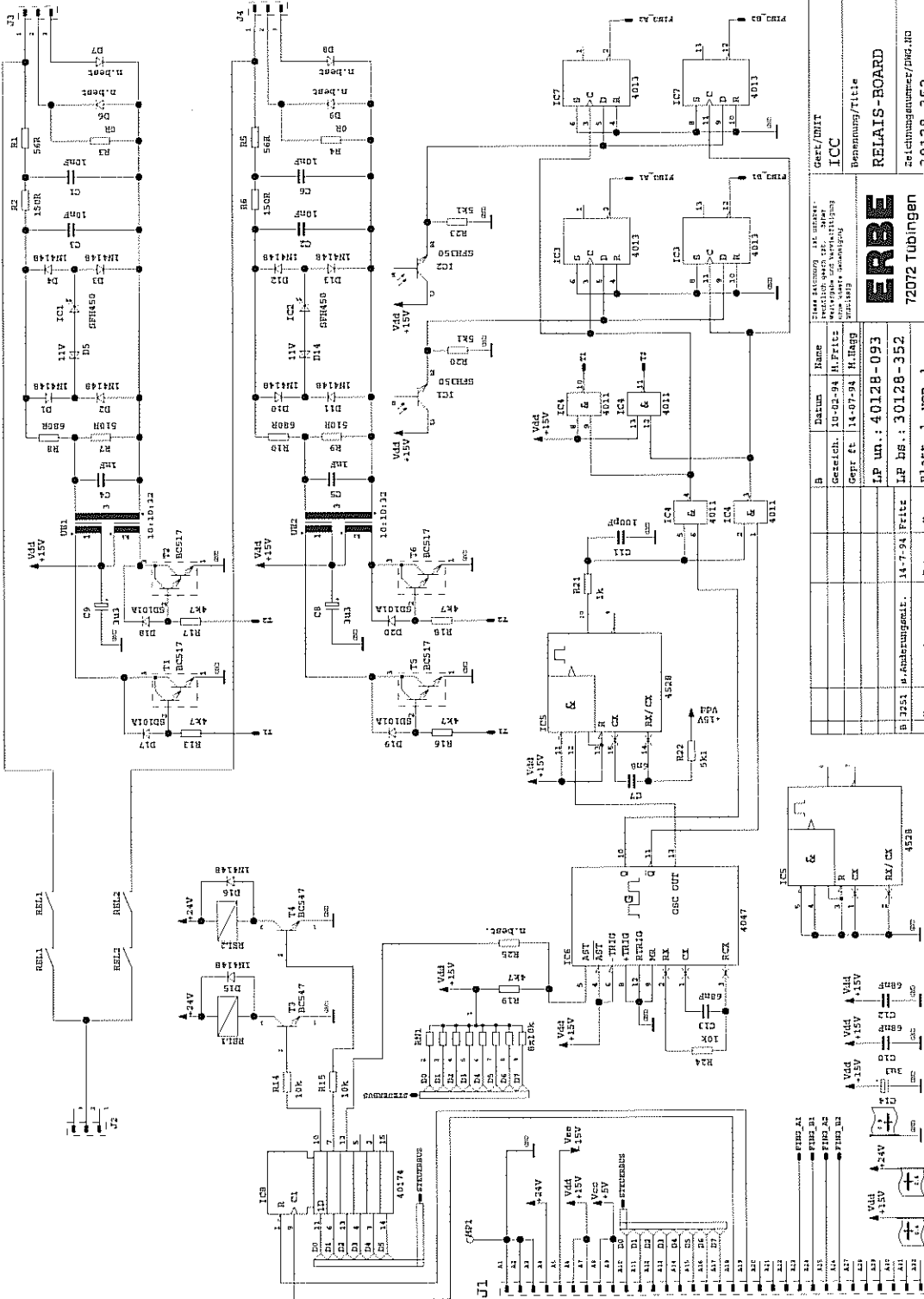

Name		Name	
RELAIS-BOARD		ICC	
72072 Tübingen		ICC	
IP un.: 40128-093		IP un.: 40128-093	
IP bs.: 30128-352		IP bs.: 30128-352	
Blatt 1 von 1		Blatt 1 von 1	

ICC 350

Relay Board (bare) 40128-093

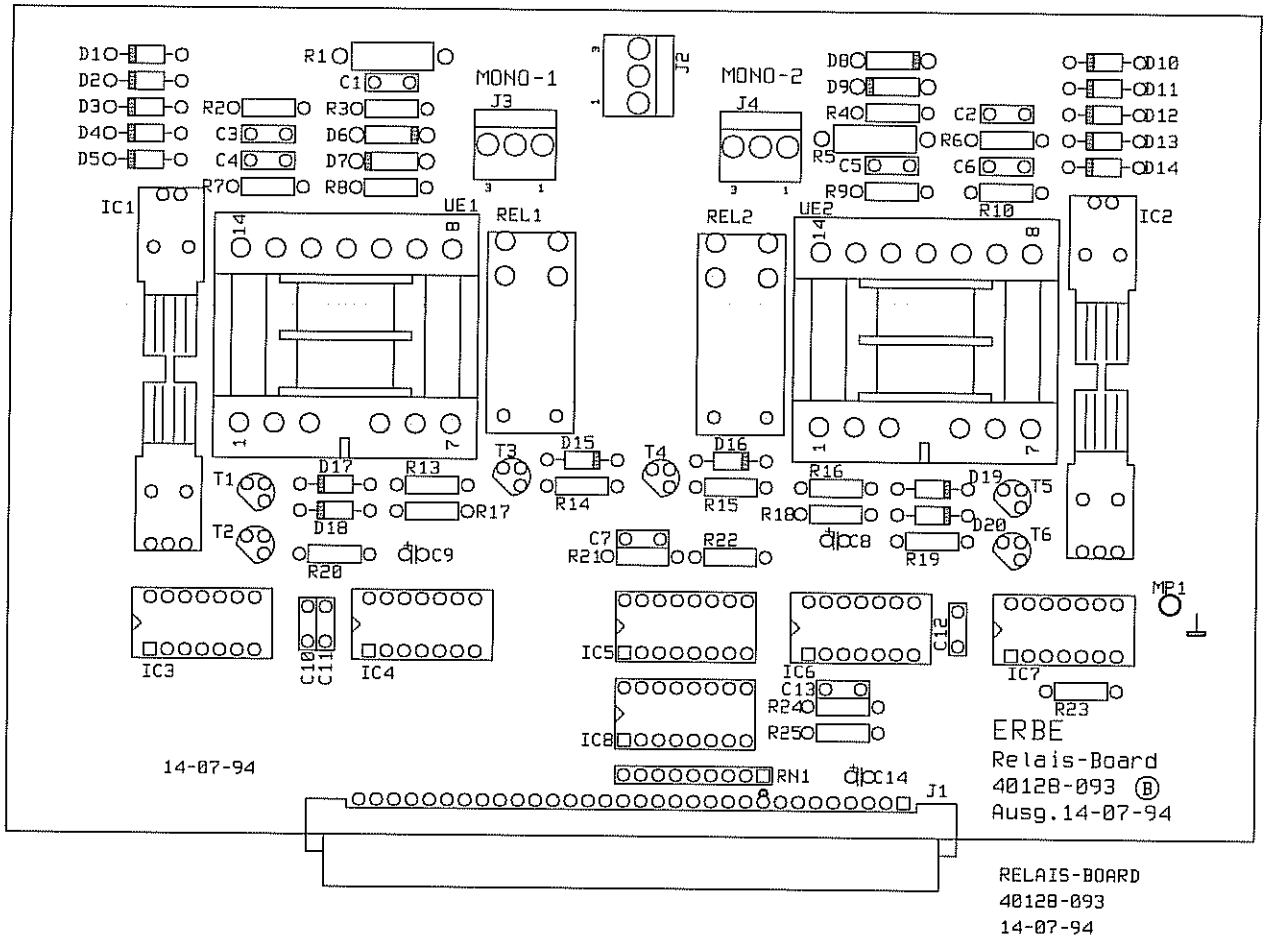

Art. No. 80116-201
09/2004

ICC 350 Neurotest

Neurotest Board 30128-070

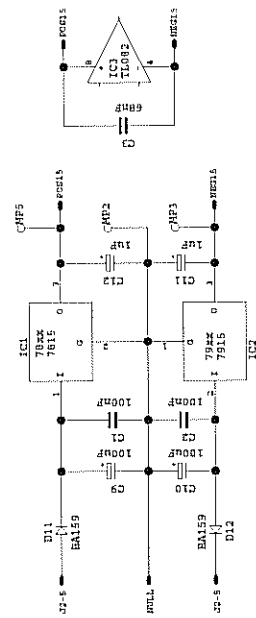
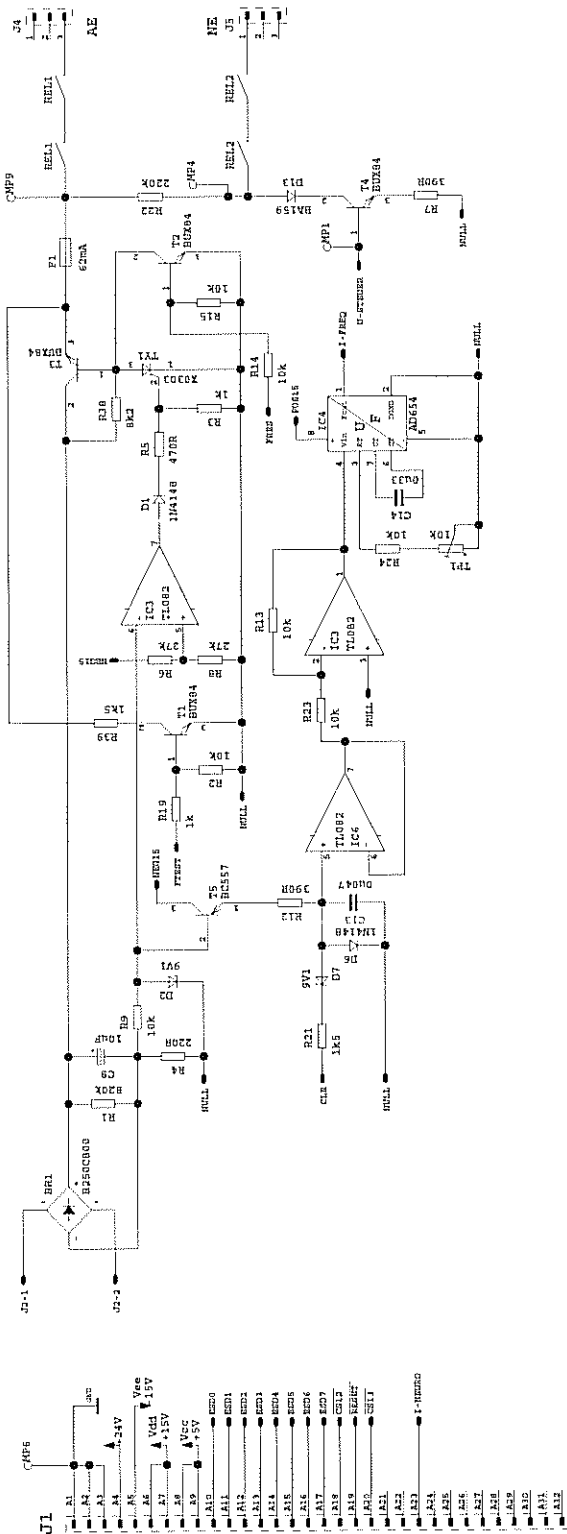

Gerät/DHBT		ICC	
Benennung/Title		Neurotest-Board	
Zeichnungsnummer/DWG.NR.		30128-070	
C		Daten	
Beschreib. M. Fritz		14-06-91	
Gerät		IC	
LP un.:		30128-070	
R36-3kl		14.6.93	
Anordnung		Datei	
Blatt		Blatt 1 von 2	
Nr.		7400 Tübingen	



ICC 350 Neurotest

Neurotest Board 30128-070

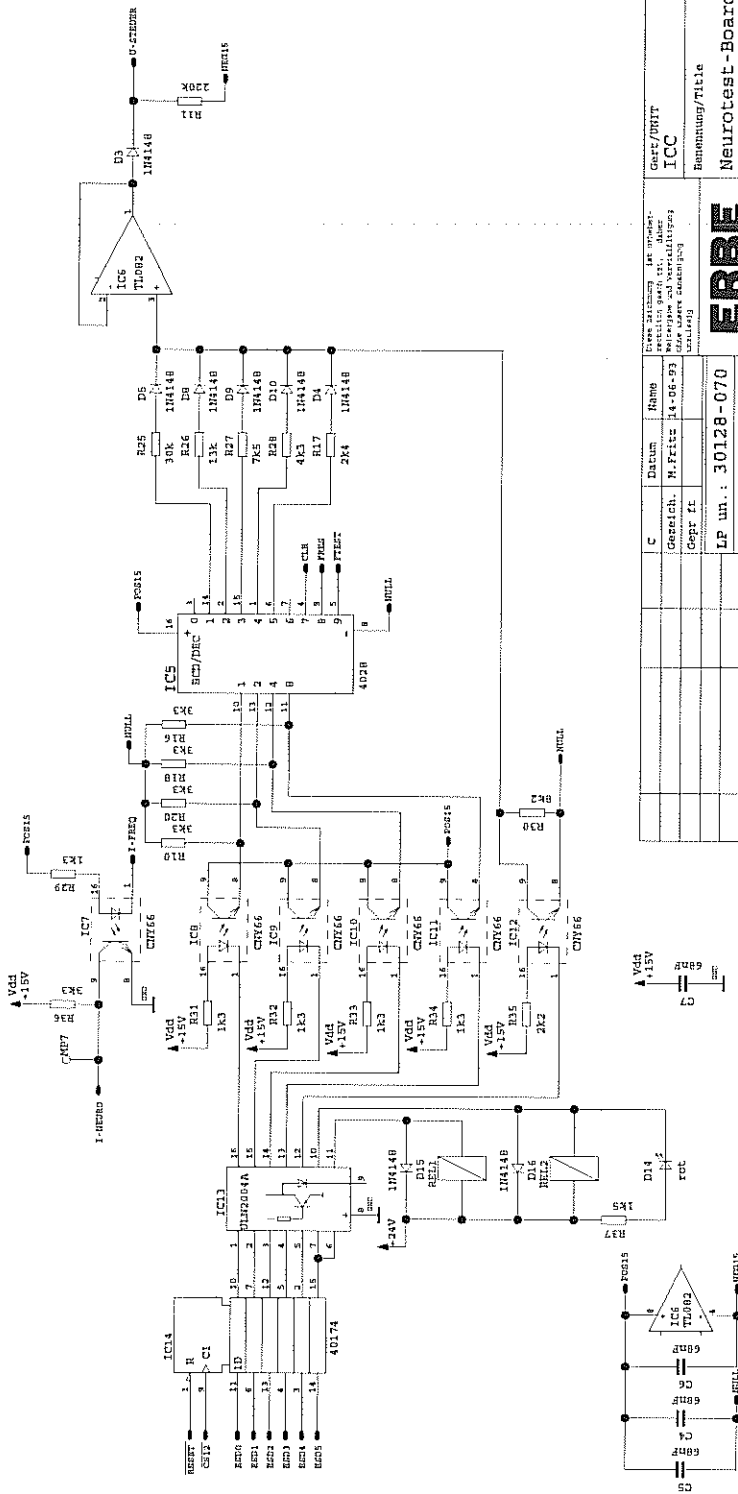

IC1	4013	Flip-Flop
IC2	4028	Microcontroller
IC3	4028	Microcontroller
IC4	4028	Microcontroller
IC5	4028	Microcontroller
IC6	TL092	Operational Amplifier
IC7	40174	Decoder

Gezeichnet	M. Fritz	14.06.93
Geprüft		
LP un.	30128-070	
LP Ba.	40128-027	
Blatt	2 von 2	

Artz/PRIT	ICC
Benennung/Title	Neurotest-Board
Zusatznummer/Dwg. No.	30128-070



Art. No. 80116-201
08/2004

ICC 350 Neurotest

Neurotest Board 40128-027

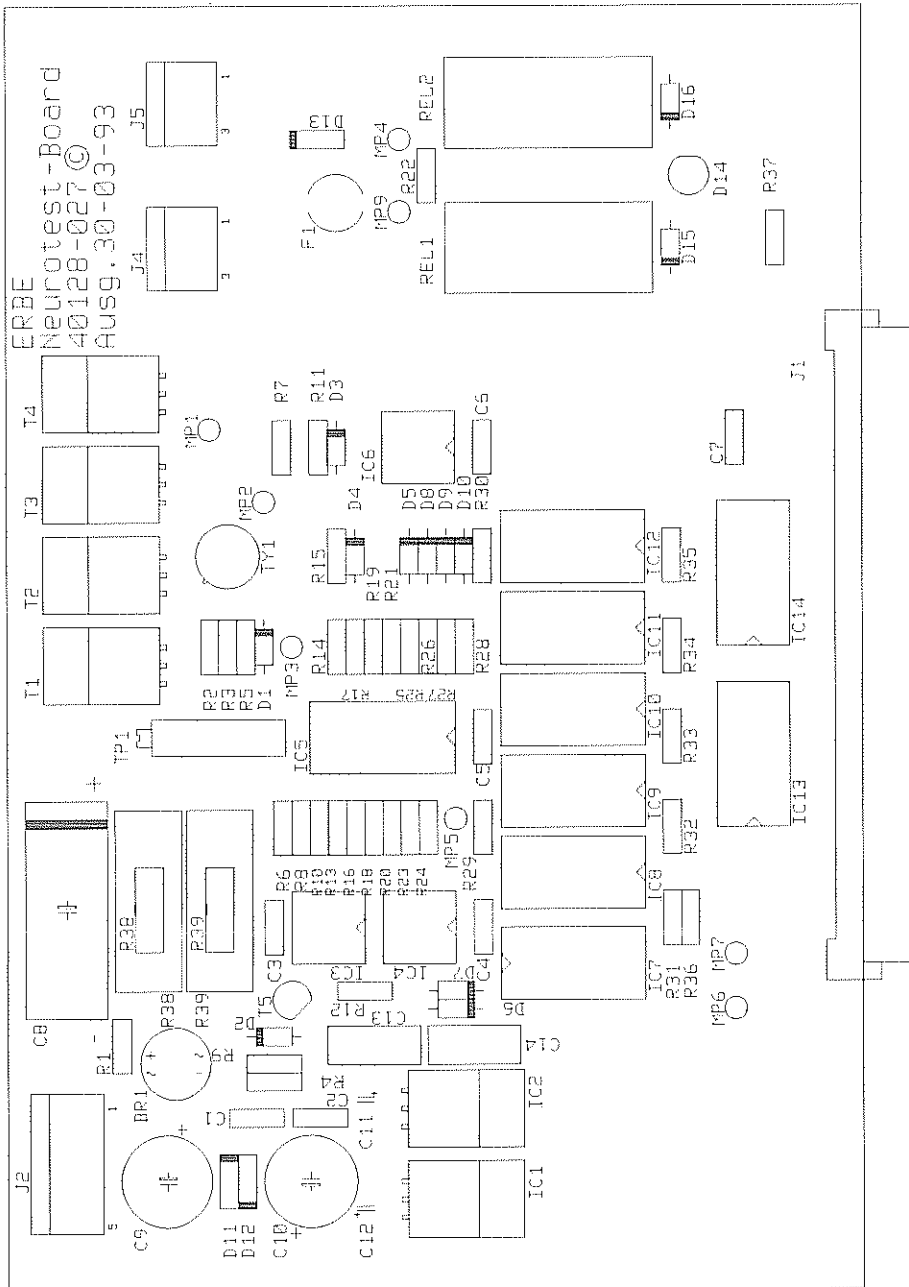

Neurotest-Board
40128-027
30-03-93

ICC 350 Neurotest

Motherboard Neurotest 30128-071

Art. No. 80118-201
09/2004

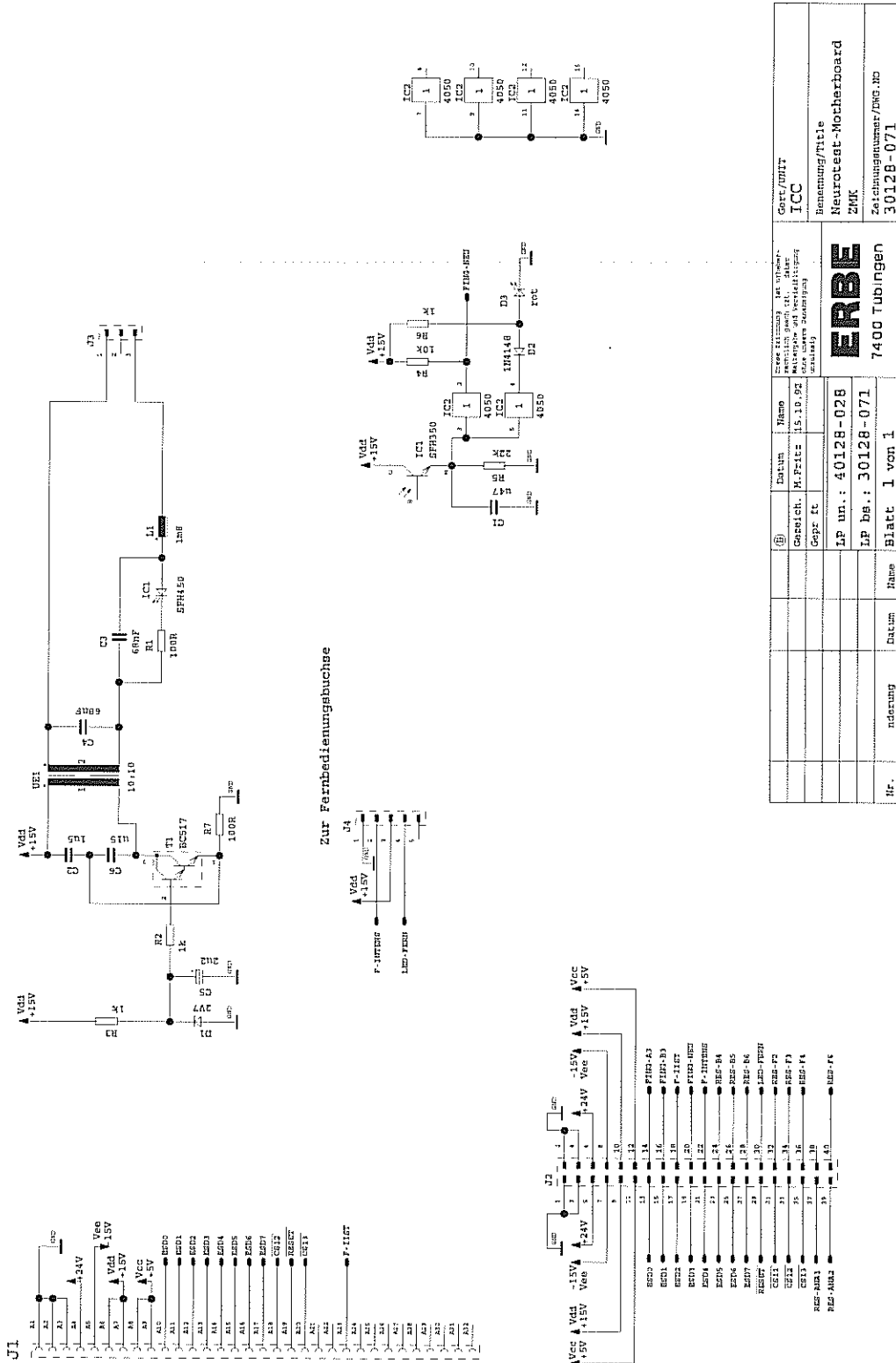

Geräte/IC/IT	ICC
Bezeichnung/Title	Neurotest-Motherboard
ZMK	
Zeichnungsnummer/DWG. No.	30128-071
Datum	15.10.92
Gezeichnet	M. Pfitz
Geprüft	
IP un.	40128-028
IP Ba.	30128-071
Blatt	1 von 1
Hersteller	ERBE
Werk	7400 Tübingen

ICC 350 Neurotest

Motherboard Neurotest (bare) 40128-028

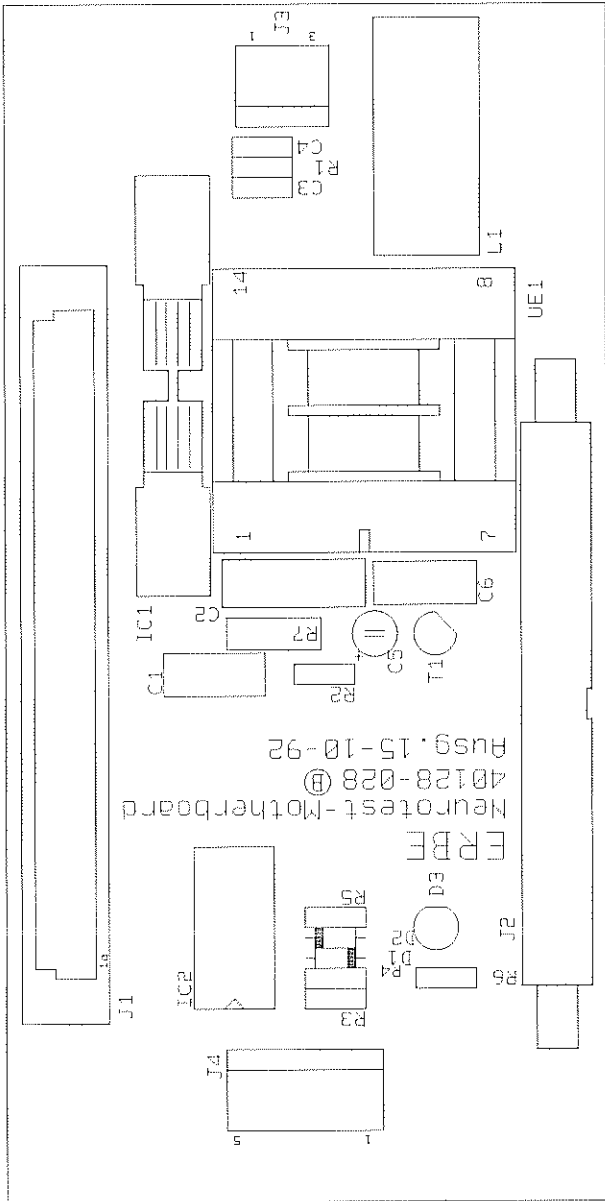

Neurotest-Motherboard
40128-028
15-10-92

ICC 350 MIC-MEN-DOKU

MIC Board 30128-200

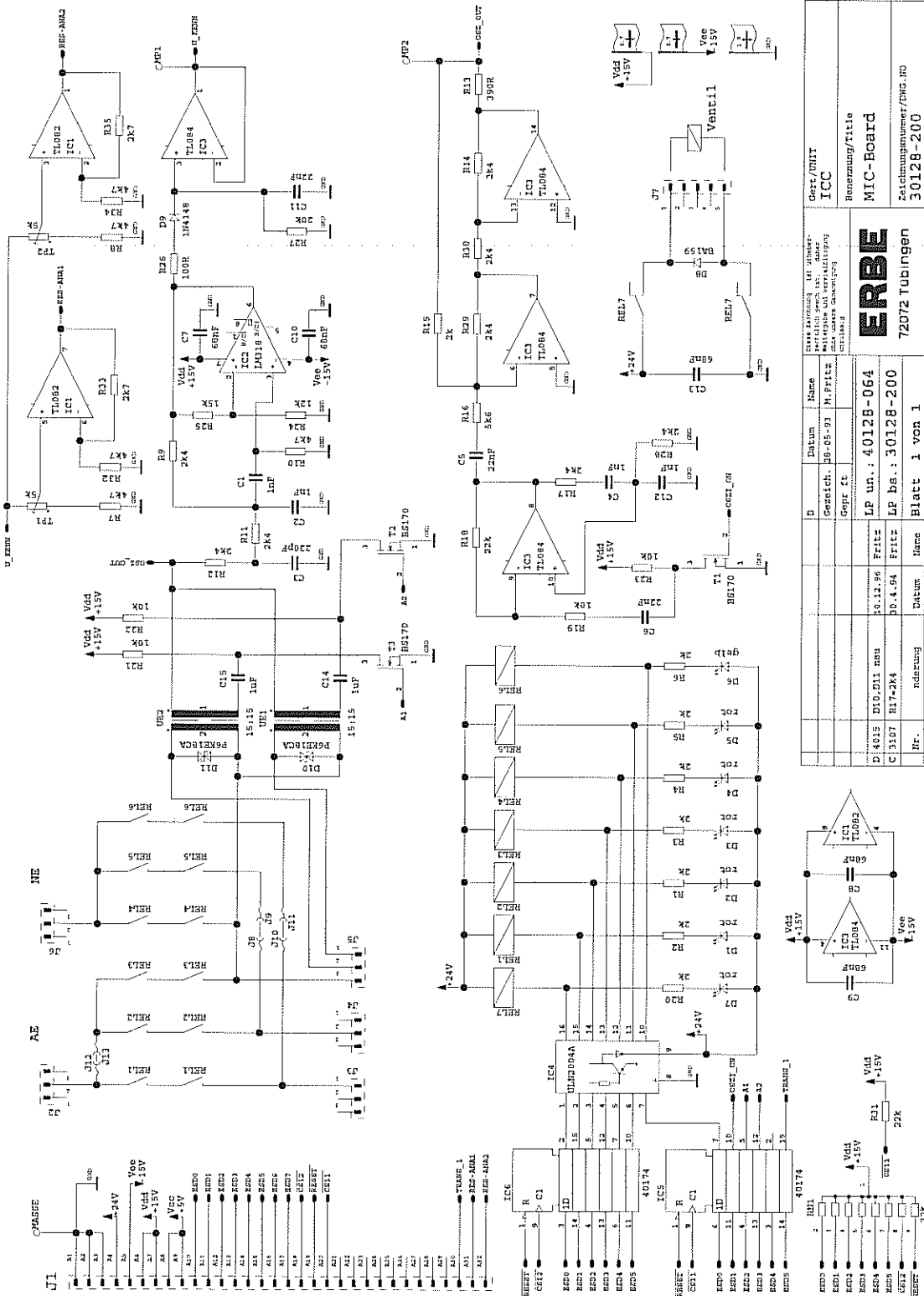

D	Name	Gez.	Datum	Rev.
D 4015	D10-D11 manu	Fritz	30.12.96	
C 3107	R17-R24	Fritz	30.4.94	
Name: ERBE 72072 Tübingen Blatt 1 von 1				

Gerz./BRIT		Benennung/Title	
ICC		MIC-Board	
Zustellungsnummer/DWG.-Nr.		30128-200	

Art. No. 80116-201
09/2004

ICC 350 MIC-MIEN-DOKU

MIC Board (bare) 40128-064

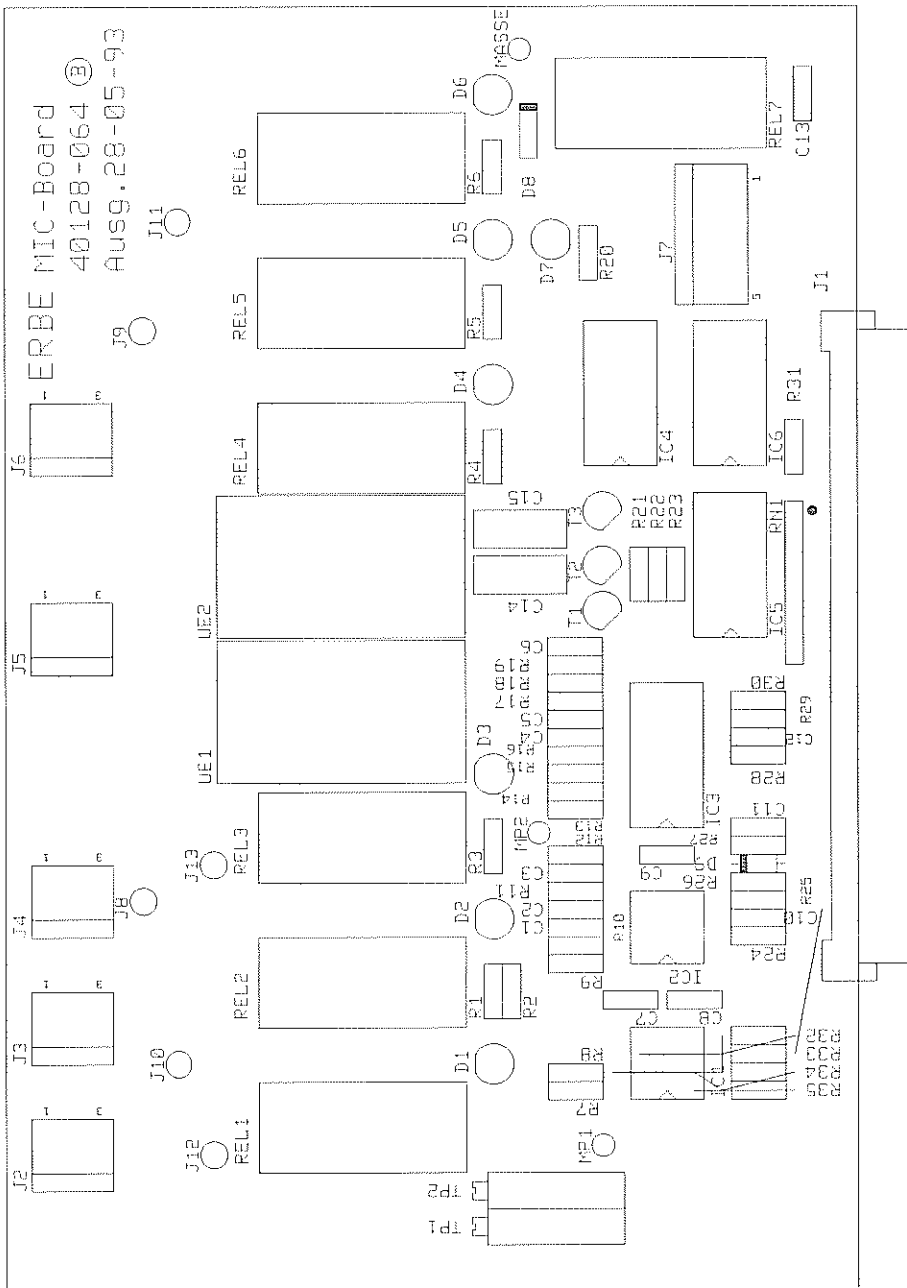

MIC-Board
40128-064
28-05-93

ICC 350 MIC-MIEN-DOKU

Protection Board (bare)

40128-141

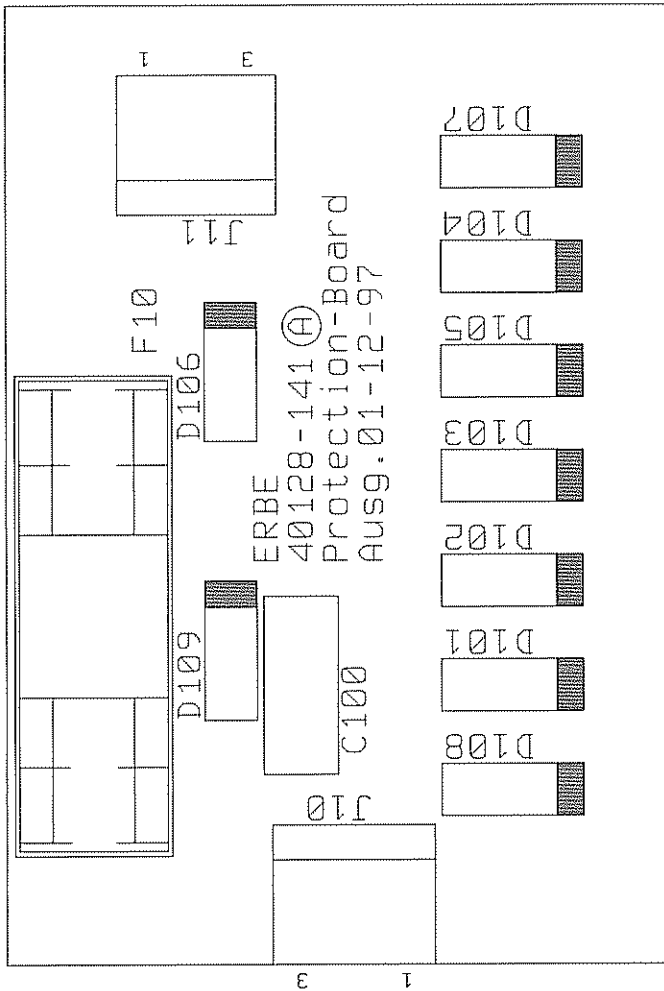

Appendix A

Part Numbers

ICC 200 (D)

10128-002/-010/-023

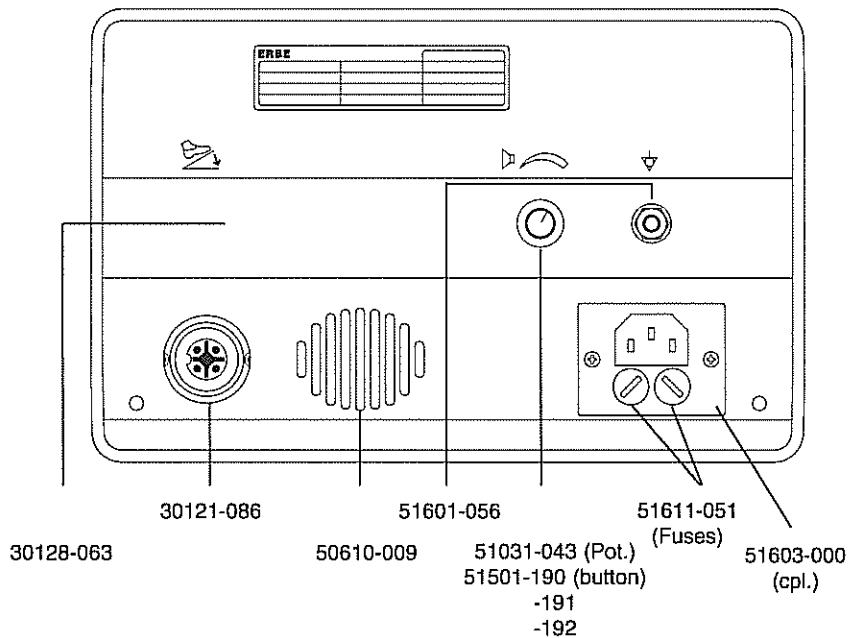
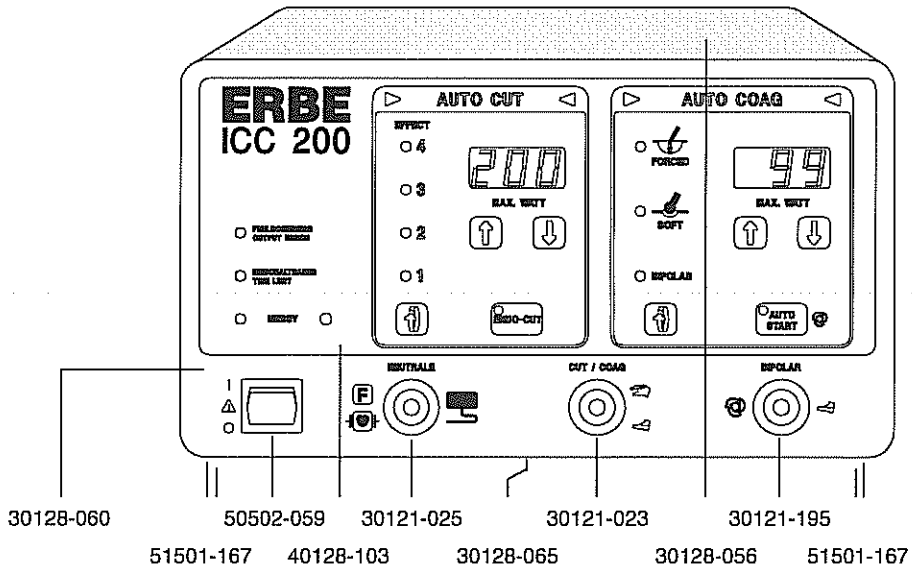

Art.-No. 80116-201
09/2004

ICC 200 (UL)

10128-202/-204/-205

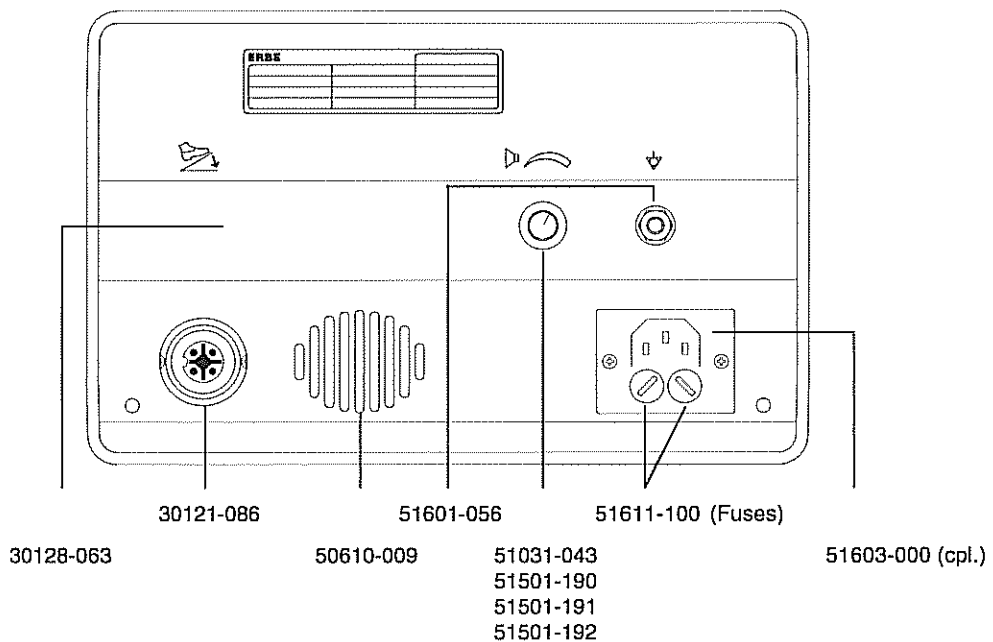
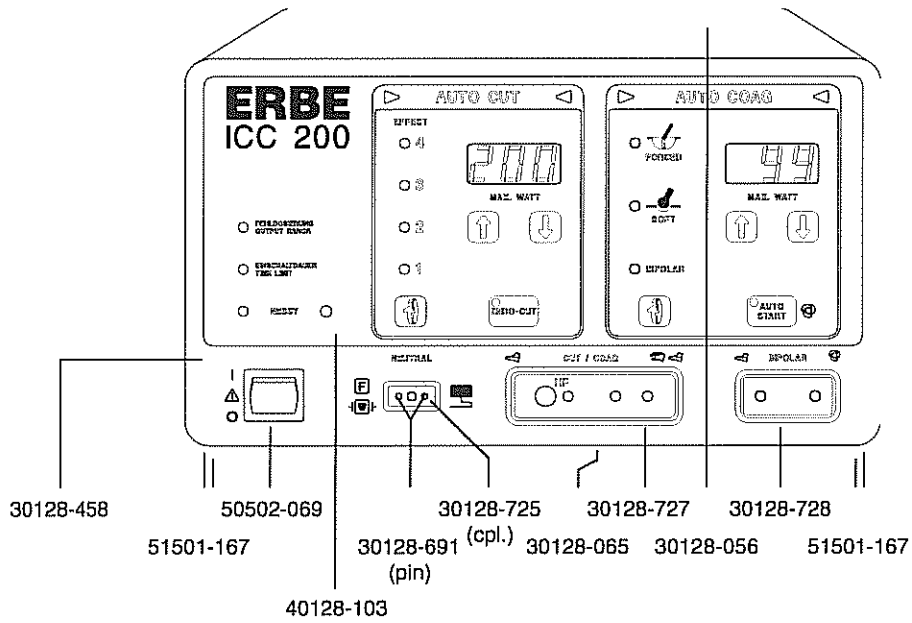

ICC 200 (INT)

10128-009/-015/-036

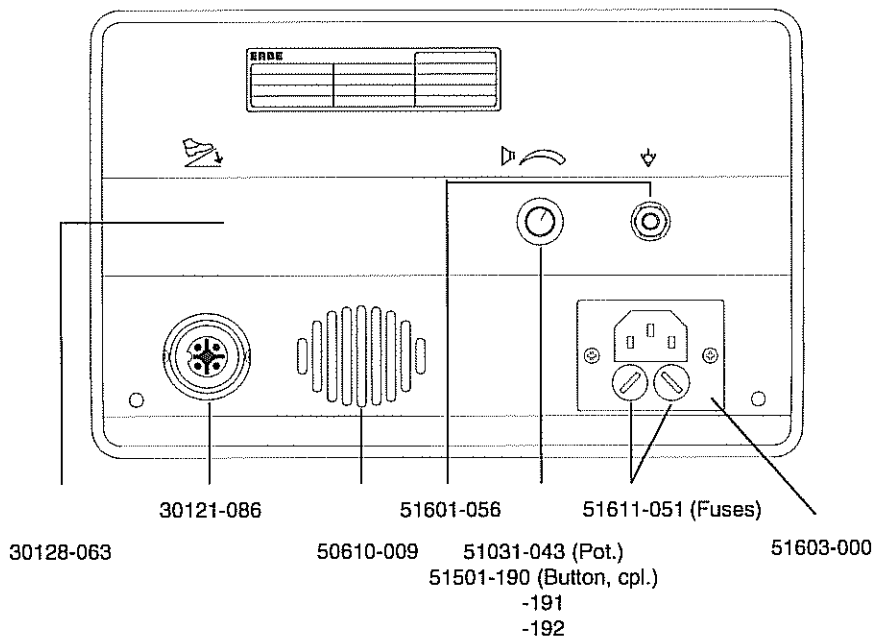
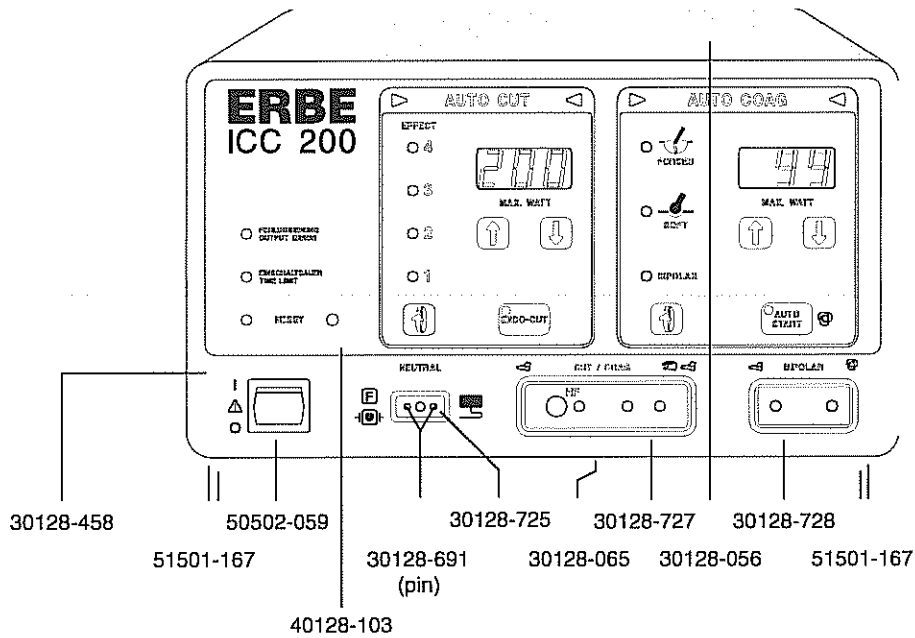

Art.-No. 80116-201
09/2004

ICC 200 (F)

10128-051/-054/-056

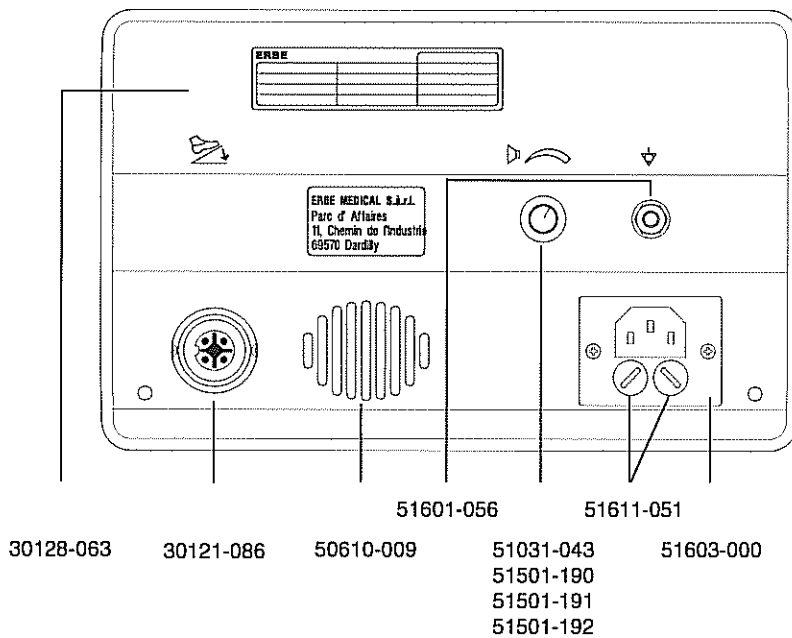
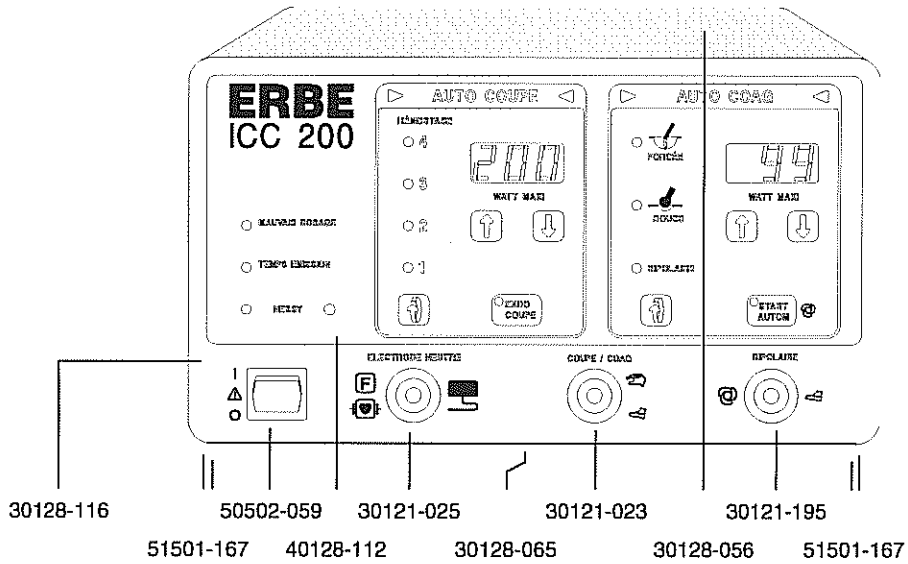

ICC 200

Boards

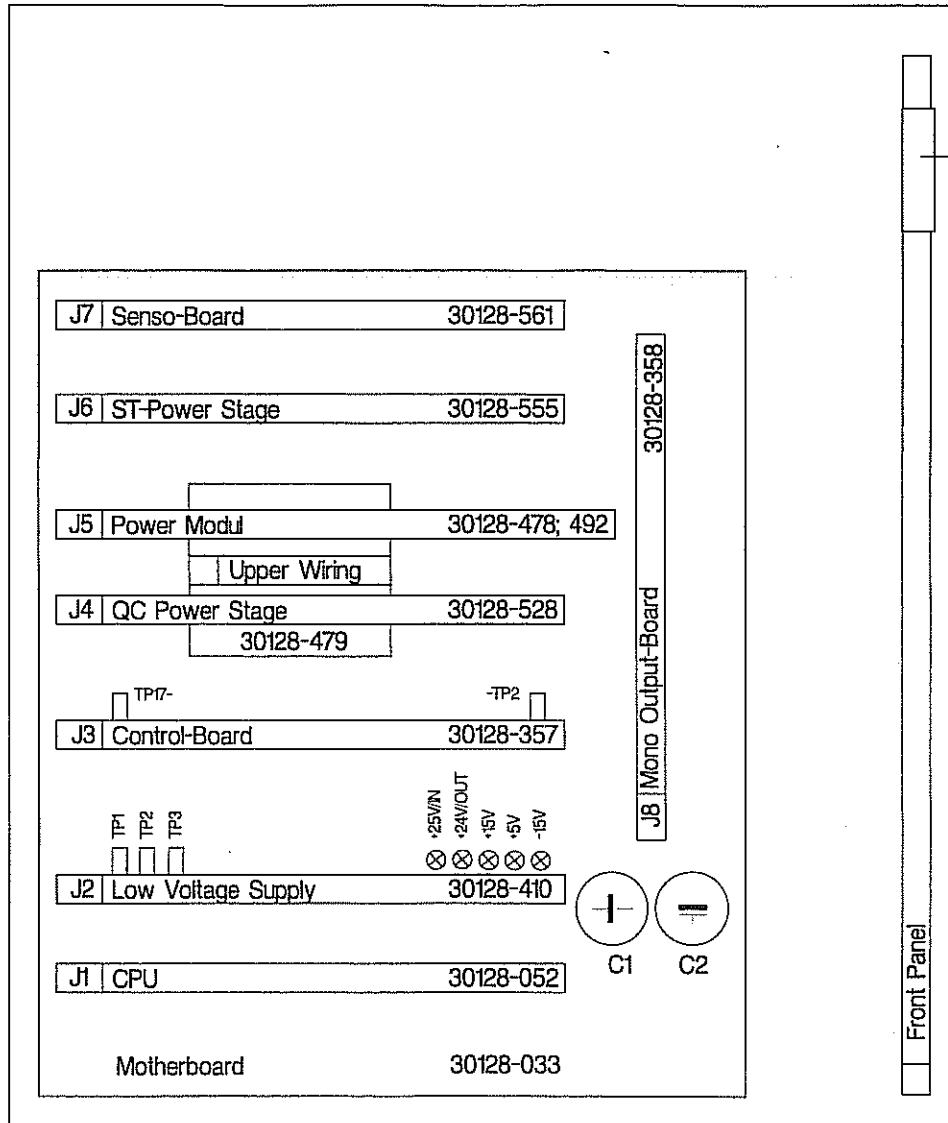

40128-103
40128-112 (F)

Gezeich. = Drawn

Geprüft = Checked

Freigabe = Approv.

Datum = Date*

Name = Name

Maßstab = Scale

Datei = File

Projekt = Project

Benennung = Title

Nummer = Number

Ers. für = Replaces

Ers. durch = Repl. by

Art.-No. 80116-201
09/2004

	Datum	Name	Maßstab	Datei	PCB.ged
Gezeich.	05.97	Karlsberg	Projekt	V 2.0	
Geprüft			Benennung	ICC 200	
Freigabe			Nummer	PCB	
ERBE 72072 Tübingen			Ers. für:	Ers. durch:	

ICC 300 (D)

10128-070, -071

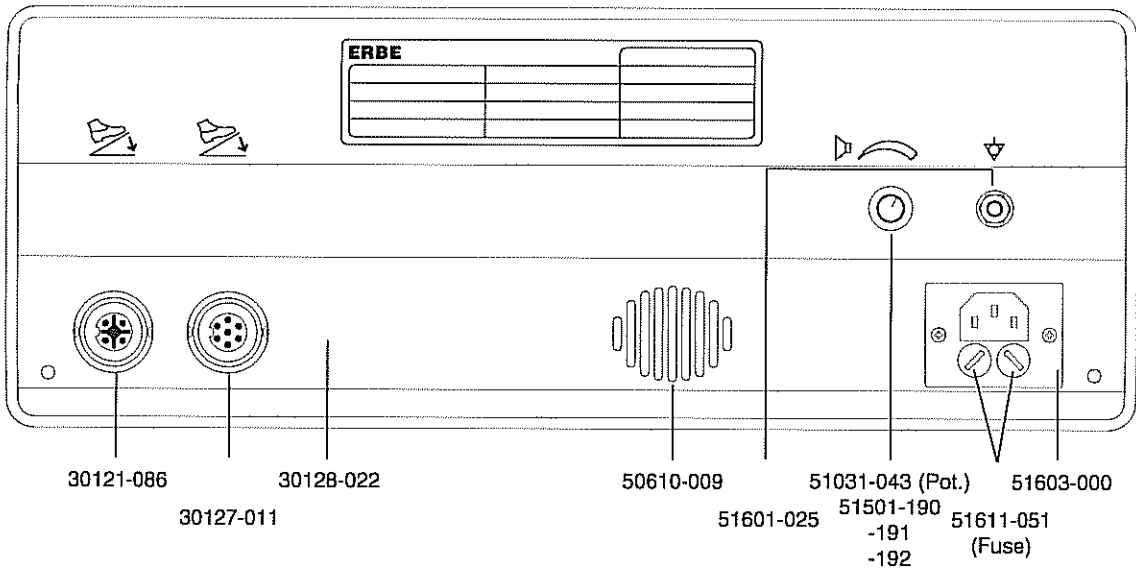
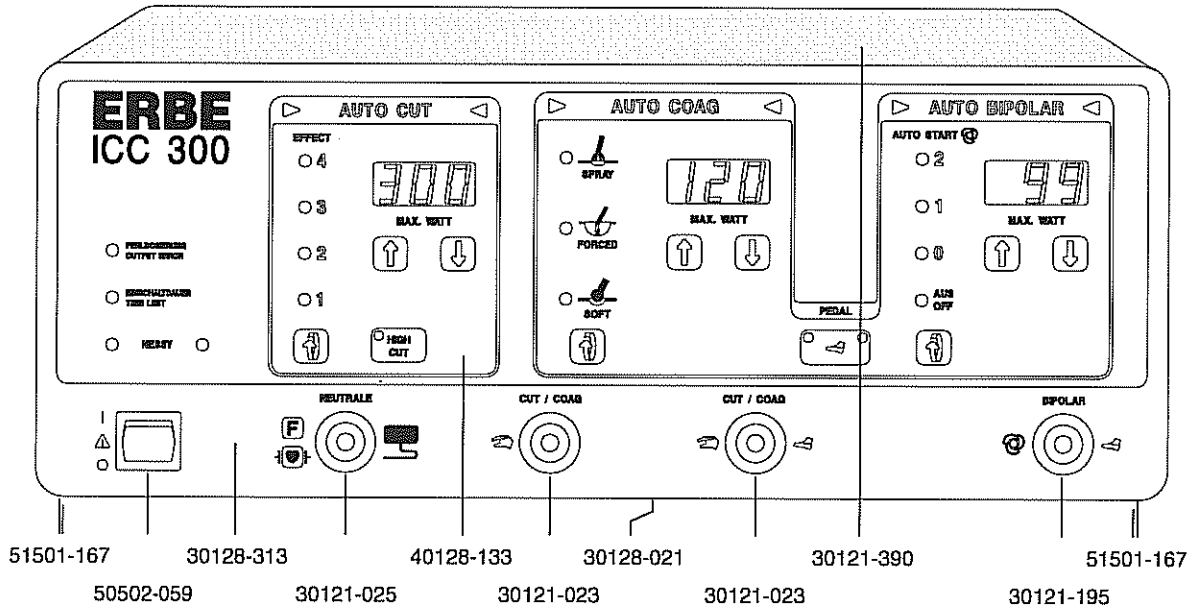

ICC 300 (UL)

10128-213, -214

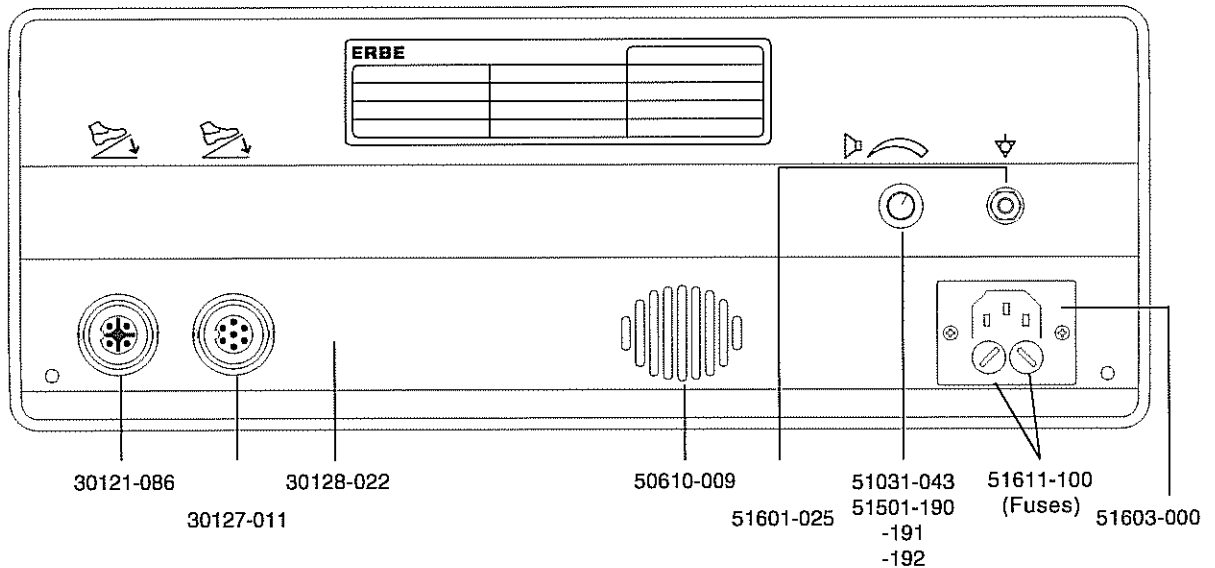
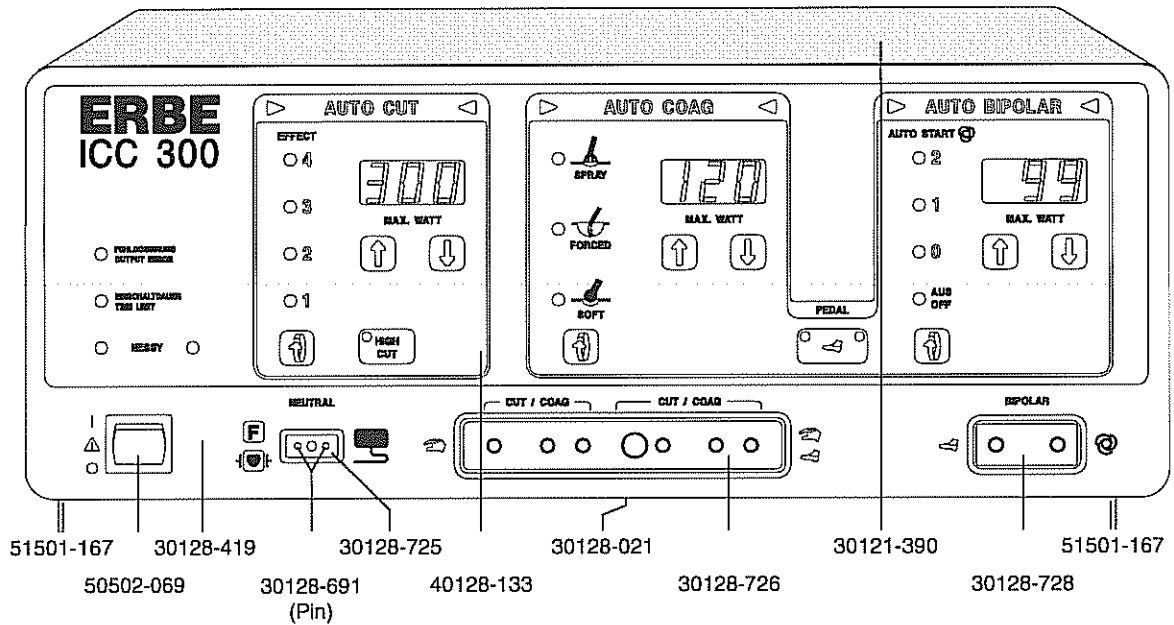

Art.-No. 80116-201
09/2004

ICC 300 (INT)

10128-077, -078

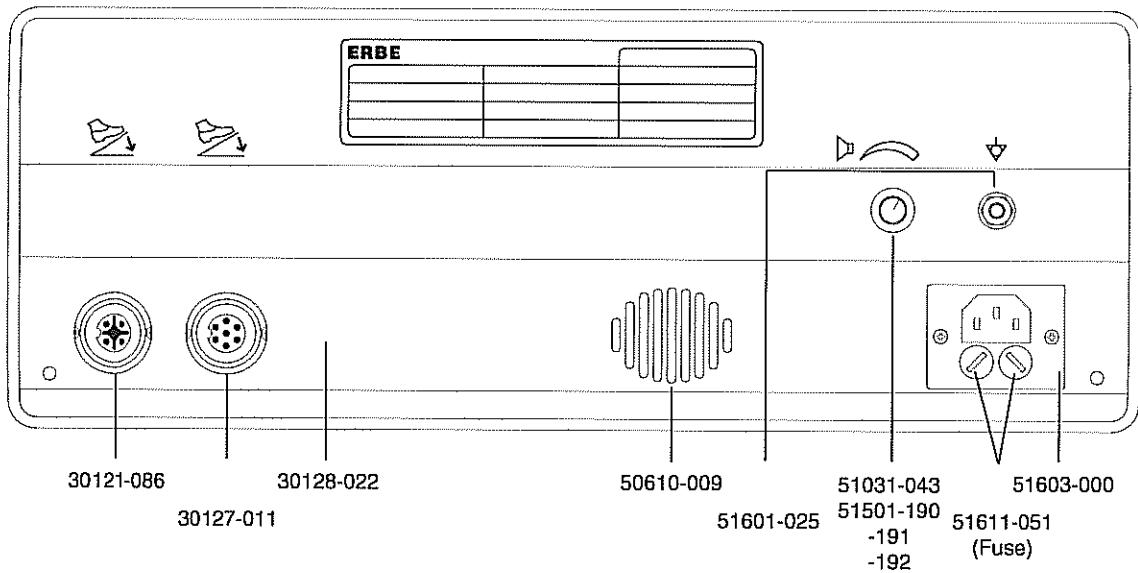
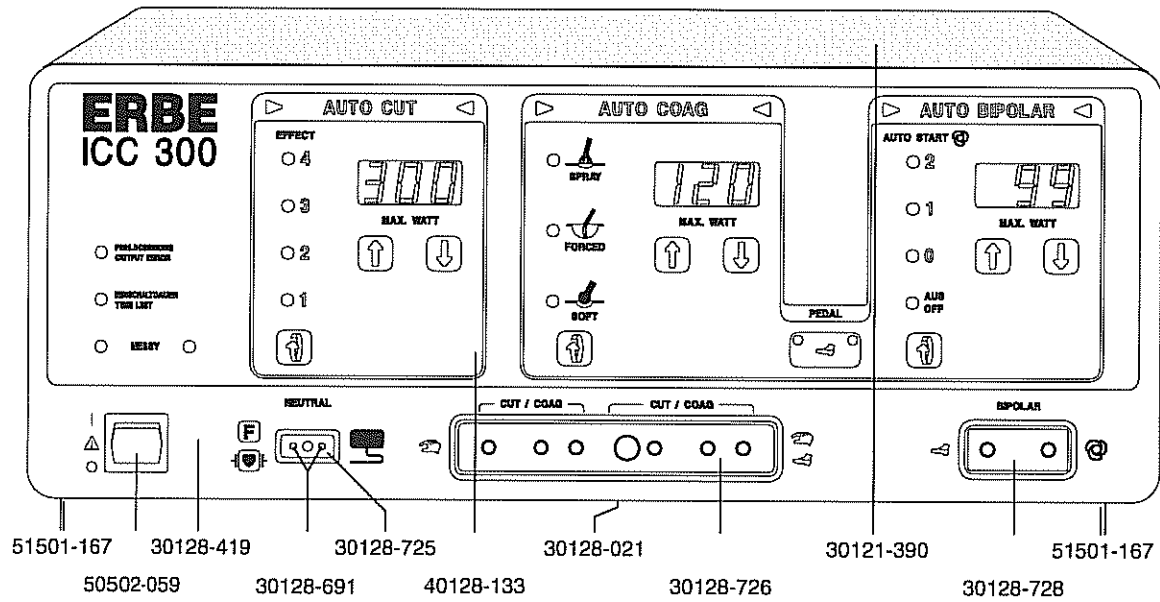

ICC 300 (F)

10128-072, -073

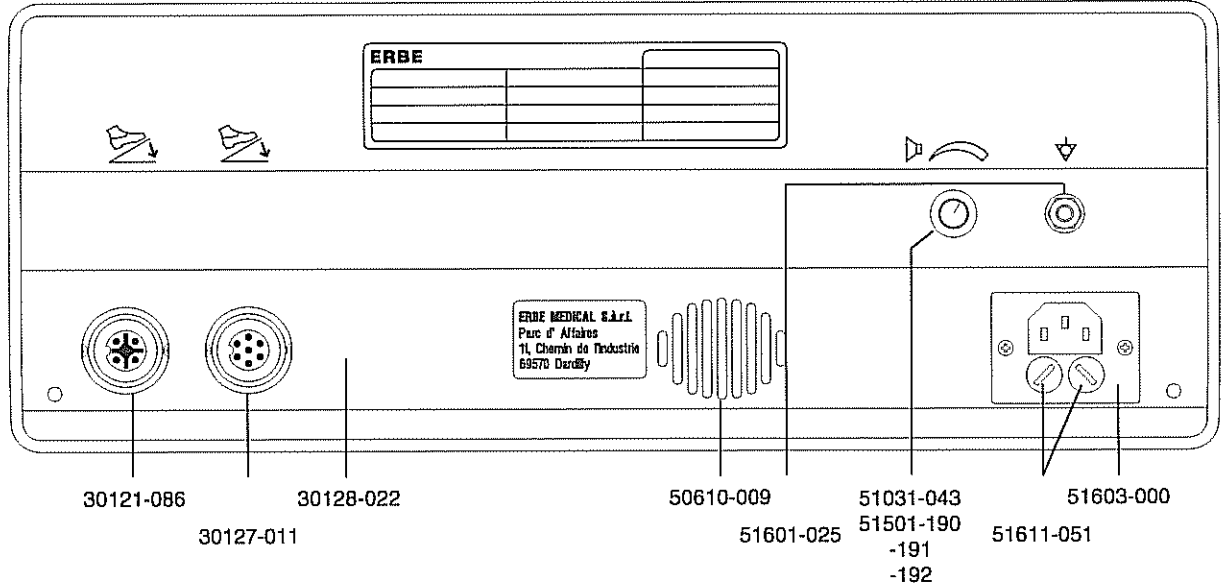
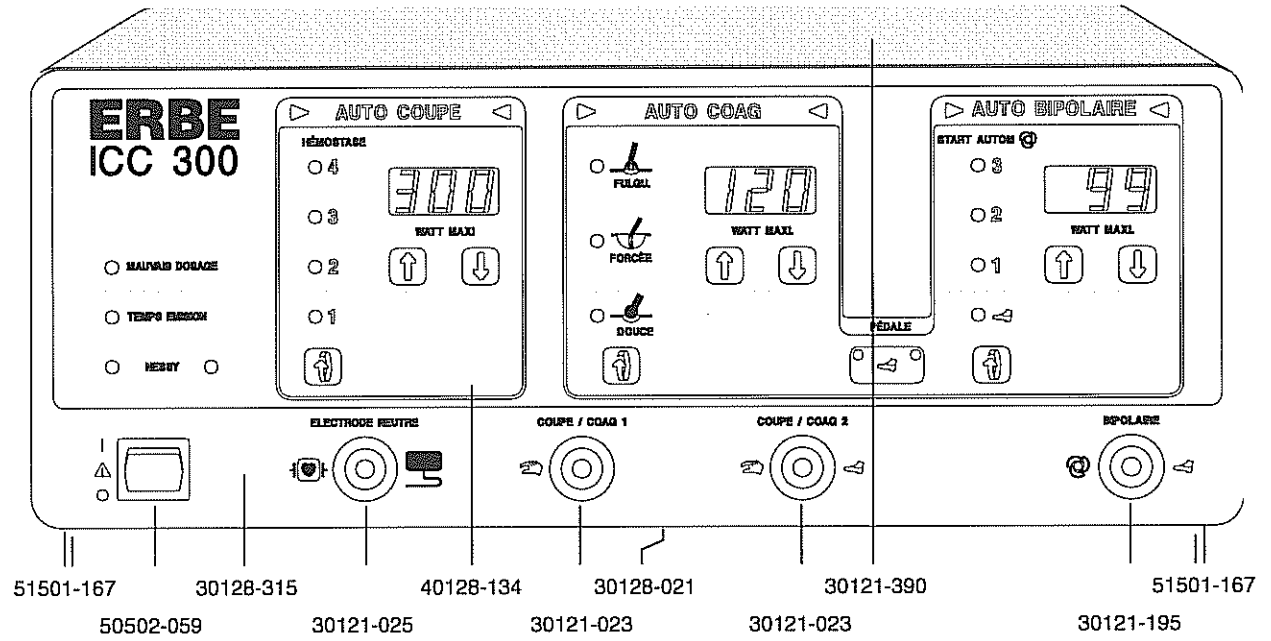

0411 - No. 80116-201
09/2004

ICC 300

Boards

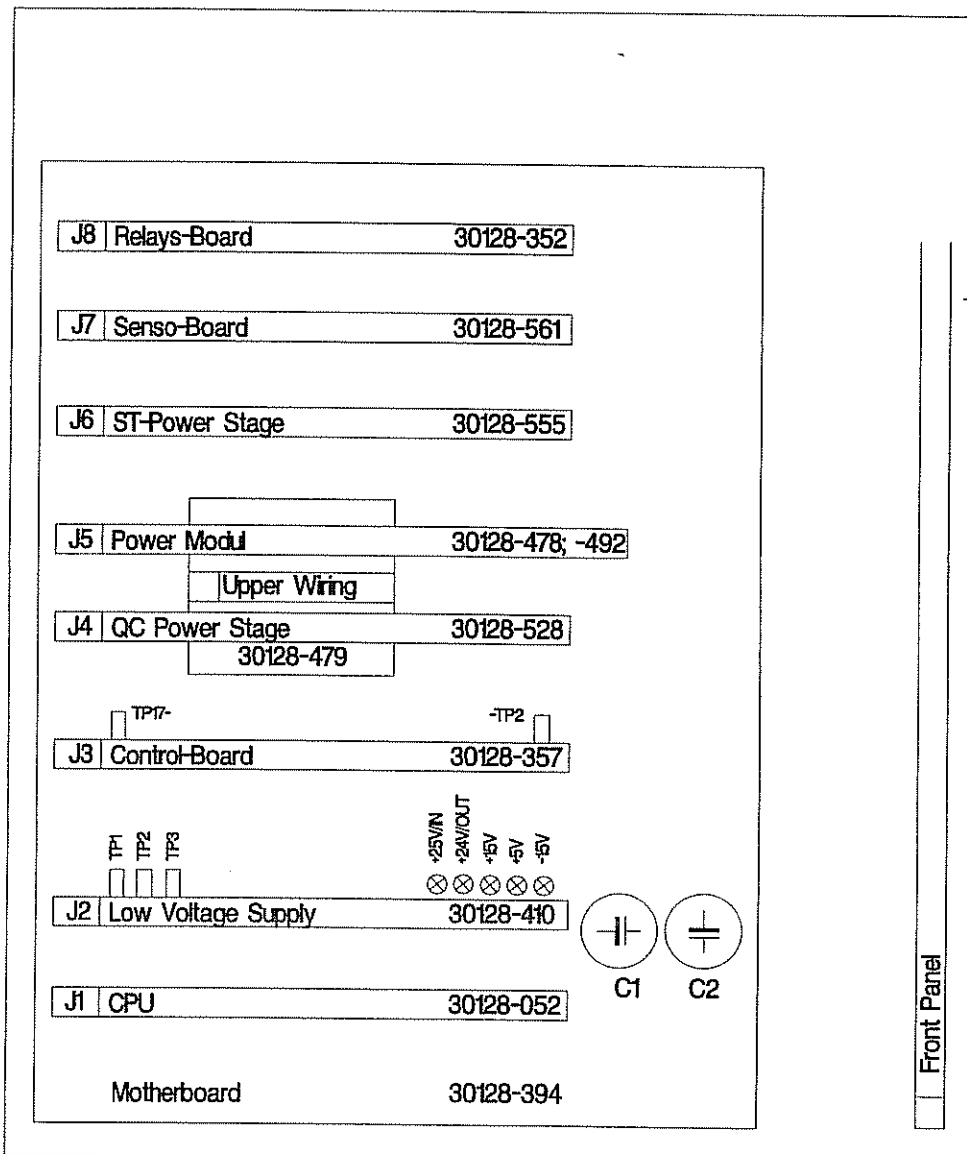

40128-133 (D/INT)
40128-134 (F)

- Gezeichnet = Drawn
- Geprüft = Checked
- Freigabe = Approv.
- Datum = Date*
- Name = Name
- Maßstab = Scale
- Datei = File
- Projekt = Project
- Benennung = Title
- Nummer = Number
- Ers. für = Replaces
- Ers. durch = Repl. by

	Datum	Name	Maßstab	Datei	PCBd.ged
Gezeichnet	04.97	Kartsberg	Projekt	V 2.0	
Geprüft					
Freigabe			Benennung		
ERBE 72072 Tübingen			ICC 300		
			Nummer		
Ers. für.:			Ers. durch:		

ICC 350 (D)

10128-016 (Endo)

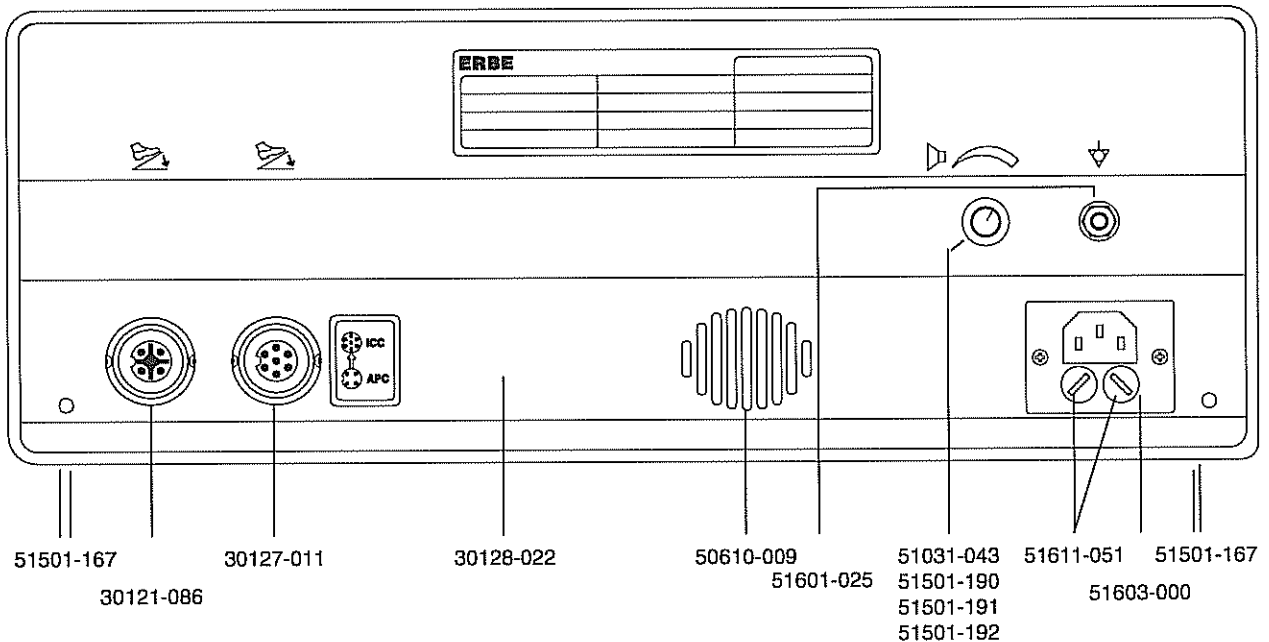
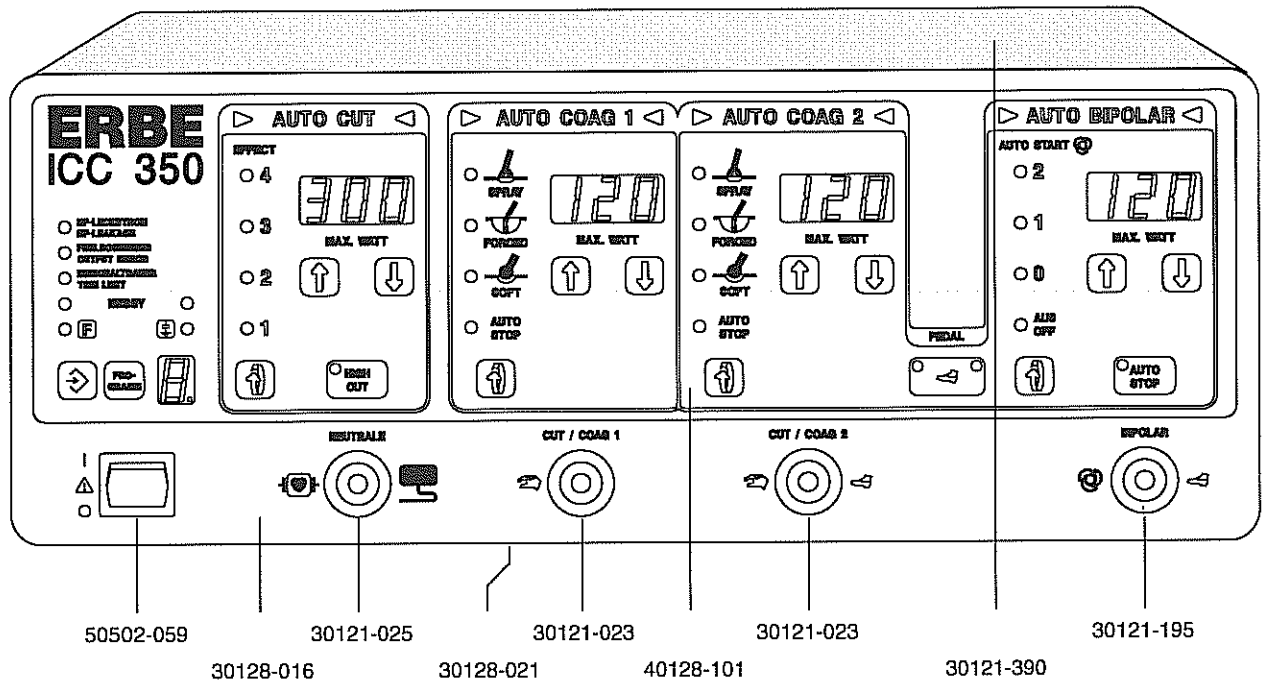

Art.-No. 80116-201
09/2004

ICC 350 (UL)

10128-200, -206 (Endo)

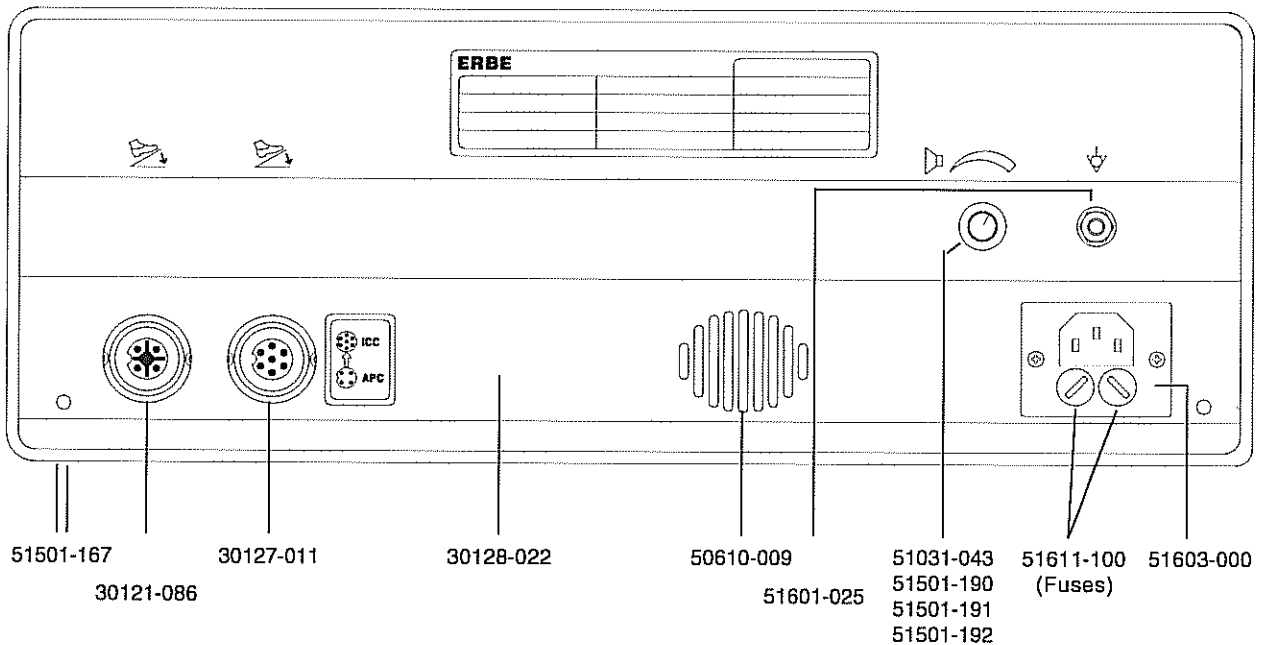
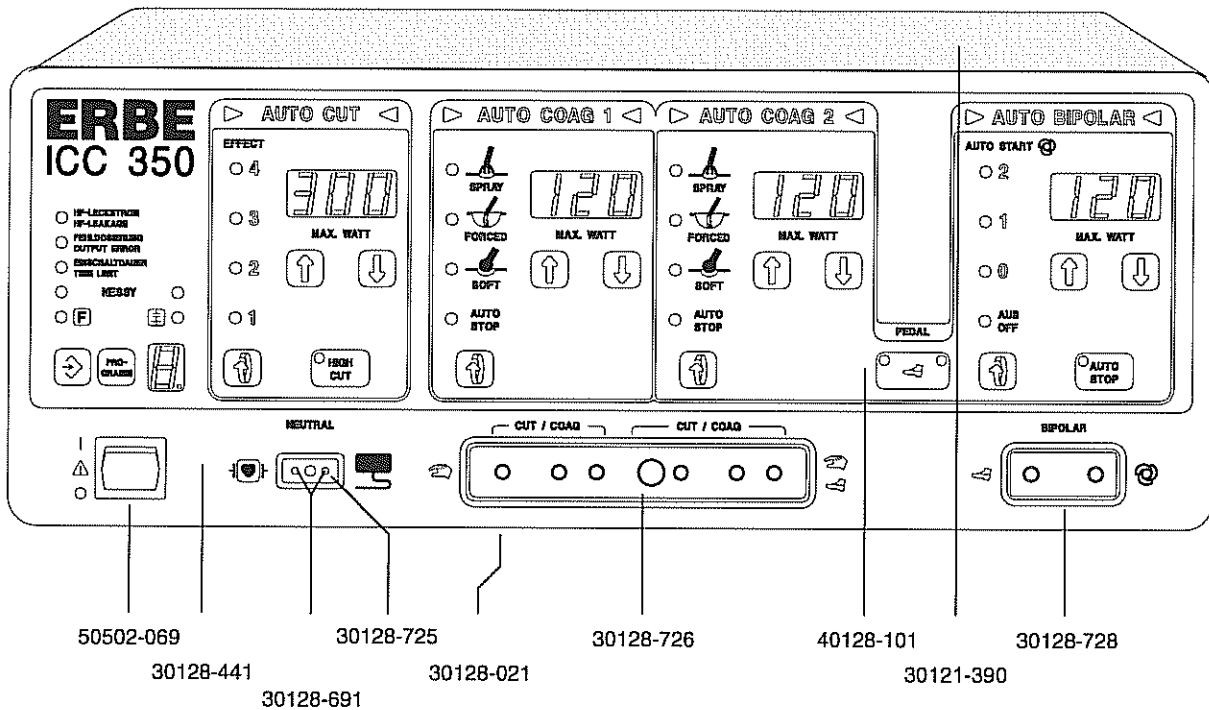

ICC 350 (INT)

10128-061 (Endo)

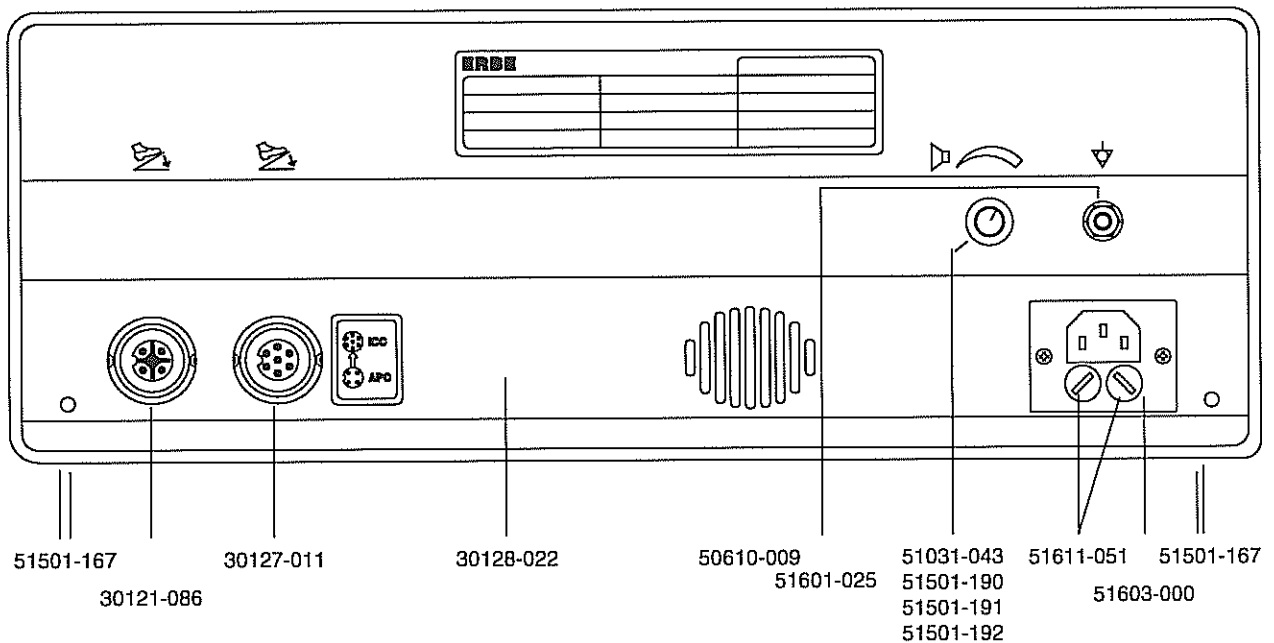
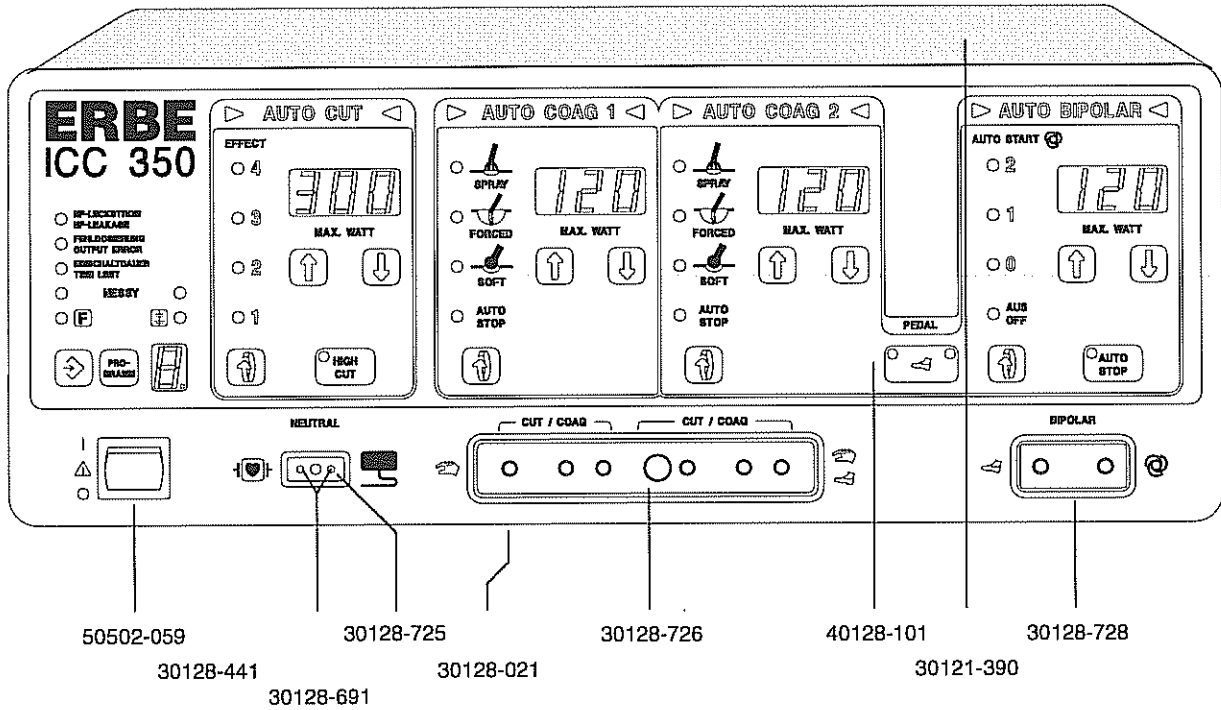

Art.-No. 80116-201
09/2004

ICC 350 (F)

10128-055 (Endo), -082 (MIC)

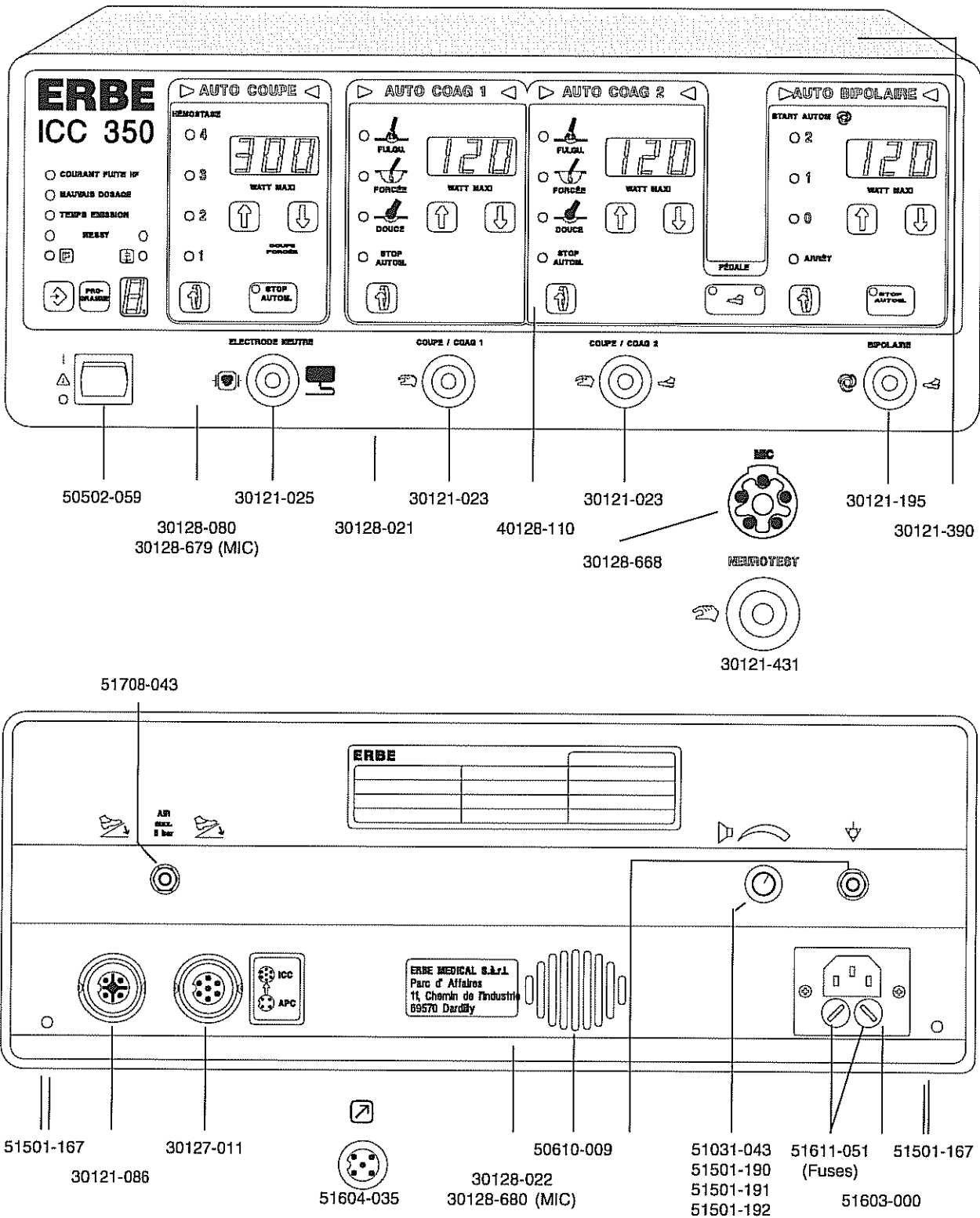

ICC 350 M-Doku

10128-081

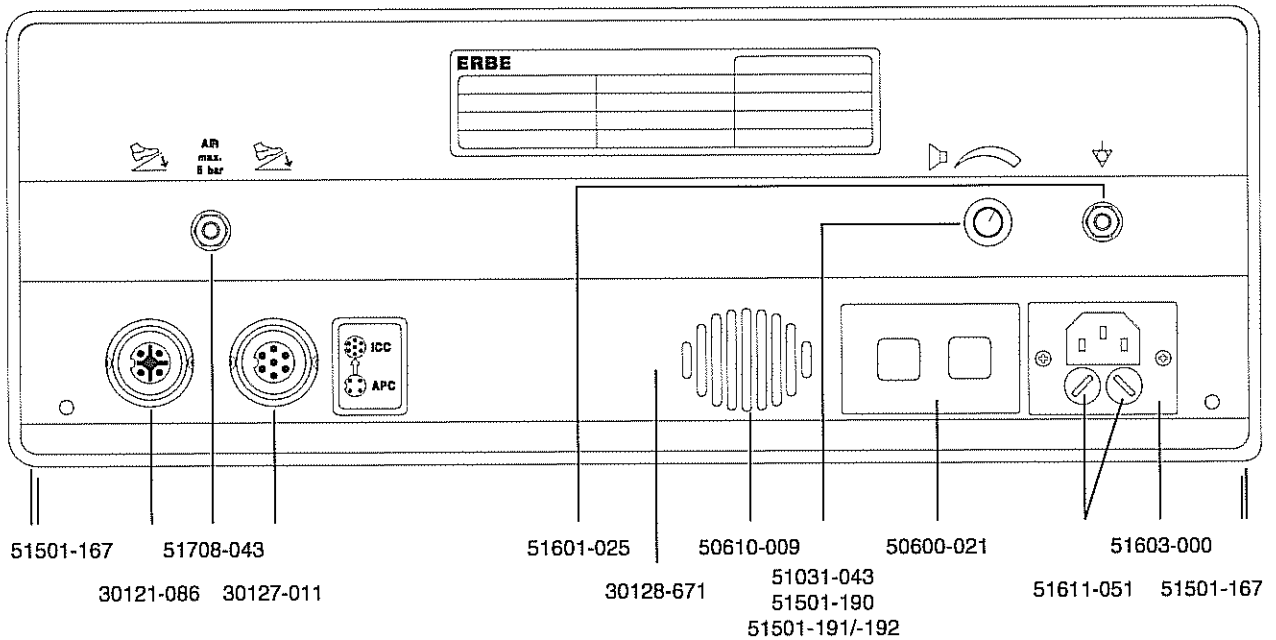
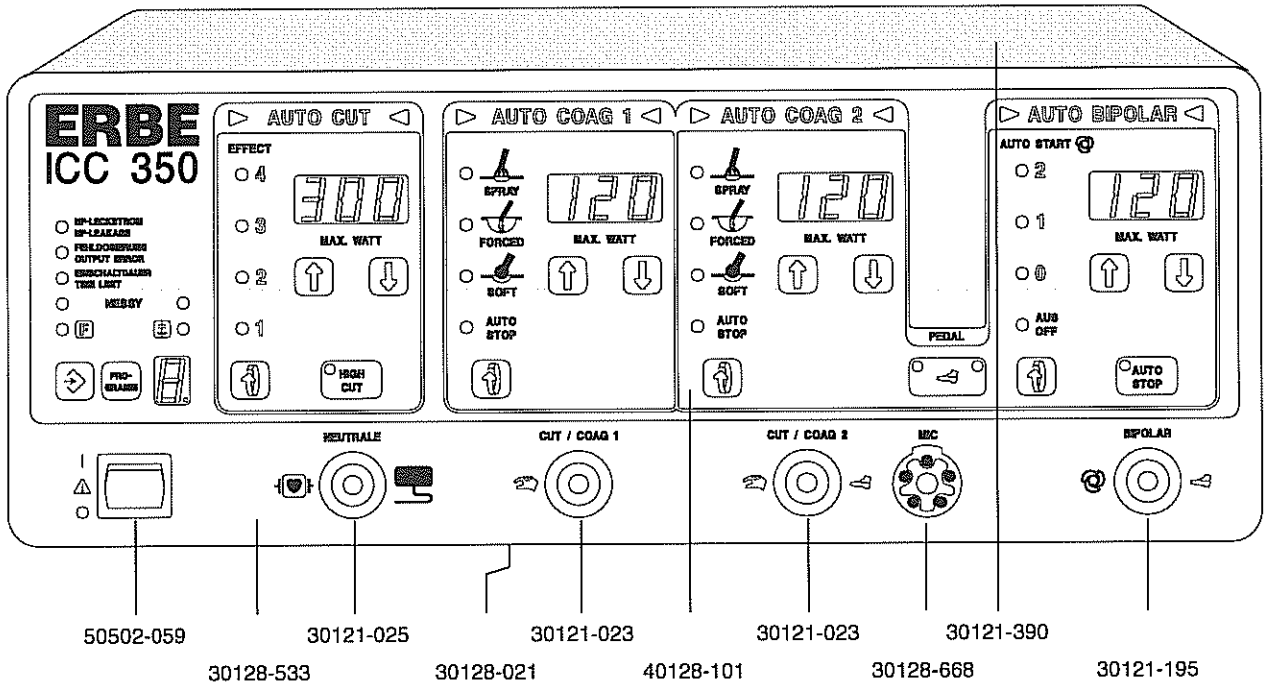

Art.-No. 80116-201
09/2004

ICC 350 Z

10128 -065

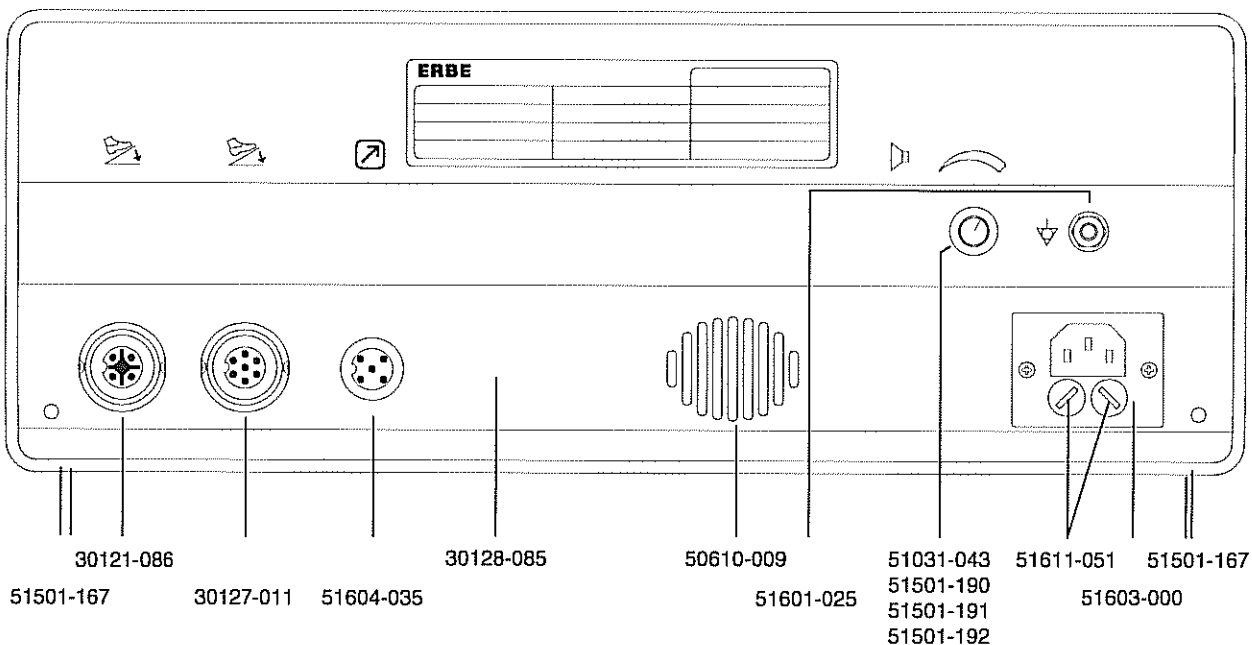
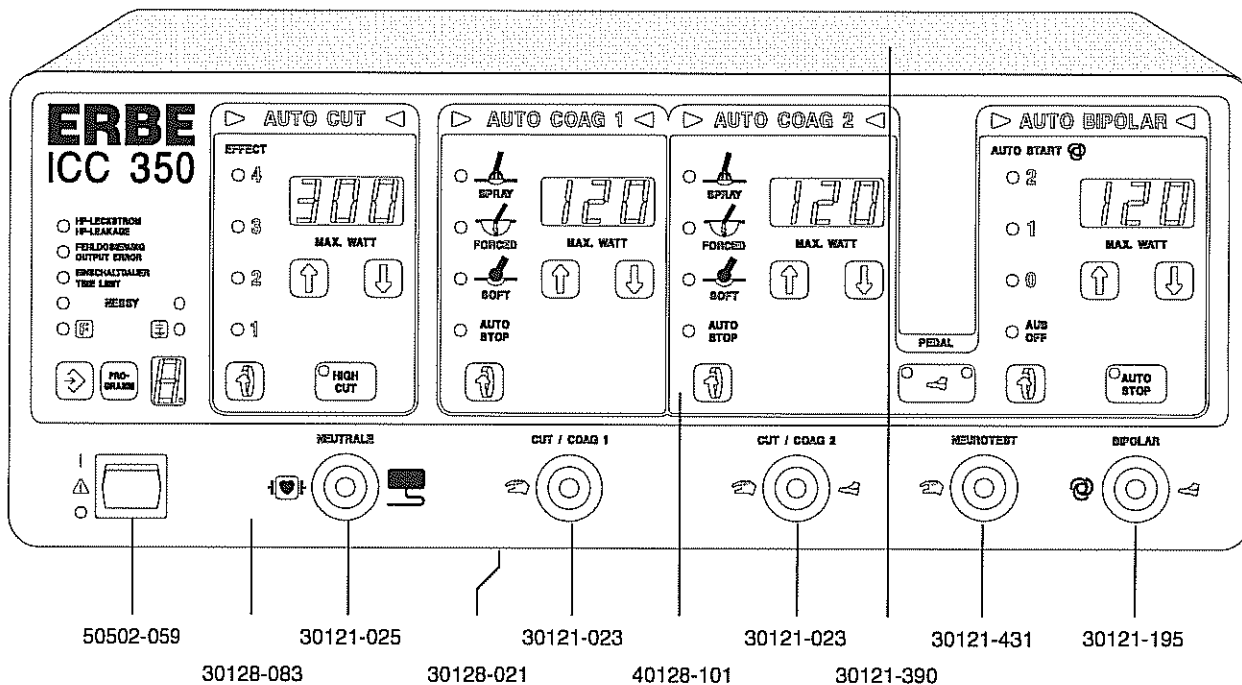

ICC 350 T

10128-066

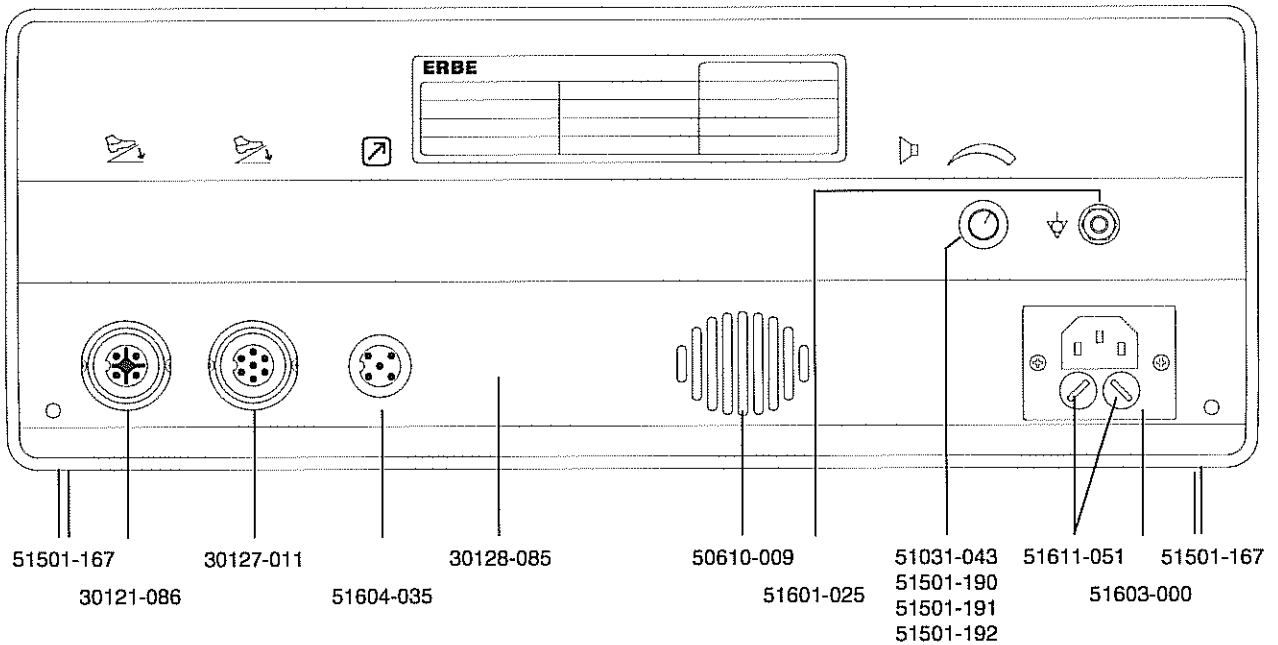
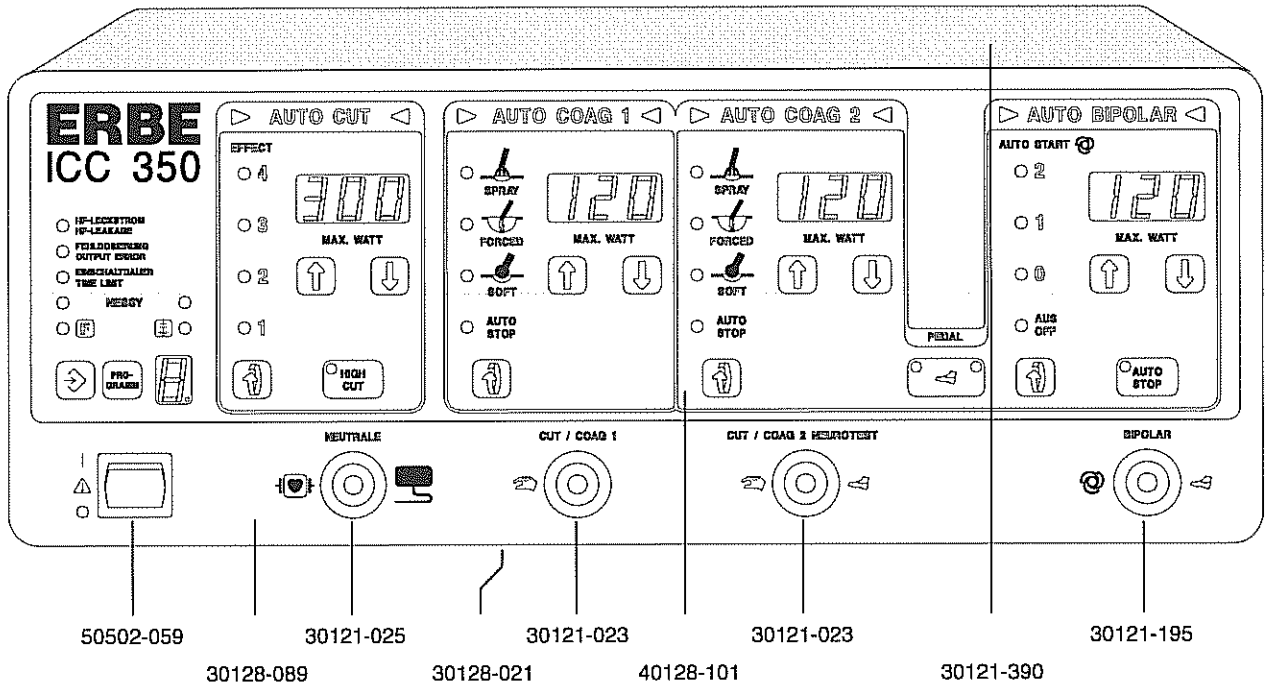

Art.-No. 80116-201
09/2004

ICC 350 M (INT)

10128-083, -310

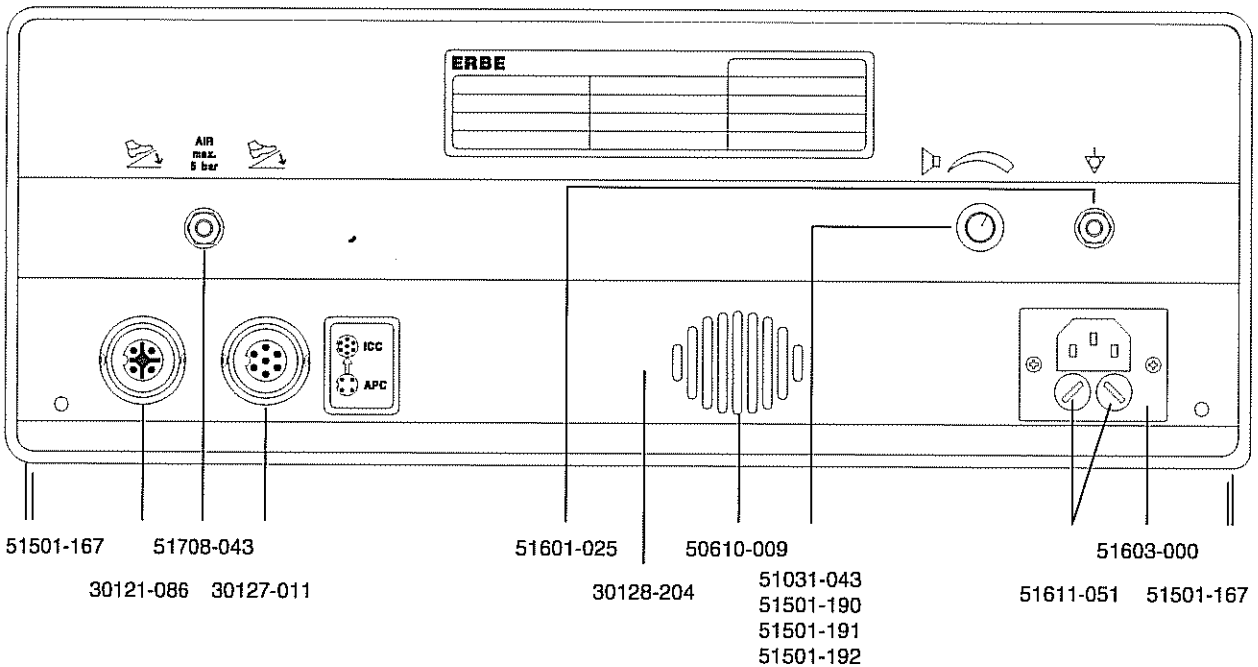
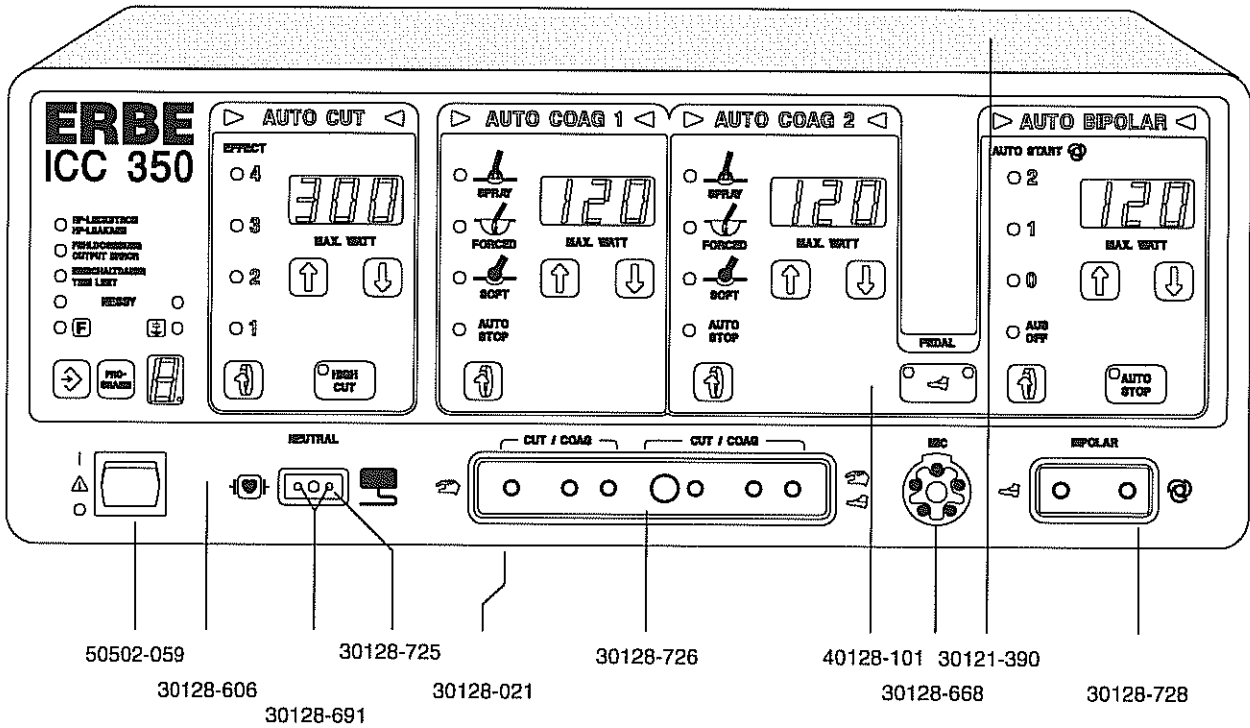

ICC 350 M

10128-080

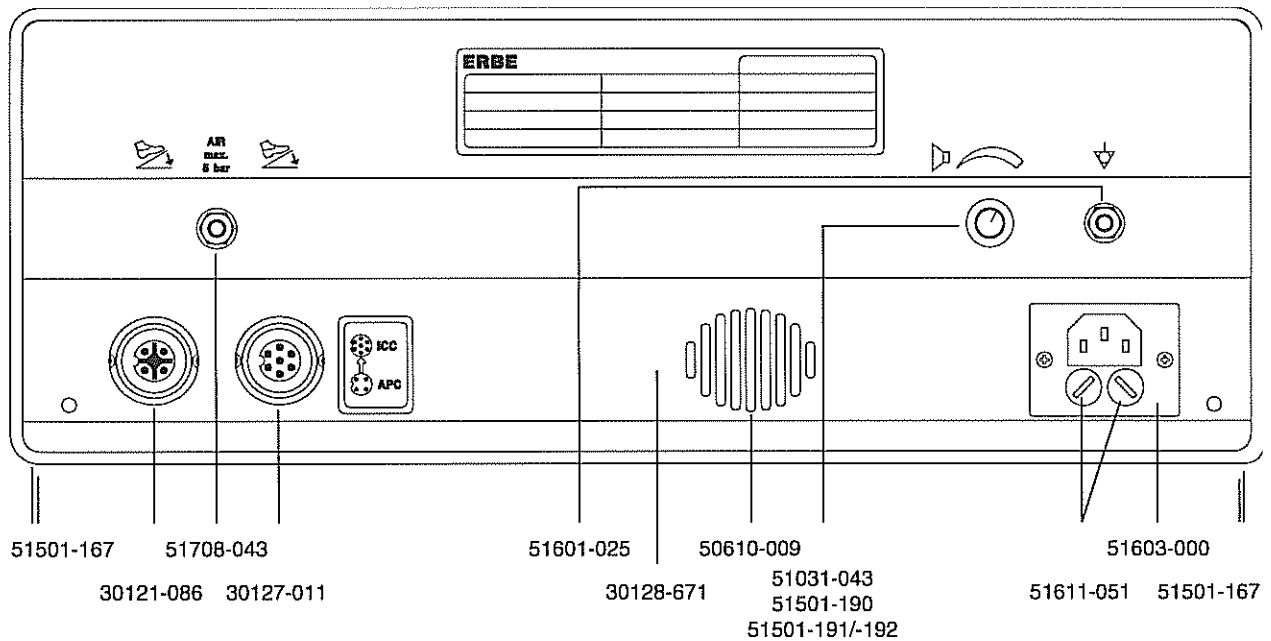
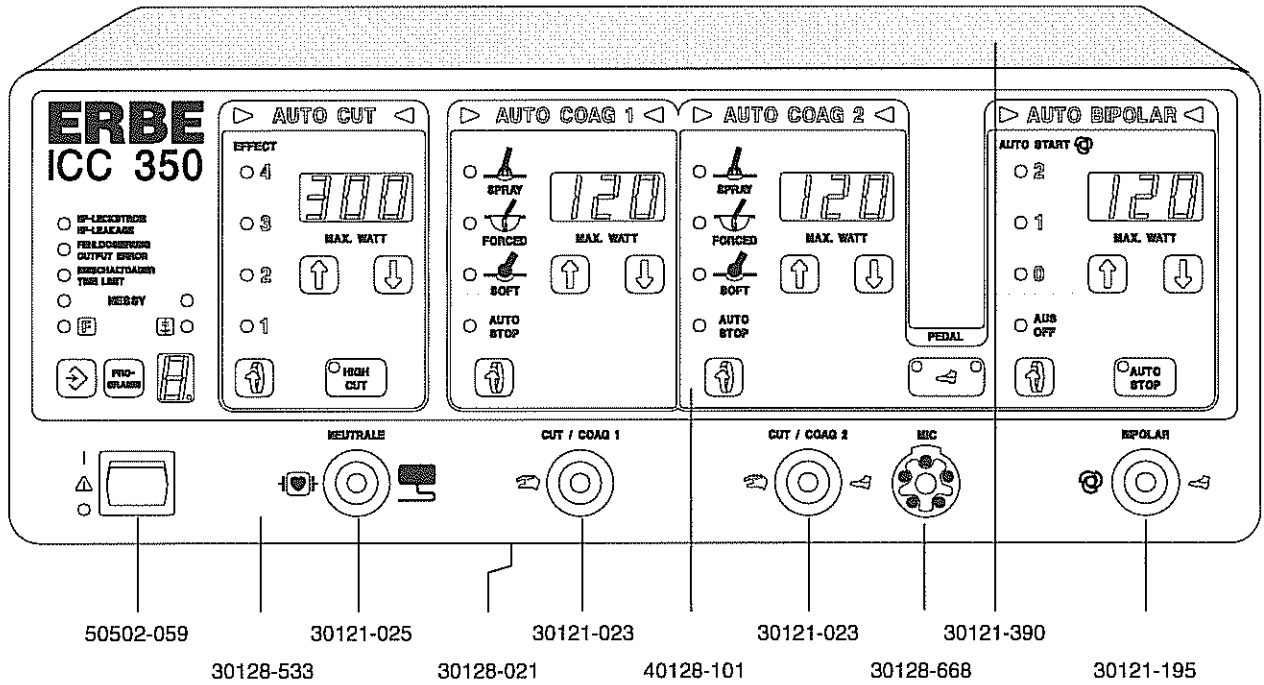

Art.-No. 80716-207
09/2004

ICC 350

Boards

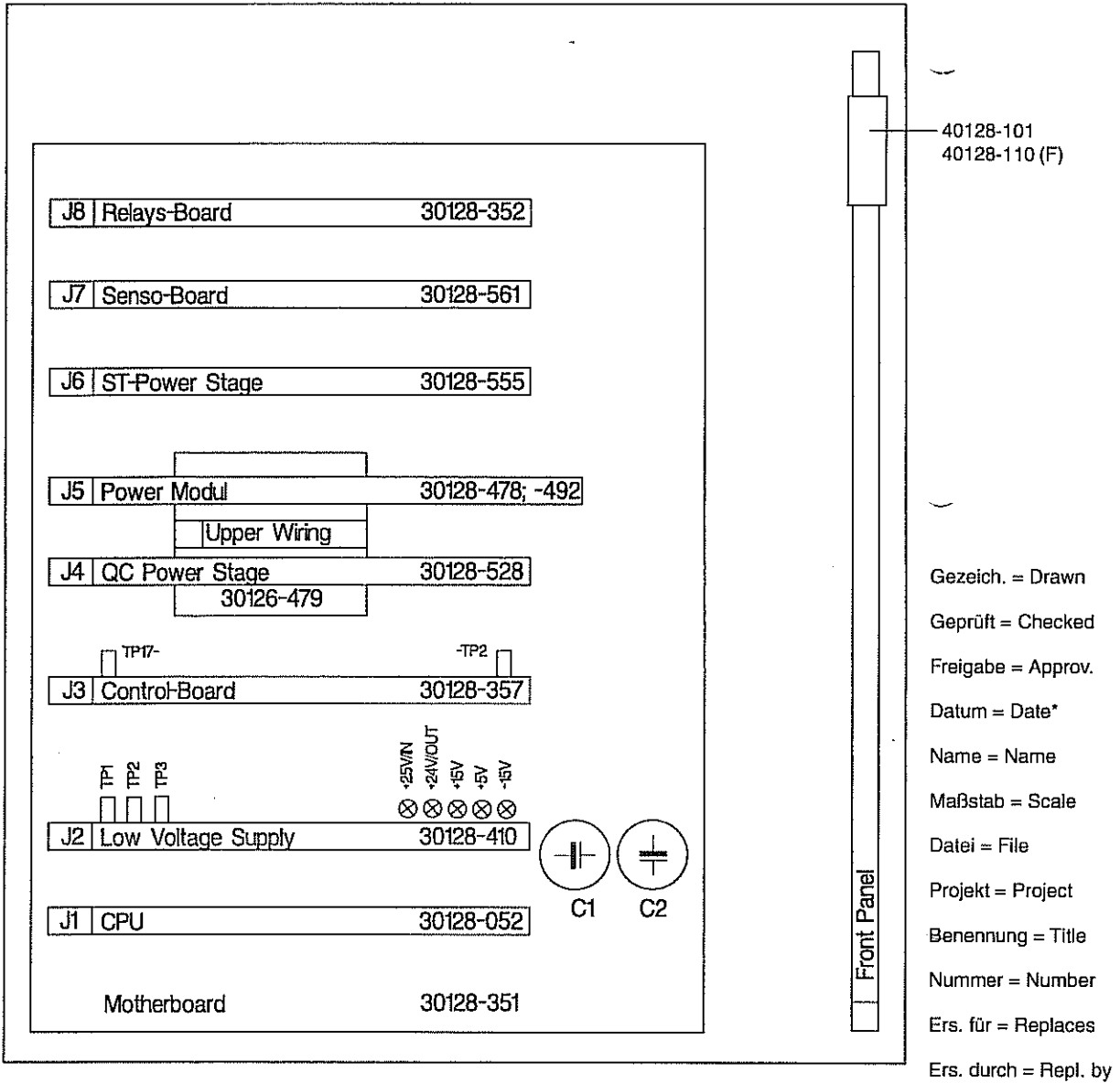

	Datum	Name	Maßstab	Datei	PCBd.ged
Gezeich.	12.96.	Karlsberg	Projekt	V 2.0	
Geprüft			Benennung ICC 350		
Freigabe					
ERBE 72072 Tübingen			Nummer	PCB	
			Ers. für:	Ers. durch:	

Appendix

Abbreviations, Notes, Addresses

B

Appendix

Abbreviations

Notes

Addresses

Abbreviations

The following list summarizes all those abbreviations and symbols which are used in this service manual.

Abbreviation	means	Abbreviation	means
NE	neutral electrode	ϕ	phase angle
	non-split NE	$V_{(p)}$	volts (peak value)
	split NE	$A_{(eff)}$	amperes (r.m.s. value)

Parts lists

This service manual includes no parts lists. However, if you should need to refer to part numbers, please see Appendix A.

Measuring equipment

For a list of recommended measuring equipment for servicing the units ICC 200, ICC 300 and ICC 350, please refer to this service manual (Chapter 1, Test program 16).

Diagrams of electrical dimensions

The diagrams of the electrical dimensions are not shown in this service manual. However, you will find these printed in the instruction manuals for the respective unit.

Any questions?

This service manual has been put together carefully and was subjected to a continuous improvement process during its creation by the Service Department and/or the Development Department at ERBE Elektromedizin. Nevertheless, you may still have questions; additionally, this manual cannot assume to be perfect and completely without error. In such cases, please contact:

Contents, formulation, structure, technical information

Dipl.-Phys. Michael Grosse (Development Dept.)

Tel.: (+49) 70 71 / 755–254

E-mail: mgrosse@erbe-med.de

Technical questions regarding service and the units

Service Manager Roland Bauer (Service Dept.)

Tel.: (+49) 70 71 / 755–454

E-mail: techservice@erbe-med.de

Your notes

ERBE

Elektromedizin

ERBE Elektromedizin GmbH
Waldhörnlestraße 17
72072 Tübingen
Postfach 1420
72004 Tübingen
Telephone: (0049) (0) 70 71 / 755-0
Telefax: (0049) (0) 70 71 / 755-179
E-Mail: sales@erbe-med.de
<http://www.erbe-med.de>

Customer Support
Telephone: (0049) (0)70 71 / 755-123
Telefax: (0049) (0)70 71 / 755-51 23
E-Mail: support@erbe-med.de

Technical Service
Telephone: (0049) (0)70 71 / 755-437
Telefax: (0049) (0)70 71 / 755-189
E-Mail: techservice@erbe-med.de

ERBE Germany

Sales team North-East

Telephone: (0049) (0) 70 71 / 755-404
Telefax: (0049) (0)70 71 / 755-54 04
team-nord-ost@erbe-med.de

Sales team Middle-West

Telephone: (0049) (0) 70 71 / 755-405
Telefax: (0049) (0)70 71 / 755-54 05
team-mitte-west@erbe-med.de

Sales team South

Telephone: (0049) (0) 70 71 / 755-406
Telefax: (0049) (0)70 71 / 755-54 06
team-sued@erbe-med.de

Austria

ERBE Elektromedizin GmbH
Modecenterstraße 14/Top B1
A-1030 Wien
Telephone: (0043) 1-8 93 24 46
Telefax: (0043) 1-8 93 24 46-3
E-Mail: erbe-aut@erbe-med.com

Belgium

ERBE Benelux BVBA
Culliganlaan 1b
B-1831 Diegem
Telephone: (0032) (0)2 403 13 60
Telefax: (0032) (0)2 403 13 59
E-Mail: erbe@erbe.be

China

ERBE Shanghai (China / Hong Kong)
Rep. Office, Room 2806
Shanghai Int. Trade Center
No. 2201 Yan An Road (West)
200336 Shanghai
Telephone: (0086) 21-62 75 84 40
Telefax: (0086) 21-62 75 88 74
E-Mail: erbe@erbechina.com

France

ERBE MEDICAL S.à.r.l.
Z.A.C. Sans Souci
470 Allée des Hêtres
F-69760 Limonest
Telephone: (0033) 4 78 64 92 55
Telefax: (0033) 4 78 66 16 43
E-Mail: erbe@erbe-france.com

Great Britain

ERBE Medical UK, Ltd.
The Antler Complex
2 Bruntcliffe Way, Morley
Leeds LS 27 0JG
West Yorkshire
Telephone: (0044) 11 32-53 03 33
Telefax: (0044) 11 32-53 27 33
E-Mail: sales@erbeuk.com

Netherlands

ERBE Benelux B.V.
Velsenstraat 10
NL-4251 LJ Werkendam
Telephone: (0031) 183-50 97 55
Telefax: (0031) 183-50 07 70
E-Mail: klantenservice@erbe.nl

Poland

ERBE Polska Sp. z o.o.
ul Marconich 8
PL-02-954 Warszawa
Telephone: (0048) 22 642-25 26
Telefax: (0048) 22 642-88 99
E-Mail: sales@erbe.pl

Russia

ERBE Elektromedizin GmbH
Representative Office in Russia
World Trade Center
123610 Moskau
Krasnopresnenskaja nab. 12
Meshdunarodnaja - 2, Büro 1742
Telephone: (007) 095-258 19 05
Telefax: (007) 095-258 19 04
E-Mail: erbe.mow@wtt.ru

Switzerland

ERBE Swiss AG
Fröschenweidstraße 10
CH-8404 Winterthur
Telephone: (0041) 52-2 33 37 27
Telefax: (0041) 52-2 33 33 01
E-Mail: sales@deltamed.ch

USA

ERBE USA, Inc.
2225 Northwest Parkway
USA-Marietta, GA 30067
Telephone: (001) 770-955-44 00
Telefax: (001) 770 955-25 77
Customer Support (+1) 800-778-37 23
E-Mail: sales@erbe-usa.com

