

TECHNICAL MANUAL

PILOT

HYPERBARIC

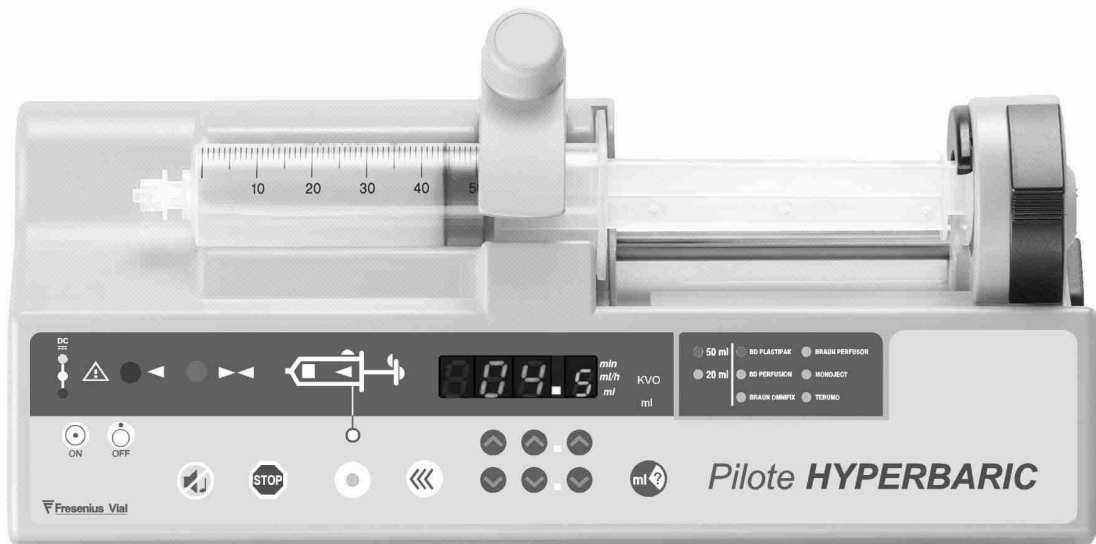

CAUTION :
This document must be used
jointly with the Technical
Manual of the Pilot A2

PILOT HYPERBARIC

This document is an annex to the technical dossier Pilot A2 and C. It describes the technical characteristics of the Pilot HYPERBARIC. Please refer to the global technical documentation of Pilot A2 for maintenance operation (Do not take into account information relative to mains power supply) **

Annex applicable for all serial n° of Pilot HYPERBARIC

Particular conditions are required to operate the Pilot HYPERBARIC for its intended use. Please read the following recommendations and precautions of use described in the user manual of the device.

1.1. Introduction

The principle of functioning of the Pilot HYPERBARIC syringe pump is identical to Pilot A2.

The major difference concerns the power supply of the unit in **12VDC only**. This is to prevent the risk, if linked to mains voltage, of potential sparks that can be generated in case of short circuit. (N.B. Mains power not normally accessible in Hyperbaric Chambers)

For the same safety reasons, linked to potential risk of battery hydrogen degassing, the unit has no internal battery.

Important note: It is highly recommended to proceed to the installation of the external battery delivered with the unit. The device should be powered by a 12Vdc power supply, itself powered by mains from the hospital generator network.

1.2. Installation

The connection to any power supply source should be built outside the hyperbaric chamber (12 Vdc and battery).

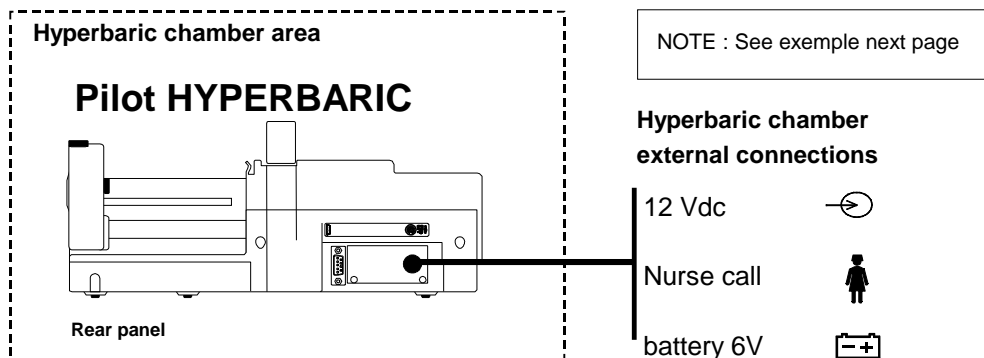

Warning: The device power supply cable should be freely, positioned to prevent being caught or bent and with no pulling traction force.

Verify the locking system of both male and female connectors, from the cord plug and the connector rear panel.

Use the internal hospital protocol for the Pilot HYPERBARIC electric installation inside and outside the hyperbaric chamber (wires trough the chamber, 12 Volts connection...).

12 Vdc power supply should comply with IEC 601-1, e.g.: type EGSTON 12 V 500 mA.

1.3. Wiring of the locking plug

The locking plug should prevent any hazardous disconnection when the device is running with high pressure hydrogen.

Wiring of the locking plug:

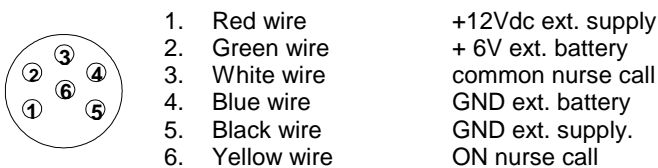

Warning: others cables than the one delivered with the unit can only be used if the working current is 1A minimum.

1.4. Example of hyperbaric external installation

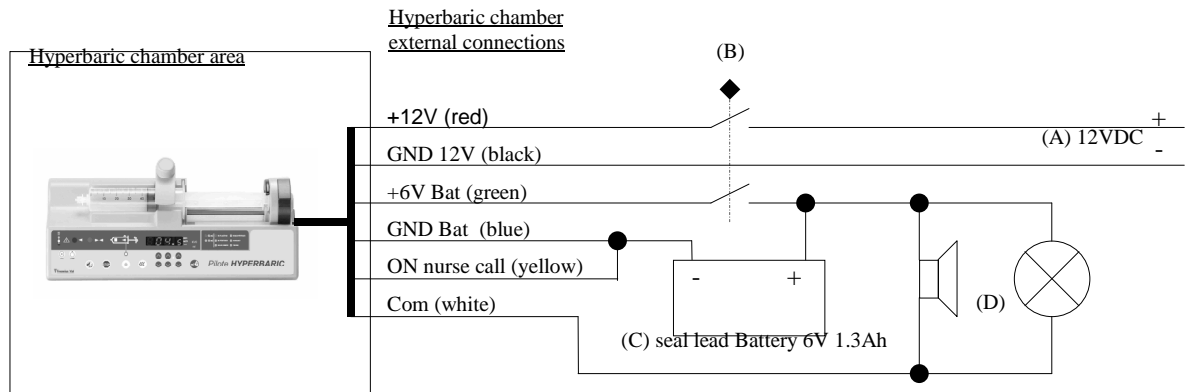

- (A) 12 Vdc power supply should comply with IEC 601-1, e.g.: type EGSTON 12 V 500 mA.
- (B) A protection switch can be **included** in the wiring to allow to shutdown the unit from the outside (definitively stop the infusion) with no need to enter in the hyperbaric chamber.
- (C) The battery, placed outside the hyperbaric chamber, **will allow the infusion to be sustained in case of power** supply failure (A) with no risk of hydrogen degassing inside the hyperbaric chamber, the charging voltage to the battery is managed by the Pilot Pump.
- (D) A remote control **installation improves the alarm detection**, which becomes difficult with the phonic insulation created by the close chamber.
- ◆ **WARNING:** The courant supplied for the remote controlled alarm system should not be able to create sparks when the relay is switching inside the Pilot pump.

1.5. Maintenance

Pilot HYPERBARIC and its internal components support constraints of pressure. Therefore we recommend shortening preventive maintenance period according to the rate/time it is used inside the chamber and the pressure level applied (once a year is a minimum).

Include in the preventive maintenance operation an open device and visual verification protocol to assess components that may be affected by the pressure. Have a particular care of chemical capacitors by looking:



1. At the base: no trace of leak on the PCB.
2. At the top: decompression valve.

This has to be done, even if tests we performed have shown good resistance to pressure variations.

To preserve device autonomy performance, replacement of the external battery should be done every 3 years.

The Pilot HYPERBARIC is equipped with a specific keyboard. Any replacement should be done with the reference in the nomenclature here after, as well as mechanical components (specific grease).

1.6. 12 Vdc and external battery functioning control

1. Connect the device to a 12 Vdc power supply and verify that the indicator ● yellow is lighting continuously.
2. Disconnect the 12 Vdc power supply and verify that the battery indicator  green is lighting continuously.
3. From the external battery connector, connect the device to well regulated DC power supply set-up at **6,3 V** (Important : respecter polarities "+/-").
4. Turn on the device with ON key.
5. Install and select a syringe. select a flow rate and confirm.
6. Lower the power supply voltage and verify that pre-alarm "Low battery" is triggered from **5,8 V to 6 V**, with battery alarm  red light indicator and pre-alarm ● orange light indicator.
7. Lower the power supply voltage and verify that alarm "Low battery" is triggered from **5,6 V to 5,8**, with battery alarm  red light indicator and alarm ● red light indicator.

Remark: in case upper values are not respected, report to standard calibration procedure EtA 4 (chapter 3, paragraph 3.2.1 of Pilot technical documentation).

1.7. Specific technical recommendations

The use of silicone grease is prohibited (risk of explosion with oxygen). For any work requiring use of grease, use a type of grease guarantee for use with oxygen under pressure condition.

Use exclusively the battery type provided with the device: battery 6 Volts 1.1 / 1.3 Ah.

In case of specific component replacement or sub assemblies, make sure about device part compatibility (e.g.: motor, keypad, front panel sticker, utilisation of grease,...).

During maintenance, verify that specific « HYPERBARIC » labels are at the right location.

Do not remove the mains hole cover.

1.8. External battery autonomy Test

Battery autonomy is 7 hours average (minimum 5 hours) for a device running with a B-D Plastipak 50 ml at 5 ml/h flowrate or > 1 hours at 120 ml/h.

The low battery pre-alarm indicate the user a remaining autonomy of approximately 60 minutes (at 5 ml/h) before complete stop of the infusion (Low battery alarm).

Charging for battery autonomy recovery is minimum 16 hours (100% of capacity).

1.9. Nurse call

The relay **RL2**, with two **contacts (pin 3 & 6)** and leads in the supply cable, allows the alarm battery light indicator functioning:

- Normal alarm function: red indicator light up.
- Pre-alarm function: red indicator blinking.

1.10. Pilot HYPERBARIC keyboard

The keyboard (free air path) of the Pilot HYPERBARIC is specially design for hyperbaric environment.

Important: for any change, do not use another keypad than the specific one for Pilot HYPERBARIC.

1.11. Lubrication of the mechanism with Grease

Important: use only a type of grease guaranteed for use with oxygen under pressure condition

Part to lubricate:

1. The two guides diameter 6mm of the mechanical bloc.
2. The lead screw.
3. The top of the rack at the guide area.
4. The teeth of the rack-and-**pinion** (all the length).
5. The spring cavity of the two half-nut disengagement system.
6. The inside of mechanical bloc.

1.12. Use out of Hyperbaric Chamber or with low pressure and no oxygen

If the device is to be use with no concentrated oxygen and pressures below the functioning value recommended by battery manufacturers (30 meters of water), the battery can be relocated inside the device and connect to the PCB with the standard connection from J4 to battery leads. Then the actual link from J4 to pin 2 & 4 of the female connector should be removed. This type of use is not recommended due to the risk of **the device being used in a Hyperbaric Chamber**.

1.13. Specific nomenclature

The following spare parts are specific to the Pilot HYPERBARIC and parts from another device or device list should never be used for the maintenance of the Pilot HYPERBARIC pump.

Reference	identifier	Designation
168106		Pilot HYPERBARIC Front panel
167705		Keypad A2 CE2 Free air entry (active Part)
199195		PILOT HYPERBARIC wire lockable connector (12Vdc, external battery, nurse call)
167531		Wired back plug panel (white) Pilot HYPERBARIC
170653		Female lockable connector (not wired)
170654		male lockable connector (not wired)
167530		Motor-reducer Pilot HYPERBARIC (wired)
167503		Upper housing (white)
167511		Lower housing (white)
167513		Battery door (white)
167521		Pusher housing (white)
167517		Pusher cover (white)
167514		guide rail of the pusher (white)
167516		Syringe holder (white)
167520		buzzer plastic pipe (white)
167682		Sticker diameter 17.5 (Syringe holder)
199254		pusher kit Pilot A/A2 (white)
167499		Mains plug hole cover
167686		Syringe list
167760		External "Warning Hyperbaric" label
167723		Internal "Warning Hyperbaric" label
167889		Door sticker 6 (rear)
174019		External battery
169538		Pilot HYPERBARIC user guide
171326		Oxygénoex S4 grease for Pilot HYPERBARIC

1.14. Wiring schematic of the Pilot Hyperbaric

Designation	FV.REF	DESIGN. REF	Rev.
Rear door wiring for PILOT HYPERBARIC (French) (1/1)	A301725		A

