

## PILOT Delta



Serial N° 17522534 to...





<b>1 Overview .....</b>	<b>7</b>
<b>1.1 General .....</b>	<b>7</b>
<b>1.2 Overview diagram .....</b>	<b>8</b>
<b>1.3 Precautions to be taken before use.....</b>	<b>9</b>
<b>1.4 Internal safety features .....</b>	<b>9</b>
<b>1.5 Technical characteristics .....</b>	<b>9</b>
1.5.1 Electrical.....	9
1.5.2 Electronics.....	9
1.5.3 Mechanical characteristics .....	9
1.5.4 Conformity, standards .....	10
<b>2 Description and operation .....</b>	<b>11</b>
<b>2.1 Physical description .....</b>	<b>11</b>
2.1.1 The display board and the front panel.....	12
2.1.2 CPU board .....	14
2.1.3 The power supply board and the battery.....	17
2.1.4 Mechanical gear base unit .....	20
2.1.5 Mechanical plunger unit .....	20
<b>2.2 Functional description.....</b>	<b>21</b>
2.2.1 Syringe control and maintenance sub-assembly .....	21
2.2.2 Motorisation sub-assembly .....	21
2.2.3 External connection sub-assembly .....	21
<b>3 Description of the menus .....</b>	<b>23</b>
<b>3.1 Pressure parameter configuration menu .....</b>	<b>23</b>
3.1.1 Access to menus.....	23
3.1.2 <i>PrES.1</i> , memorisation of the pressure limit.....	24
3.1.3 <i>PrES.2</i> , memorisation of the maximum pressure.....	25
3.1.4 <i>PrES.3</i> , pressure drop detection threshold .....	25
<b>3.2 Configuration menu of the basic operation parameters .....</b>	<b>27</b>
3.2.1 Access to menus.....	28
3.2.2 <i>PrR.1</i> , configuration of the flow rate memorisation type.....	29
3.2.3 <i>PrR.2</i> , configuration of the syringe selection type.....	29
3.2.4 <i>PrR.3</i> , maximum flow rate that may be selected on the keyboard.....	29
3.2.5 <i>PrR.4</i> , configuration of the list of syringes that may be selected .....	30
3.2.6 <i>PrR.5</i> , configuration of the compulsory priming .....	30
3.2.7 <i>PrR.6</i> , configuration of the rapid infusion start-up.....	31
3.2.8 <i>PrR.7</i> , configuration of the KVO flow rate .....	31
3.2.9 <i>PrR.9</i> , configuration of the RS232 communication speed .....	32
3.2.10 <i>PrR.A</i> , configuration of the empty syringe mode.....	32
3.2.11 <i>PrR.b</i> , configuration of the frequency of preventive checks.....	33
3.2.12 <i>PrR.c</i> , configuration of the protocols memorised.....	33
3.2.13 <i>PrR.d</i> , configuration of the fin detection mode.....	34
3.2.14 <i>PrR.E</i> , configuration of the flow rate memorisation mode programmed bolus..	34
3.2.15 <i>PrR.F</i> , configuration of the bolus flow memorisation mode.....	35

3.2.16	<i>PAR</i> .G, configuration of the flow rate mode.....	35
3.2.17	<i>PAR</i> .J, configuration of the mains disconnection signal .....	36
3.2.18	<i>PAR</i> .P, configuration of the user service name.....	36
<b>3.3</b>	<b>Calibration menu.....</b>	<b>37</b>
<b>3.4</b>	<b>ASS test menu.....</b>	<b>39</b>

## **4 Preventive maintenance..... 41**

<b>4.1</b>	<b>Recommendations.....</b>	<b>41</b>
<b>4.2</b>	<b>Maintenance schedule.....</b>	<b>41</b>
4.2.1	Use beyond the framework of the departmental order.....	41
4.2.2	Use within the framework of the departmental order .....	41
<b>4.3</b>	<b>Checks .....</b>	<b>43</b>
4.3.1	Test access .....	43
4.3.2	Visual check .....	44
4.3.3	Running time and servicing inspection date.....	44
4.3.4	Indicator lights check.....	44
4.3.5	Keyboard check .....	45
4.3.6	Checking the battery voltage.....	46
4.3.7	Testing the last 10 alarms .....	46
4.3.8	Total running time check .....	47
4.3.9	TTL serial link test .....	47
4.3.10	RS 232 serial link check.....	47
4.3.11	Checking the force sensor .....	48
4.3.12	Checking the software version.....	48
4.3.13	Checking the ADC.....	48
4.3.14	Checking the position sensor .....	49
4.3.15	Displaying the calibration values.....	49
4.3.16	Checking the syringe clamp .....	50
4.3.17	Checking the last 10 events before cut-off.....	50
4.3.18	Checking the library .....	51
4.3.19	Checking the disengagement.....	51
4.3.20	Checking the fin detection system .....	51
4.3.21	Checking the anti-siphon arm .....	51
4.3.22	Checking backpressure.....	52
4.3.23	Checking the end of infusion pre-alarm .....	53
4.3.24	Checking the linearity.....	54
4.3.25	Checking mains/battery operation.....	54
4.3.26	Battery autonomy test .....	55
4.3.27	Continuity test .....	55
4.3.28	Regular inspection sheet.....	57
<b>4.4</b>	<b>Flow rate control.....</b>	<b>59</b>
4.4.1	Measurement with a computer.....	59
4.4.2	Measurement with scales.....	61
4.4.3	Measurement using a test tube.....	63
<b>4.5</b>	<b>Cleaning and disinfection .....</b>	<b>65</b>
<b>4.6</b>	<b>Storage.....</b>	<b>66</b>

<b>5</b>	<b>Diagnosis .....</b>	<b>67</b>
5.1	Troubleshooting .....	67
5.2	Error messages .....	69
<b>6</b>	<b>Operation sheets .....</b>	<b>71</b>
N°1,	Procedure: Display and central unit boards .....	73
N°2,	Procedure: Syringe clamp .....	77
N°3,	Procedure: Syringe detection system .....	79
N°4,	Procedure: Motor + Opto + Disk .....	85
N°5,	Procedure: Pressure sensor .....	87
N°6,	Procedure: Plunger advance control potentiometer .....	91
N°7,	Procedure: Plunger cover and/or disengagement lever + anti-siphon arm .....	93
N°8,	Procedure: Power supply board .....	95
N°9,	Procedure: Battery holder and battery .....	97
N°10,	Procedure: Rear plug support .....	99
N°11,	Procedure: Ribbon cable winding kit .....	101
N°12,	Procedure: Syringe head detection plunger kit .....	105
N°13,	Procedure: Centering ring kit .....	109
N°14,	Procedure: Flex circuit and tube kit .....	113
N°15,	Procedure: Upper and lower cases .....	119
N°16,	Procedure: Display and central unit boards .....	121
<b>7</b>	<b>Calibration .....</b>	<b>123</b>
7.1	Calibration procedure .....	123
7.1.1	Calibration access .....	123
7.1.2	<b>ÉÉRL.4</b> Calibration of the 3 battery voltage levels .....	124
7.1.3	<b>ÉÉRL.6</b> Calibration of the position sensor. ....	124
7.1.4	<b>ÉÉRL.9</b> Calibration of the force sensor .....	125
<b>8</b>	<b>Spare parts catalogue .....</b>	<b>127</b>
8.1	Upper case .....	127
8.2	Lower case .....	129
8.3	Plunger unit .....	131
8.4	Mechanical gear base .....	135



---

# 1 Overview

## 1.1 General

---

The **Pilot Delta** is a syringe pump intended for the infusion of intravenous agents.

A library of intravenous agents and administration protocols such as the hands-free Bolus pre-setting, in mass units, secure and simplify infusions in operating units. The occlusion pre-alarm and the catheter extension disconnection alarm contribute to making the equipment the ideal instrument for administration of agents with short elimination delays.

Associated with the MASTER TCI or the MASTER PCA, the wide range of **Pilot Delta** applications include intravenous anaesthesia with concentration objectives (AIVOC), patient controlled analgesia, sedation or monitored curarisation.

## 1.2 Overview diagram

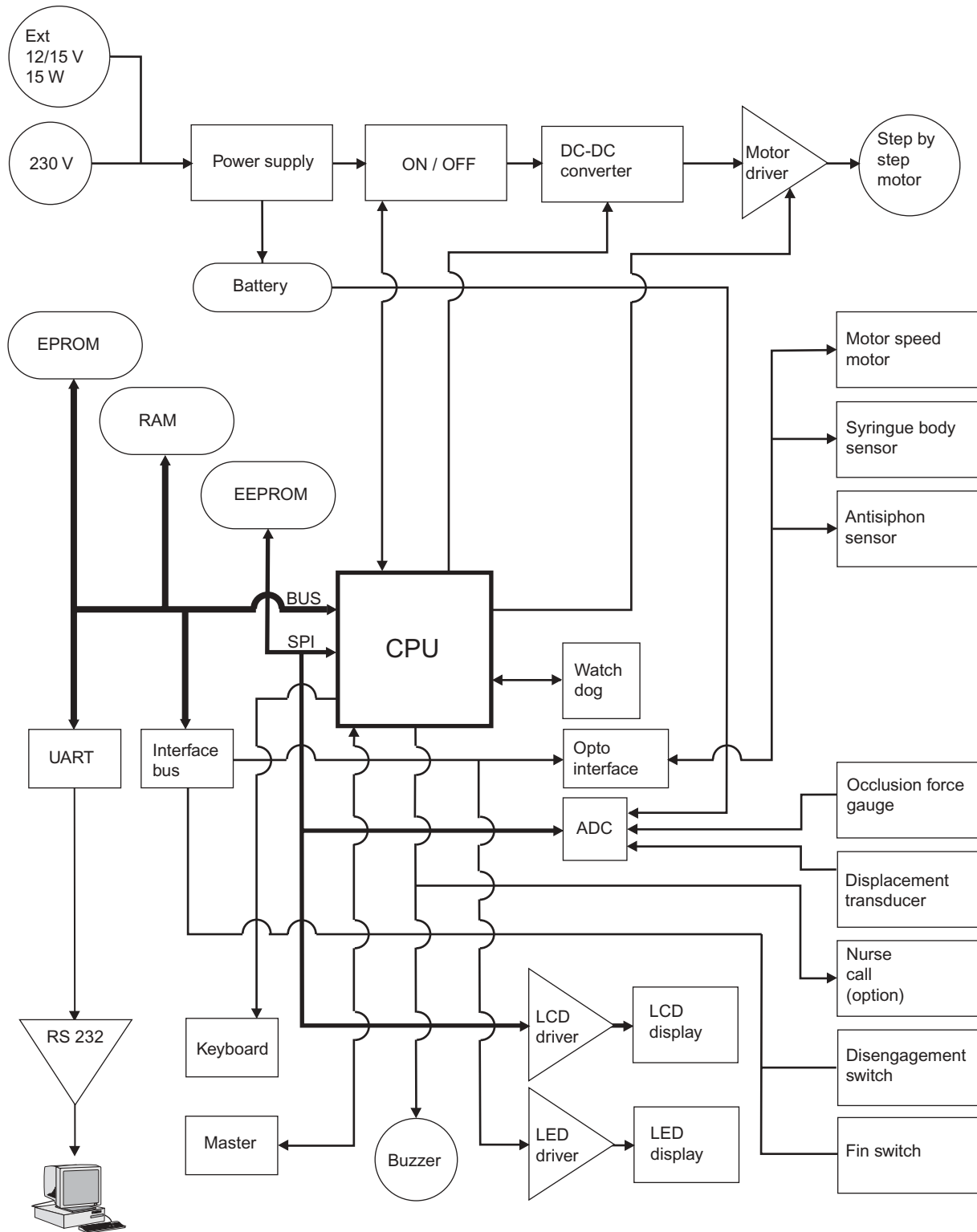



---

## 1.3 Precautions to be taken before use

---

The symbol  shown in the Quick Start Guide recommends that the manual should be read in full in accordance with standard EN 60601-1.

**Fresenius Vial** may in no case be held responsible for medical problems or any other problems resulting from inadequate use of the equipment.

Refer to the User's Guide for further details.

---

## 1.4 Internal safety features

---

As soon as it is switched ON, the equipment activates a continuous function inspection system. Any internal failure or any problem in the usage procedure is detected immediately. Nevertheless, abnormal operation of the equipment with no obvious cause must always be reported to the qualified technicians in your organization or our After Sales service.

If a fault occurs, an alarm is activated for any flow rate deviation of  $\pm 5\%$  in comparison with the normal flow rate.

A second check activates an alarm in the event of deviation of 1 ml in comparison with the anticipated infused volume, or if a flow rate deviation of  $\pm 20\%$  is identified. The alarm is triggered by the deviation detected first.

The **Pilot** is fitted with an internal battery to continue operation in the event of a power cut. Furthermore, a safety fuse protects the mains from further disturbance.

---

## 1.5 Technical characteristics

---

### 1.5.1 Electrical

---

- Power supply: 230 V - 50-60 Hz.
- Max. consumption : 23 VAC.
- Fuse F2: 100 mA 250 V IEC 127.
- Battery: 6 V - 1.1 Ah or 1.3 Ah.
- External power supply: 12 - 15 V DC - 15 W.

### 1.5.2 Electronics

---

The **Pilot** syringe pump is fitted with 3 circuit boards:

- Motor power supply and control board.
- CPU board.
- Keyboard display board.

### 1.5.3 Mechanical characteristics

---

- Overall dimensions H x W x D: 120 x 330 x 155 mm.
- Weight: 2.2 kg approx.

### 1.5.4 Conformity, standards

---

- In compliance with the European Directive 93/42 EEC related to Medical Equipment: CE0459.
- In compliance with the European Directive 89/336 EEC: Electromagnetic compatibility.
- Compliant with the standards EN 60601,1 and PrEN60601-2-24.
- Protection against leakage currents: CF type.
- Protection against electric shock: Class II.
- IP34 : protection against when ingress of liquid.

## 2 Description and operation

### 2.1 Physical description

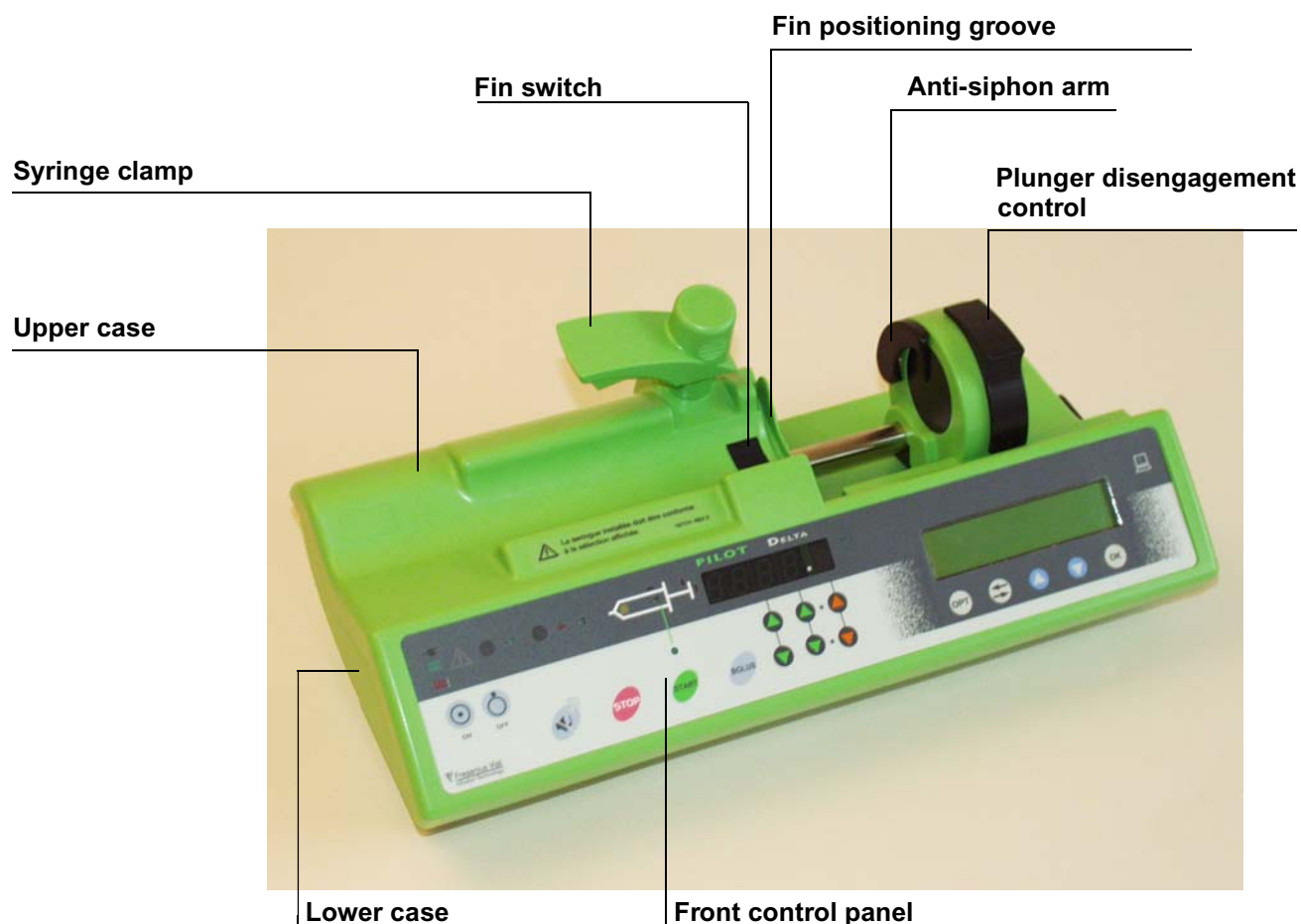

The **Pilot Delta** is composed of an upper case and a lower case.

- The upper case holds the syringe clamp and contains:
  - A display board associated with the front control panel.
  - A CPU board.
- The lower case contains:
  - A power supply board and a storage battery.
  - A mechanical base unit.
  - A plunger unit.

## 2.1.1 The display board and the front panel

The display board is mounted under the front control panel and is fitted with all the items required for man-machine interaction.

- Input keyboard.
- Control lamps and overview diagrams.
- 8-segment display units.
- LCD screen.

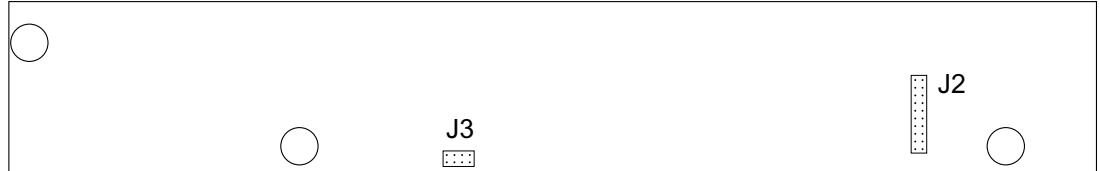

*Solder side display board.*

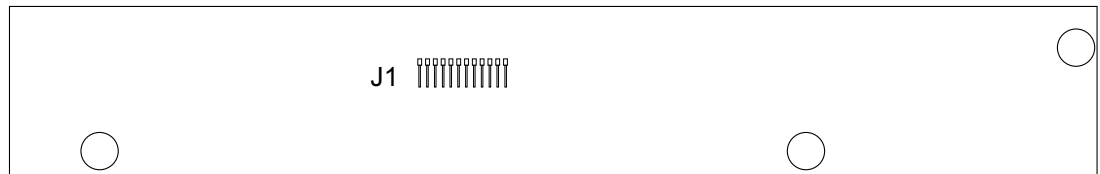

*Component side display board.*

This board is connected to the different items of equipment by means of connectors.

### J2 connector to CPU board

Pin	Description	
1	SEG0 display matrix	Line 1
2	SEG1 display matrix	Line 2
3	SEG2 display matrix	Line 3
4	SEG3 display matrix	Line 4
5	SEG4 display matrix	Line 5
6	SEG5 display matrix	Line 6
7	SEG6 display matrix	Line 7
8	SEG7 display matrix	Line 8
9	COL1 display matrix	Column 1
10	COL2 display matrix	Column 2
11	COL3 display matrix	Column 3
12	LED control FAIL	Fail
13	RDCRT display controller writing control	
14	LIG1 keyboard interface	Line 1
15	LIG2 keyboard interface	Line 2
16	LIG3 keyboard interface	Line 3
17	LDSECT lighting control	Mains LED
18	+5V power supply	
19	VBAT power supply	
20	GND power supply	

### J1 connector to keyboard

Pin	Description
1	Column 1
2	Column 2
3	Column 3
4	Column 4
5	Column 5
6	Column 6
7	Line 1
8	Line 2
9	Line 3
10	Ton
11	Toff
12	Gnd power supply

### J3 connector to CPU board

Pin	Description
1	Ton ON key
2	Toff OFF key
3	SI controller Busy
4	Clk SPI bus
5	CSLCD LCD display unit controller validation
6	BUZZER buzz control
7	Vbat power supply
8	Gnd power supply

**Note:**Board diagrams are available on request; please contact our After Sales service. Refer to "Useful addresses" on the last page.

## 2.1.2 CPU board

The CPU board holds an 80C32 microcomputer. It is mounted and connected to the display board by connectors J4 and J5.

A ribbon cable connects the board to a power supply board by means of a connector J3.

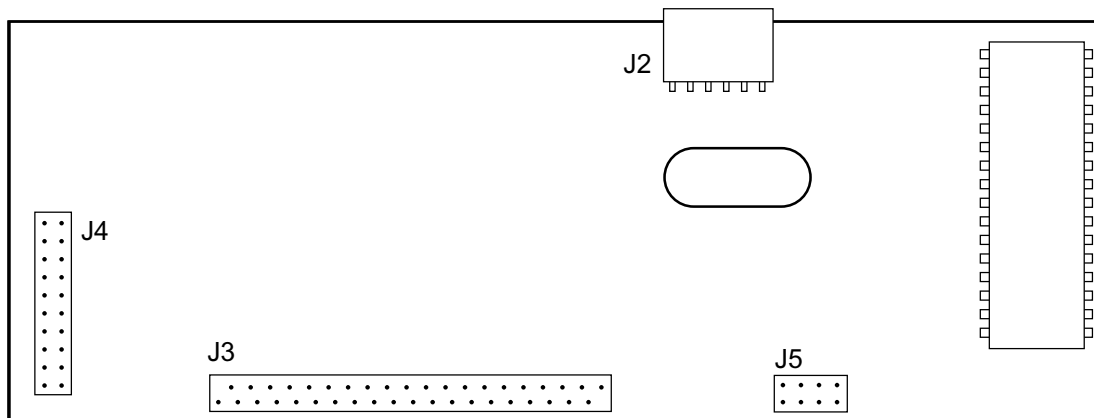

*CPU board*

### J2 connector to fin detection switch and syringe detection opto-electronic sensor

Pin	Description
1	Ground
2	Fin contact
3	Opto anode diode +5V
4	Common points between cathode diode and opto 1 and opto 2 transistor emitters.
5	Opto 1 transistor collector
6	Opto 2 transistor collector

### J3 connector to power supply board

Pin	Description
1	+5V controlled power supply
2	Gnd power supply
3	+Vbat power supply
4	Gnd power supply
5	Phase A motor control
6	Phase B motor control
7	Phase C motor control
8	Phase D motor control
9	I signal motor control
10	Boost signal motor control
11	Sopt1 opto rotation motor output
12	Sopt2 anti-siphon opto output
13	Apinf nurse call independent of the buzzer signal
14	Cdopt1 motor rotation opto control
15	Cdopt2 anti-siphon opto control
16	Off signal, off key pressed
17	Sect mains power supply on signal
18	Cdalim power cut signal

### J3 connector to power supply board

Pin	Description
19	Ldsect mains LED control
20	Rts request to send
21	Deb/off disengagement signal
22	Cts clear to send
23	Occ/off occlusion signal
24	Buz nurse call relay control
25	Eoc end of adc conversion
26	Csadc selection spi adc bus
27	Clk clock spi adc bus
28	Si data in spi adc bus
29	So data out spi adc bus
30	Cdana analogue sensor power supply control
31	Rx2 receive data ttl
32	Tx2 transmit data ttl
33	Txd1 transmit data ttl
34	Rxd1 receive data ttl
35	Ton ON key
36	Toff OFF key
37	+Vbat power supply
38	Gnd
39	+5V
40	Gnd

### J4 connector to keyboard

Pin	Description	
1	Seg1 display matrix and LCD display unit control	Line 1
2	Seg2 display matrix and LCD display unit control	Line 2
3	Seg3 display matrix and LCD display unit control	Line 3
4	Seg4 display matrix and LCD display unit control	Line 4
5	Seg5 display matrix and LCD display unit control	Line 5
6	Seg6 display matrix and LCD display unit control	Line 6
7	Seg7 display matrix and LCD display unit control	Line 7
8	Seg8 display matrix and LCD display unit control	Line 8
9	Col1 display matrix and keyboard	Column 1
10	Col2 display matrix and keyboard	Column 2
11	Col3 display matrix and keyboard	Column 3
12	Fail diode fail control	
13	Rdcrt display controller writing control	
14	Lig1 keyboard interface	Line 1
15	Lig2 keyboard interface	Line 2
16	Lig3 keyboard interface	Line 3
17	Ldsect mains LED control	
18	+5V power supply	
19	Vbat power supply	
20	Gnd power supply	

### J5 connector to display board

Pin	Description
1	Ton ON key
2	Toff OFF key
3	SI controller bus Busy
4	Clk spi bus
5	Cslcd LCD display unit controller validation bus
6	Buzz buzzer control
7	Vbat power supply
8	Gnd power supply

**Note:**Board diagrams are available on request; please contact our After Sales service. Refer to "Useful addresses" on the last page.



### 2.1.3 The power supply board and the battery

The power supply board is mounted on the bottom of the lower case. It supplies all electronic parts using the mains 230 V AC or the external 12 V DC. It also provides electrical supply to the 1.2 or 1.3 Ah battery.

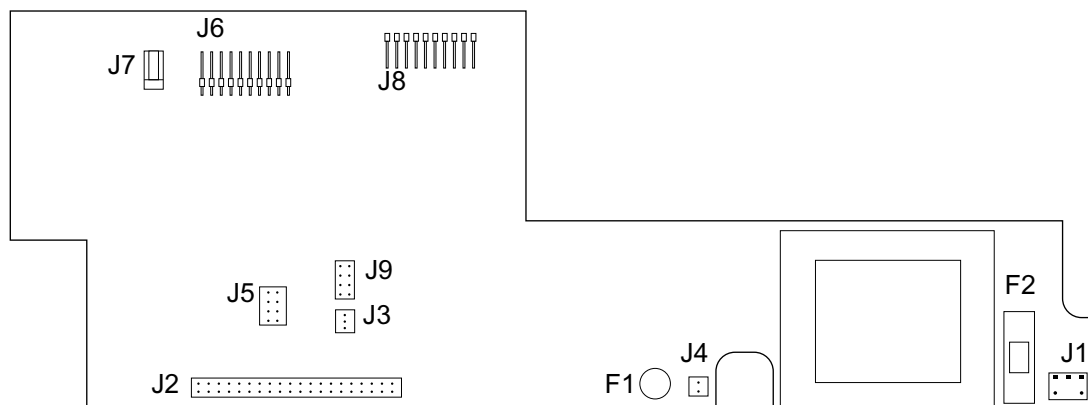

*Power supply board.*

This board is connected to the different items of equipment by means of connectors.

#### J1 connector to mains power supply board

Pin	Description
1	Phase
2	Neutral

#### J2 connector to CPU board

Pin	Description
1	+5V controlled power supply
2	Gnd power supply
3	+Vbat power supply
4	Gnd power supply
5	Phase A motor control
6	Phase B motor control
7	Phase C motor control
8	Phase D motor control
9	I signal motor control
10	BOOST signal
11	Sopt1 opto rotation output module
12	Sopt2 opto anti-siphon output module
13	N.U
14	Cdopt1 opto rotation control module
15	Cdopt2 opto anti-siphon control module
16	Off off key pressed on the ON/OFF button
17	SECT mains supply presence signal
18	CDALIM power cut signal
19	LDSECT mains LED control
20	CTS clear to send
21	DEB/OFF disengagement signal active at 0

### J2 connector to CPU board

Pin	Description
22	RTS request to send
23	OCC/OFF occlusion signal active at 0
24	BUZ nurse call relay control
25	EOC end of ADC conversion
26	CSADC SPI ADC bus select
27	CLK SPI ADC bus clock
28	SI data IN SPI ADC bus
29	SO data out SPI ADC bus
30	CDANA analogue sensors power supply control
31	RX2 TTL receive data
32	TX2 TTL transmit data
33	TXD1 TTL transmit data
34	RXD1 TTL receive data
35	Ton ON key
36	Toff OFF key
37	+Vbat power supply
38	Gnd
39	+5V
40	Gnd

### J3 connector to potentiometer

Pin	Description
1	Vref
2	Cursor
3	Gnd

### J4 connector to internal battery

Pin	Description
1	+ battery
2	- battery

### J5 connector to motor

Pin	Description
1	+Vbat
2	+Vbat
3	Phase D
4	Phase C
5	Phase B
6	Phase A
7	Opto rotation anode diode /+5V
8	Opto rotation cathode diode
9	Opto rotation transistor collector
10	GND/ opto rotation transistor emitter

### J6 connector to RS232 and Master plugs

Pin	Description
1	TX1 transmit data
2	+5V
3	RX1 receive data
4	Gnd
5	TDR data terminal ready
6	APP-INF-COM Nurse call relay common point
7	APP-INF-NO Nurse call relay normally open
8	APP-INF-NF Nurse call relay normally closed
9	CD ON external start control
10	CD OFF external stop control
11	I-OPTON motor output control
12	I-SECT mains LED
13	+Vbat external power supply plug
14	RX2 receive data
15	TX2 transmit data
16	Gnd power supply
17	CTS clear to send
18	RTS ready to send
19	BUZ external buzzer control

### J7 connector to external DC power supply

Pin	Description
1	± external power supply
2	± external power supply

### J8 connector to declutching micro-switch, force sensor and anti-siphon switch

Pin	Description
1	+Vref + internal gauge bridge
2	E1 internal gauge bridge input
3	E2 internal gauge bridge input
4	Gnd – internal gauge bridge
5	Opto anti-siphon LED cathode
6	Opto anti-siphon LED anode / +5V
7	Opto anti-siphon transistor collector
8	Disengagement micro-switch on
9	Disengagement micro-switch off
10	Gnd

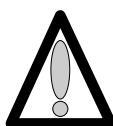

Remember to dismount the ribbon cable holder on the power supply board before extracting the mechanical assembly from the case (the ribbon cable may break).

### J9 connector, test points

Pin	Description
1	GND
2	Position sensor output
3	Battery discharge control output
4	Amplified force sensor output
5	Cd coupler power supply 0-5V
6	Motor control opto output
7	Force and position sensor reference voltage
8	Piston head detection opto output
9	Control/APIN F
10	Control/APIN F

**Note:** Board diagrams are available on request; please contact our After Sales service. Refer to "Useful addresses" on the last page.

#### 2.1.4 Mechanical gear base unit

---

The mechanical base unit is composed of a motor-reducer block driving a screw-and-nut unit. At the shaft end, the motor receives a control panel associated with an opto-electronic switch.

The mechanical base unit also accommodates a potentiometer fitted with a rack pinion system.

#### 2.1.5 Mechanical plunger unit

---

The mechanical plunger unit is mounted onto the mechanical base unit. The latter carries out the long travel guiding and displacement of the plunger by means of the screw-and-nut system.

The plunger is fitted with a disengagement control allowing to separate it from the screw-and-nut system.

## 2.2 Functional description

---

From a functional point of view, the **Pilot Delta** is composed of three sub-assemblies :

- A syringe position control and maintenance sub-assembly.
- A motorisation sub-assembly.
- An external connection sub-assembly.

### 2.2.1 Syringe control and maintenance sub-assembly

---

The syringe is fitted into the upper case and held in position by means of a syringe clamp.

Detection of the syringe size (60 cc or 20 cc) is carried out by two opto-electronic sensors mounted onto the syringe clamp.

The fin switch ensures the syringe fins are correctly positioned in the groove.

Associated with an opto-electronic sensor, the anti-siphon arm controls the piston position.

Composed of a force sensor fitted to the plunger, an anti-occlusion system detects the force exerted on the piston and triggers an alarm whenever this force is excessive.

### 2.2.2 Motorisation sub-assembly

---

This sub-assembly moves the piston in the syringe.

It is put into motion by means of a motor-reducer unit associated with a screw-and-nut system.

A motor rotation disk mounted on the shaft end of the motor and associated with an opto-electronic sensor controls the rotation.

A potentiometer controls the plunger movement by means of a rack pinion system.

A micro-switch allows for control of the disengagement device.

### 2.2.3 External connection sub-assembly

---

The **Pilot Delta** has three connectors located at the rear end of the lower case:

- A 12-15 V DC, 15 W type external power supply connector.
- An RS 232 connector.
- A Master connector for the connection of a Master module (optional).



## 3 Description of the menus

### 3.1 Pressure parameter configuration menu

The configuration menu enables users to adapt the **Pilot** to the specific needs of each department. It provides access to the menus allowing for customisation of the parameters associated with pressure.

**Fresenius Vial** recommends users to implement the selected configuration procedures in the presence of qualified personnel or an employee of the technical department.









*It is possible to exit the configuration mode at any time by pressing the **OFF** key.*

This menu enables users to:

- **P r E S . 1**: memorisation of the pressure limit.
- **P r E S . 2**: memorisation of the maximum pressure.
- **P r E S . 3**: pressure drop detection threshold.

#### 3.1.1 Access to menus

##### Keys used

Key	Function
	<b>ON</b> , is used to switch the machine on. <b>OFF</b> , is used to switch the machine off and, when pressed for over three seconds, to exit the configuration mode.
	<b>SILENCE ALARME</b> , is used to access the configuration mode.
	<b>PRESSURE LIMIT</b> , associated with the "SILENCE ALARME" key, allows to access the pressure configuration mode.
	<b>(SHIFT CURSOR)</b> enables the user to shift the cursor by one digit per set of figures.
	<b>INCREMENTATION and DECREMENTATION</b> enable the user to scroll the numbers and characters on the LCD screen.
	<b>VALIDATION</b> enables the user to validate the test choice or to move from one set of values to another.
	<b>STOP</b> , is used to cancel the current configuration.

### Switching to pressure configuration mode.

- Press the "SILENCE ALARME" and "OPT" keys simultaneously.
- Maintain this position while pressing "ON".
- When **PrES** is shown on the display unit, release the selection of "SILENCE ALARME" and "OPT". Validate within three seconds by pressing "VALIDATION".
- **PrES.1** is displayed by default
- Switching from **PrES.1** to **PrES.4** is carried out using the "INCREMENTATION or DECREMENTATION" keys.

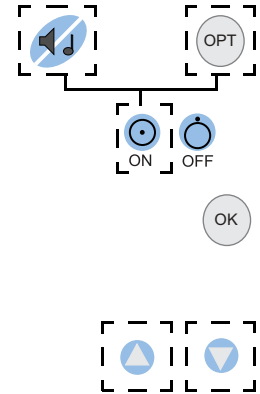

### 3.1.2 PrES.1, memorisation of the pressure limit

This configuration enables the user to memorise the pressure limit given by default each time the device is switched on.

- **PrES.1**, press "VALIDATION" details may be read on the LCD screen.
  - Either **- - -**, the pilot uses the value last programmed before shutdown,
  - Or a value previously memorised by PrES.1.
  - This may be modified each time it is read. SHIFT CURSOR key is used to access the digit in question. The "INCREMENTATION and DECREMENTATION" keys are used to modify the values, and the "VALIDATION" is used to confirm.

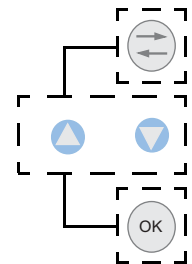
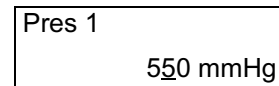

This value may be set between 100 and 900 mmHg by increments of 50.



*The modification can be cancelled by pressing the "STOP" key.*

*It is possible to exit the configuration mode at any time by pressing the "OFF" key.*





### 3.1.3 $P r E 2$ , memorisation of the maximum pressure

This configuration is used to memorise the **maximum** pressure limit of the syringe capacity.

■  $P r E 5.2$ , press "VALIDATION"

details may be read on the LCD screen.

- A value for the 50 cc syringes, e.g. "900 mmHg".
- Press "VALIDATION" again, a value for 20 cc syringes is configured.

Pres 2	
50 cc	900 mmHg

- This value may be modified each time it is read. (SHIFT CURSOR) key is used to access the digit in question. The "INCREMENTATION and DECREMENTATION" keys are used to modify the values, and the "VALIDATION" is used to confirm.

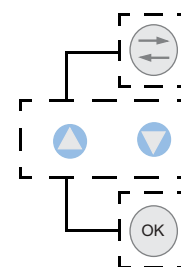

This value may be adjusted for 50 cc syringes between 100 and 900 mmHg by increments of 50 cc.

This value may be adjusted for 20 cc syringes between 100 and 900 mmHg by increments of 50 cc.

This value is the upper limit for  $P r E 5.1$



*The modification can be cancelled by pressing the "STOP" key.*

*It is possible to exit the configuration mode at any time by pressing the "OFF" key.*



### 3.1.4 $P r E 5.3$ , pressure drop detection threshold

This configuration enables the user to memorise the pressure limit below which the "pressure drop" pre-alarm  $P r E 5.3$ , will be triggered during infusion (down arrow +alternating beep).

■  $P r E 5.3$ , press "VALIDATION"

details may be read on the LCD screen.

- Either value 0, if the instrument has not yet been configured.
- Or a previously memorised default value.

Pres 3	
	550 mmHg

- This value may be modified each time it is read. SHIFT CURSOR key is used to access the digit in question. The "INCREMENTATION and DECREMENTATION" keys are used to modify the values, and the "VALIDATION" is used to confirm.

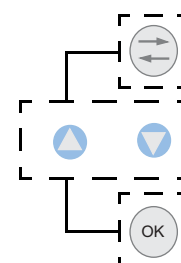

This value may be set between 0 and 900 mmHg by increments of 50.



*The modification can be cancelled by pressing the "STOP" key.*

*It is possible to exit the configuration mode at any time by pressing the "OFF" key.*





## 3.2 Configuration menu of the basic operation parameters

The configuration menu enables users to adapt the **Pilot** to specific needs. It provides access to the menus allowing for customisation of the parameters associated with basic operation modes.

**Fresenius Vial** recommends users to implement the selected configuration procedures in the presence of qualified personnel or an employee of the technical department.









*It is possible to exit the configuration mode at any time by pressing the **OFF** key.*

This menu enables users to:

- **PAR .1**: Select the type of flow rate memorisation.
- **PAR .2**: Select the syringe selection mode.
- **PAR .3**: choose the maximum flow rates which can be selected using the keyboard.
- **PAR .4**: Configure the list of syringes that can be selected.
- **PAR .5**: Select compulsory draining.
- **PAR .6**: select the start-up system.
- **PAR .7**: select the KVO flow rate.
- **PAR .9**: Select the RS232 communication speed.
- **PAR .R**: Select the empty syringe mode.
- **PAR .b**: select the frequency of preventive checks.
- **PAR .C**: select the protocols.
- **PAR .d**: select the fin detection mode.
- **PAR .E**: select the programmed Bolus memorisation mode.
- **PAR .F**: select the Bolus memorisation mode.
- **PAR .G**: select the flow mode.
- **PAR .J**: select the mains disconnection signal.
- **PAR .P**: configure user service.

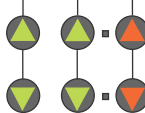
### 3.2.1 Access to menus

#### Keys used

Key	Function
	<b>ON</b> , is used to switch the machine on. <b>OFF</b> , is used to switch the machine off and, when pressed for over three seconds, to exit the configuration mode.
	<b>SILENCE ALARME</b> , is used to access the configuration mode of the current operation parameters.
	<b>The selection keys</b> allow to scroll the numbers and characters on the tens, units, tens segments etc.
	<b>DECALAGE DU CURSEUR (SHIFT CURSOR)</b> enables the user to shift the cursor by one digit per set of figures.
	<b>INCREMENTATION and DECREMENTATION</b> enable the user to scroll the numbers and characters on the LCD screen.
	<b>VALIDATION</b> enables the user to validate the test choice or to move from one set of values to another.
	<b>STOP</b> , is used to cancel the current configuration.

#### Switch to configuration mode.

- Press "SILENCE ALARME" and "DIZAIN" (TENS) simultaneously.
- Maintain this position while pressing "ON".

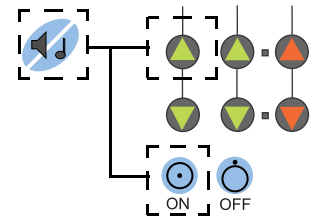

- When  $PAR .$  is displayed on the screen, release "SILENCE ALARM" and "TENS", then validate. Validate within three seconds by pressing "VALIDATION".



- $PAR .$  is displayed by default.

- Switching from  $PAR .$  to  $PAR .$  is carried out using the "tens" selection key.

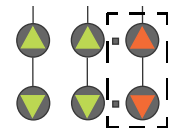

### 3.2.2 *Par 1*, configuration of the flow rate memorisation type

This configuration is used to choose whether or not to memorise the infusion flow rate when the **Pilot** is shut down.

- *Par 1*, press "VALIDATION".
- "Par 1" is displayed on the LCD screen.
  - If there is no "x" in the checkbox, the infusion flow rate is memorised.
  - If an "x" is shown in the checkbox, the infusion flow rate is not memorised.
- The "infusion flow rate or not" choice may be modified by using the "INCREMENTATION" key.
- By validating, the choice is memorised, and the following configuration may be accessed.

Par 1



The modification can be cancelled by pressing the "STOP" key.



### 3.2.3 *Par 2*, configuration of the syringe selection type

This configuration enables users to choose the type of syringe selection out of a choice of 2.

- *Par 2*, press "VALIDATION".
- "Par 2" is displayed on the LCD screen.
  - If "SEL3", automatic validation of the only syringe that may be selected.
  - If "SEL4", when the **Pilot** is switched on, the user should select the type of syringe installed.
- Use the "INCREMENTATION" key to scroll the different selections.
- By validating, the choice is memorised, and the following configuration may be accessed.

Par 2  
SEL3



When mode "SEL3" is selected, and if there is a choice of more than one syringe, the **Pilot** automatically moves onto the configuration of the list of syringes that may be selected *Par 4* when the machine is next switched on.



The modification can be cancelled by pressing the "STOP" key.



### 3.2.4 *Par 3*, maximum flow rate that may be selected on the keyboard.

This configuration enables users to choose the maximum flow rate that may be selected using the keyboard for each type of syringe.

Syringe type	Min. flow rate (ml/hr)	Max. flow rate (ml/hr)
50/60 cc	0.1	1200
20 cc	0.1	600

- *Par 3*, press "VALIDATION".



- "Par 3" is displayed on the LCD screen.

Par 3	
50cc	999.0 ml/hr

- Press "VALIDATION" to select the syringe.



- These values may be modified each time they are read. SHIFT CURSOR key is used to access the digit in question. The "INCREMENTATION and DECREMENTATION" keys are used to modify the values, and the "VALIDATION" is used to confirm.

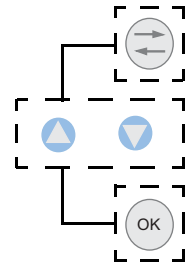

- By validating, the choice is memorised, and the following configuration may be accessed.



*The modification can be cancelled by pressing the "STOP" key.*



### 3.2.5 *Par 4*, configuration of the list of syringes that may be selected

This configuration enables users to choose whether or not it may be selected for each type of active syringe.

- *Par 4*, press "VALIDATION".
- "BD Plastipak" is displayed on the LCD screen.
  - If an "x" is shown in the checkbox, the syringe type is memorised.
  - If there is no "x" in the checkbox, the syringe type is not memorised.
- The "syringe type or not" choice may be modified by using the "INCREMENTATION" key.
- By validating, the choice is memorised, and the following configuration may be accessed.

BD Plastipak	
50cc	<input checked="" type="checkbox"/>



*The modification can be cancelled by pressing the "STOP" key.*



### 3.2.6 *Par 5*, configuration of the compulsory priming

This configuration enables users to choose whether or not draining is compulsory after the syringe is selected.

- *Par 5*, press "VALIDATION".
- "Par 5" is displayed on the LCD screen.
  - If an "x" is shown in the checkbox, the compulsory priming is memorised.
  - If there is no "x" in the checkbox, the compulsory priming is not memorised.

Par 5	
	<input checked="" type="checkbox"/>



- The "compulsory priming or not" choice may be modified by using the "INCREMENTATION" key.
- By validating, the choice is memorised, and the following configuration may be accessed.



The modification can be cancelled by pressing the "STOP" key.

### 3.2.7 Par 6, configuration of the rapid infusion start-up

This configuration enables users to choose whether or not to activate the rapid infusion start-up system.

- **Par 0.6**, press "VALIDATION".
- "Par 6" is displayed on the LCD screen.
  - If an "x" is shown in the checkbox, the rapid infusion start-up is memorised.
  - If there is no "x" in the checkbox, the rapid infusion start-up is not memorised.
- The "rapid infusion start-up or not" choice may be modified by using the "INCREMENTATION" key.
- By validating, the choice is memorised, and the following configuration may be accessed.



Par 6	<input checked="" type="checkbox"/>
-------	-------------------------------------



The modification can be cancelled by pressing the "STOP" key.

### 3.2.8 Par 7, configuration of the KVO flow rate

This configuration allows for the selection of the KVO flow rate.

- **Par 0.7**, press "VALIDATION".
  - 2 KVO values are displayed on the LCD screen.



KVO =	1.0ml/h
KVO =	2.0 ml/h

- These values may be modified each time they are read. SHIFT CURSOR key is used to access the digit in question. The "INCREMENTATION and DECREMENTATION" keys are used to modify the values, and the "VALIDATION" key is used to confirm.

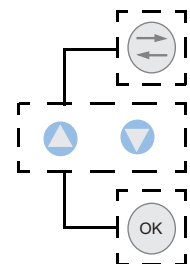

The modification can be cancelled by pressing the "STOP" key.

### 3.2.9 Par 9, configuration of the RS232 communication speed

This configuration enables the user to select the communication speed of the RS232 link.

- **Par 9**, press "VALIDATION".
- "Par 9" is displayed on the LCD screen with the last value memorised.
  - These values may be modified each time they are read. The "INCREMENTATION and DECREMENTATION" keys are used to modify the values, and the "VALIDATION" key is used for validation.
    - 4,800 Bauds.
    - 9,600 Bauds.
    - 19,200 Bauds.

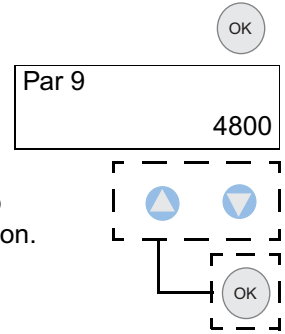

The modification can be cancelled by pressing the "STOP" key.



### 3.2.10 Par A, configuration of the empty syringe mode

This configuration enables users to select a type of operation for the instrument using the empty syringe mode.

- **Par A**, press "VALIDATION".
- "Par A" is displayed on the LCD screen.
  - If an "x" is shown in the checkbox, use of the empty syringe mode is memorised.
  - If there is no "x" in the checkbox, use of the empty syringe mode is not memorised.
- The "use of empty syringe mode or not" choice may be modified by using the "INCREMENTATION" key.
- By validating, the choice is memorised, and the following configuration may be accessed.

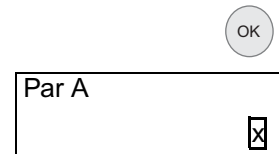

The modification can be cancelled by pressing the "STOP" key.





### 3.2.11 $PAR.b$ , configuration of the frequency of preventive checks

This configuration enables users to select the maintenance periodicity (between 1 and 9999 hours) and the date for the next maintenance.

- $PAR.b$ , press "VALIDATION".
- The current values are displayed on the LCD screen.

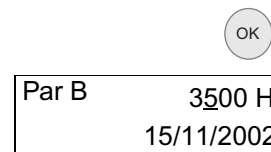

- These values may be modified each time they are read. SHIFT CURSOR key is used to access the digit in question. The "INCREMENTATION and DECREMENTATION" keys are used to modify the values, and the "VALIDATION" key is used for data validation.
- After the last validation, the next configuration can be accessed.

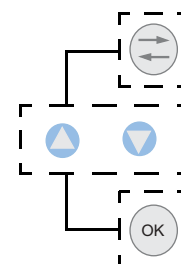

The modification can be cancelled by pressing the "STOP" key.



### 3.2.12 $PAR.C$ , configuration of the protocols memorised

This configuration enables users to choose and parameterise the drugs used.

- $PAR.C$ , press "VALIDATION" details may be read on the LCD screen.
- A list of products with their arbitrary quantities that can be scrolled through, by successive validation.
  - If an "x" is shown in the checkbox, the product is memorised.
  - If there is no "x" in the checkbox, the product is not memorised.
- Use the "INCREMENTATION" key to activate/desactivate the product
- By validating, the choice is memorised, and the next configuration may be accessed.



The modification may be cancelled by pressing the "STOP" key.

### 3.2.13 Par D, configuration of the fin detection mode

This configuration enables users to choose whether or not to activate the fin position contact.

- **Par D**, press "VALIDATION"
- "Par D" is displayed on the LCD screen.
  - If an "x" is shown in the checkbox, use of the correct fin position mode is memorised.
  - If there is no "x" in the checkbox, use of the correct fin position mode is not memorised.
- The "use of correct fin position mode or not" choice may be modified by using the "INCREMENTATION" key.
- By validating, the choice is memorised, and the next configuration may be accessed.

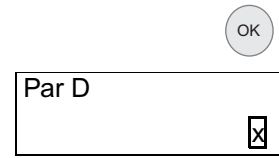

The modification can be cancelled by pressing the "STOP" key.

### 3.2.14 Par E, configuration of the flow rate memorisation mode programmed bolus

When the equipment is shut-down, this configuration enables users to choose whether or not to activate the last programmed bolus flow rate.

- **Par E**, press "VALIDATION"
- "Par E" is displayed on the LCD screen.
  - If an "x" is shown in the checkbox, use of the last programmed bolus flow rate mode is memorised.
  - If there is no "x" in the checkbox, use of the last programmed bolus flow rate is not memorised.
- The "INCREMENTATION" key enables the user to activate/desactivate the bolus flow rate that was last programmed.
- When this mode is not active, pressing the "VALIDATION" key allows to select the bolus flow rate according to the syringe capacity.

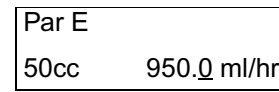
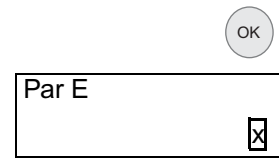

□ These values may be modified each time they are read. SHIFT CURSOR key is used to access the digit in question. The "INCREMENTATION" and "DECREMENTATION" keys are used to modify the values, and the "VALIDATION" key is used to confirm.

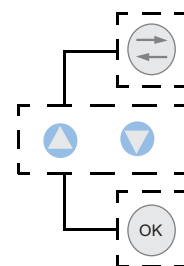

- By validating, the choice is memorised, and the next configuration may be accessed.



The modification can be cancelled by pressing the "STOP" key.

### 3.2.15 $PR_r .F$ , configuration of the bolus flow memorisation mode

This configuration enables users to select the simple bolus flow memorisation mode.

- $PR_r .F$ , press "VALIDATION"
- "Par F" is displayed on the LCD screen.
  - If an "x" is shown in the checkbox, the simple bolus flow rate value is used by default.
  - If no "x" is shown in the checkbox, the simple bolus flow rate value needs to be programmed.
- Press "VALIDATION" again to select the value according to the syringe capacity.

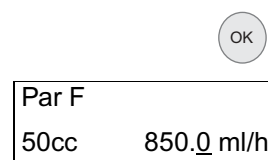
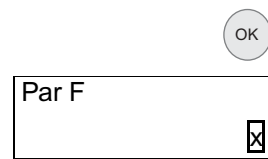

- The "use of simple bolus mode or not" choice may be modified by using the "INCREMENTATION" key.

□ These values may be modified each time they are read. SHIFT CURSOR key is used to access the digit in question. The "INCREMENTATION and DECREMENTATION" keys are used to modify the values, and the "VALIDATION" key is used to confirm.

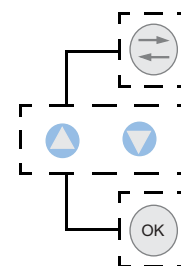

- By validating, the choice is memorised, and the next configuration may be accessed.



*The modification can be cancelled by pressing the "STOP" key.*



### 3.2.16 $PR_r .G$ , configuration of the flow rate mode

This configuration allows for the selection of the flow rate type.

- $PR_r .G$ , press "VALIDATION"
- If an "x" is shown in the checkbox, the flow rate mode is memorised.
- If there is no "x" in the checkbox, the simple bolus mode is not memorised.
- The "use of mode or not" choice may be modified by using the "INCREMENTATION" key.
- Press "VALIDATION" again to switch to the next mode.

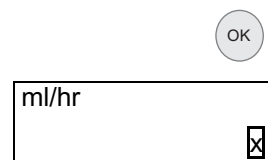

*The modification can be cancelled by pressing the "STOP" key.*



### 3.2.17 *Par J*, configuration of the mains disconnection signal

This configuration enables users to choose whether or not to activate the power cut detection beep.

- *Par J*, press "VALIDATION"
- "Par J" is displayed on the LCD screen.
  - If an "x" is shown in the checkbox, use of the mains cut detection signal mode is not memorised.
  - If there is no "x" in the checkbox, use of the mains cut detection signal mode is memorised.

- The "use of mains cut detection signal mode or not" choice may be modified by using the "INCREMENTATION" key.
- By validating, the choice is memorised, and the next configuration may be accessed.



*The modification can be cancelled by pressing the "STOP" key.*

### 3.2.18 *Par p*, configuration of the user service name

This configuration allows to specify the user service.

*Par p*, press "VALIDATION"

- "Par p" is displayed on the LCD screen.
- 15 characters are available for input.

- SHIFT CURSOR key is used to access the digit in question. The "INCREMENTATION and DECREMENTATION" keys are used to modify the characters or values.

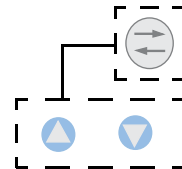

- By validating, the choice is memorised, and the next configuration may be accessed.



*The modification can be cancelled by pressing the "STOP" key.*

## 3.3 Calibration menu

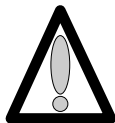

The calibration menu is reserved for authorised personnel only, its access is protected by a secret code.  
To determine the operation mode of the different calibrations, refer to the “Calibrations” chapter

This menu allows for calibration:

- **E t R 4**: of the three levels of battery voltage alarms.
- **E t R 6**: of the position potentiometer.
- **E t R 9**: of the force sensor.



### 3.4 ASS test menu

The ASS test menu is reserved for authorised personnel only. It enables users to perform a series of **Pilot** inspections to validate its operation (see “**Checks**” chapter). This must be carried out each time parts are replaced.



*The ASS tests may also be performed more easily and more quickly using a PC with installed maintenance software (consult our After Sales Service).*

The ASS test menu enables users to perform a series of 16 tests or checks:

- **t S t 1**: Displays the running time and the maintenance date.
- **t S t 2**: Indicator lights test.
- **t S t 3**: Keyboard test.
- **t S t 4**: Displays the battery voltage.
- **t S t 5**: Displays the codes of the last 10 alarms.
- **t S t 6**: Displays the total running time.
- **t S t 7**: TTL serial link test.
- **t S t 8**: RS 232 serial link test.
- **t S t 9**: Displays the piston force.
- **t S t A**: Displays the software version.
- **t S t b**: Displays the analogue input.
- **t S t C**: Displays the plunger position.
- **t S t E**: Displays the calibration values.
- **t S t F**: Displays the syringe type.
- **t S t J**: Displays the last 10 events before the last fatal error.
- **t S t L**: Agents library.





## 4 Preventive maintenance

### 4.1 Recommendations

The **Pilot** syringe pump can only be inspected, serviced or repaired by **Fresenius Vial** or by an authorised and appointed service. The qualified technicians in your establishment and our After Sales Service should be notified of any abnormal operation of the device.

If a repair is necessary, send the instrument in its original packaging if possible with a precise description of the observed fault, to the official dealer for **Fresenius Vial**.

For further information concerning troubleshooting or the usage procedure, please contact our After Sales Service or our Sales Department.

**Fresenius Vial** is not liable for loss or damage to the equipment during transport to our After Sales Service.

### 4.2 Maintenance schedule

#### 4.2.1 Use beyond the framework of the departmental order

Frequency	Name
12 months	Carry out a servicing inspection.
3 years	Replace the battery (see "Battery-holder and battery" operation sheet).

#### 4.2.2 Use within the framework of the departmental order

When the equipment is used within the framework of the departmental order of October 3 1995, inspections are performed on a less frequent basis. This is due to the fact that the equipment is inspected before each use.

Frequency	Name
1 <sup>st</sup> inspection in the 3 <sup>rd</sup> year	Perform the first servicing inspection.
Then every 2 years	Perform a servicing inspection.
3 years	Replace the battery (see "Battery-holder and battery" operation sheet).



## 4.3 Checks



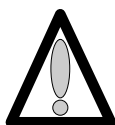



In order to perform equipment follow-up by means of preventive maintenance, a regular servicing inspection is recommended every 12 months (see "Regular servicing sheet").



To ensure the check procedure is carried out efficiently, recharge the battery beforehand (16 hours).

### 4.3.1 Test access

Keyboard description.

Key	Function
 ON OFF	<b>ON</b> , is used to switch the machine on. <b>OFF</b> , is used to switch the machine off and, when pressed for over three seconds, to exit the configuration mode.
	<b>SILENCE ALARME</b> , is used to access the configuration mode of the current operation parameters.
	<b>The selection keys</b> allow to scroll the figures and characters on the tens, units, tens segments etc.
	<b>DECALAGE DU CURSEUR (SHIFT CURSOR)</b> enables the user to shift the cursor by one digit per set of figures.
	<b>INCREMENTATION and DECREMENTATION</b> enable the user to scroll the numbers and characters on the LCD screen.
	<b>VALIDATION</b> enables the user to validate the test choice or to move from one set of values to another.
	<b>STOP</b> , is used to cancel the current configuration.

Activate the ASS test.

- Press the "SILENCE ALARME" and "DECREMENTATION" keys simultaneously.
- Maintain this position while pressing "ON".
- When *t E S t .* is displayed on the screen, release selection of the "SILENCE ALARME" and "DECREMENTATION" keys, then validate within three seconds by pressing the "CONFIRM" key.
- By default, the equipment starts with test n°1 *t E S t . 1*
- Switching from *t E S t . 1* to *t E S t . L* is carried out using the "tens" keys.

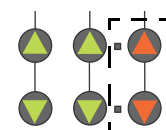
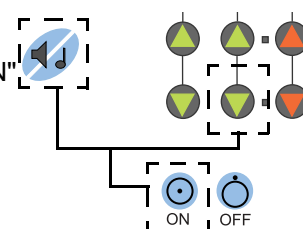

### 4.3.2 Visual check

Check the general appearance of the case and labels, and check for any traces of shock.

### 4.3.3 Running time and servicing inspection date

This test allows for display of the **Pilot** running time since its last servicing inspection. It also allows for display and modification of the "last" servicing inspection date. When the servicing inspection date is modified, the running time is reset.

- **EESE.1**, press the "VALIDATION" key.

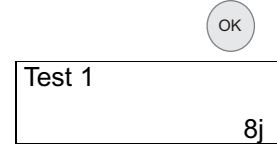

Details may be read on the LCD screen,

- The maximum number of hours of use.
- The maximum number of days of use.
- The number of months, (average duration of one month considered as 30 days).

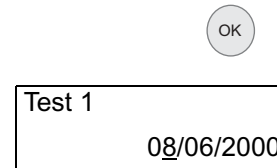

- Press "VALIDATION" again to display the date of the last servicing inspection showing the day, month and year.



- Press  or  to display the date and the last maintenance date.
- Display the date and press "VALIDATION" to take the new maintenance date into account.
- By pressing "VALIDATION" once again, a different test may be selected.



*The test may be stopped at any time by pressing the "STOP" key, and a different test may be selected.*



### 4.3.4 Indicator lights check

This test checks the efficiency of the indicator lamps, the display units and the front panel LCD screen.

- **EESE.2**, press the "VALIDATION" key.

- All LEDs, 7-segment display units and LCD screen are ON.
- Press "VALIDATION" again.
  - ♦ The LEDs and display units are scrolled one by one from left to right. (display of the LEDs, 8-segment display unit by segment and then by sets of 8, LCD display unit with 40 characters over 2 lines per set of 5 as well as the symbols).
  - ♦ A beep is heard when the action is over.



The text is OK if all indicator lamps are lit up.



*The test may be stopped at any time by pressing the "STOP" key, and a different test may be selected.*













### 4.3.5 Keyboard check

This test allows to check that all keyboard keys function correctly.

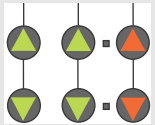
- **⌘ ⌘ ⌘ ⌘ . ⌘**, press the "VALIDATION" key.
  - Keep each key pressed down, one by one,
    - ♦ Check the name of the key displayed on the LCD screen.



The name of each key is displayed as follows:

Selected key	Display on the LCD screen
 OFF	OFF
 SIAL	SIAL
 STOP	STOP
 START	START
 BOLUS	BOLU
	INC+++, INC++, INC+ DEC+++, DEC++, DEC+
 OPT	OPT
 DECAL	DECAL
 INC	INC
 DEC	DEC
 OK	OK



If two or more keys are pressed simultaneously, the display unit shows Err and three beeps are heard, indicating an error.  
The "ON" key is not included in the keyboard check.



The test may be stopped at any time by pressing the "VALIDATION" key for over 3 seconds. Another test can then be selected.



If the display is faulty, replace the display board (see "Display and CPU boards").

### 4.3.6 Checking the battery voltage

This test enables users to display the battery voltage in Volts and tenths of a Volt.

- **EESE.4**, press the "VALIDATION" key.

Details may be read on the LCD screen.

- The voltage is displayed in Volts. Mention of the letter "B" means the value refers to the battery, and this should be > 5.7 V.



- By validating once again, a different test may be selected.



### 4.3.7 Testing the last 10 alarms

This test enables users to display the last ten **Pilot** alarms, errors, and shut-down procedures in the form of codes.

- **EESE.5**, press the "VALIDATION" key.

Details may be read on the LCD screen.

- The most recent alarm code is displayed.
  - ♦ "A" for an alarm.
  - ♦ "E" for an error.

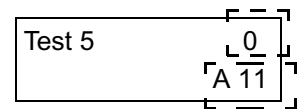

- Press the keys to display the following codes from 0 to 9.



- By validating once again, a different test may be selected.



#### Meaning of the codes:

Alarm	Description	Error	Description
A10	Battery alarm	E01	Rotation control error.
A11	Syringe clamp alarm	E03	Communication.
A12	End of infusion alarm	E14	Error on: verification of syringe parameter consistency (inconsistency of the syringe diameter in relation to the motor pitch for 0.1 ml calculated at the time of syringe validation).
A13	Volume limit alarm	E16/E55	Time dater.
A14	Disengagement alarm	E18	Injected volume reached (1.7 l).
A15	Piston head alarm	E24/E34/ E44/E56	Software error.
A16	Occlusion alarm	E28	Language file error.
A25	Fin alarm	E32	Error on: segment advance control
A26	Mains disconnect	E44	CPU/UART frequency control error
		E50	ADC access self-test error.
		E52	Error on: advance during compensation for play.
		E60	Error on: verification of syringe parameter consistency (inconsistency of the syringe diameter in relation to the motor pitch for 0.1 ml calculated at the time of syringe validation).
		E66	LCD screen error
		E70	Error on: motor frequency fault (motor pitch period calculated in relation to the syringe diameter and the flow rate selected, either too low or too high).
		E72	Error on: advance over the whole length.

Alarm	Description	Error	Description
		E80	Error concerning keypad fault or high electromagnetic interference.
		E82	Displacement control error

- Errors 10, 20, 30 and 40 cannot be stored in EEPROM.
- If the pilot switches off normally, the **OFF** message is displayed.
- If the Pilot switches off normally, the **OFF** message is displayed on the LCD screen with a flashing "F".

#### 4.3.8 Total running time check

This test enables users to display the total running time of the **Pilot**. It is not possible to modify this time manually.

- **t E S t . 6**, press "VALIDATION".

- The number of hours of use.
- The number of days of use.
- The number of months (average duration of one month considered as 30 days).

Test 6  
28 H

OK

- By validating once again, a different test may be selected.

OK

#### 4.3.9 TTL serial link test

This test enables users to check the efficiency of the TTL (80C32) serial link.

To perform this test, use a plug on which lines Rx and Tx are short-circuited (pins 10 and 2).

- **t S t . 7**, press "VALIDATION".

- "LT" is displayed on the LCD screen at the start of the test.
  - ♦ If "LTOK" is displayed, the test is successful.
  - ♦ If "LTER" is displayed, the test is unsuccessful.

Test 7  
LTOK

OK

- By validating once again, a different test may be selected.

OK

#### 4.3.10 RS 232 serial link check

This test enables users to check the efficiency of the RS 232 (2691) serial link.

To perform this test, use a plug on which lines Rx and Tx, RTS, CTS, DSR and +5V are short-circuited [2 and 3], [7 and 8], [4 and 6].

- **t E S t . 8**, press "VALIDATION".

- If "LROK" is displayed on the LCD screen, the RS 232 link is correct.
- If "LROK" is displayed on the LCD screen, the RTS and CTS link is broken.
- IF "NORC" is displayed on the LCD screen,
  - ♦ the RTS and CTS link is broken.
  - ♦ the DSR and +5 V link is broken.
  - ♦ no plug.

Test 8  
LROK

OK

- By validating once again, a different test may be selected.

OK

It is impossible to carry out this test when the PC is in communication with the Pilot. In this case, "OPEN" is displayed.

### 4.3.11 Checking the force sensor

This test enables users to display the force exerted on the piston.

■ **тест.9**, press "VALIDATION". OK

Details may be read on the LCD screen.

- Displayed in grams, the result must lie between 0 and 100 g.

Test 9	0g
--------	----

- Press and release the bonding pad.
  - ♦ The result displayed must always be between 0 and 100 g.

- By validating once again, a different test may be selected. OK

If the value is out of limits, recalibrate the force sensor (see " Force sensor calibration.").

### 4.3.12 Checking the software version.

Run this test to display the software version and revision numbers.

■ **тест.А**, press "VALIDATION". OK

Details may be read on the LCD screen.

- The software revision and version number as well as the check sum and software creation data are displayed.

Test A	V01.32
(B942)	05/07/2000

- By pressing "VALIDATION" once again, the language selected is displayed on a second screen.

Test A	French
(V01.0)	06/07/2000

- By validating once again, a different test may be selected. OK

### 4.3.13 Checking the ADC

Run this test to read the result of the conversion of the five analogue inputs and three test inputs of the converter.

■ **тест.б**, press "VALIDATION". OK

Details may be read on the LCD screen.

- The result displayed is the first of the five analogue inputs (from 0 to 4).

Test B	0
	31D

- The second type of result displayed corresponds to the converter test according to the channel number (L, M, H) Use the "INCREMENTATION and DECREMENTATION" selection keys to move from one input to another.





The analogue inputs are distributed as follows:

Channel number	Part concerned
0	battery voltage
1	n.u.
2	force sensor
3	n.u.
4	displacement potentiometer
L	converter test 0 between 000 and 004 if correct
M	converter mid-scale test between 01FB and 204 if correct
H	converter full-scale test between 03FB and 3FF if correct

- By validating once again, a different test may be selected.



If the value is out of limits, recalibrate the force sensor (see "E t R.9 Force sensor calibration").

#### 4.3.14 Checking the position sensor

This test enables users to display the plunger position in mm and ten<sup>ths</sup> of a mm.

- **t E S t . C**, using the spacers ref. T300775-B or T300940E and T300775G,

- Position the spacer ref. T300940E and press "VALIDATION".
  - ♦ in high position the LCD screen shows 115.0 ± 0.5 mm.

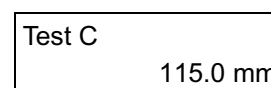

- Position the spacer ref. T300940E and press "VALIDATION".
  - ♦ in low position the LCD screen shows 20.0 ± 0,2 mm.

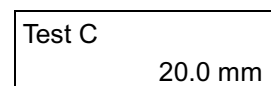

- By validating once again, a different test may be selected.



If the value is out of limits, recalibrate the position sensor (see "E t R.5 Position sensor calibration").

#### 4.3.15 Displaying the calibration values

Run this test to display the calibration values stored in the EEPROM.

- **t S t . E**, press the "VALIDATION" key.



- BAT1 is displayed on the LCD screen alternately with its calibration value.

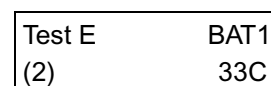

- Press the "INCREMENTATION or DECREMENTATION" key to move onto another value.



**Calibration value according to the codes.**

Display	Name
BAT1	Alarm and pre-alarm battery voltage 6.3 V
BAT2	Pre-alarm battery voltage 5.9 V
BAT3	Alarm battery voltage 5.7 V
HIG.H	Displacement potentiometer with large 115.0 mm spacer
LOW	Displacement potentiometer with small 20.0 mm spacer
0.g	Force sensor with 0.00 kg
5 Kg	Force sensor with 5 kg

**4.3.16 Checking the syringe clamp**

This test displays the type of syringe fitted to the **Pilot**.

- **t 5 t . F**, press the "VALIDATION" key

Using a 50 cc and 20 cc capacity syringe or a spacer, ref. T301521.



- Place the syringe clamp in the higher position.

The LCD screen shows \_ \_ \_

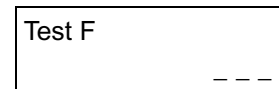

- Position the 50 cc syringe or the spacer, ref. T301521.

The LCD screen displays 50cc.

- Position the 20 cc syringe or the spacer, ref. T301521.

The LCD screen shows **20cc**

- Place the syringe clamp in the lower position.

The LCD screen shows \_ \_ \_



*Capacities which are non-existent or non-configured in the EEPROM are displayed in the form of \_ \_ \_.*

- By validating once again, a different test may be selected.



**4.3.17 Checking the last 10 events before cut-off**

This test enables users to display the last 10 events regarding **Pilot** operation, using the last fatal error.

- **t 5 t . J**, press "VALIDATION".



- The last fatal error code is displayed on the LCD screen.

- ♦ "A" for an alarm. (see Table **t 5 t . 5**)

- ♦ "E" for an error. (see Table **t 5 t . 5**)

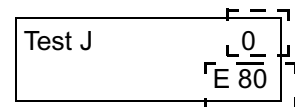

- Press the "INCREMENTATION" key to display the following codes from 0 to 9.



- By validating once again, a different test may be selected.



### 4.3.18 Checking the library

This test enables users to display the list of syringes programmed in the Pilot.

- **5 5 5 .L**, press "VALIDATION".

- The name of the author and the date of the library of protocols stored in the Pilot are displayed on the LCD screen.

Fresenius Vial  
102202 13/11/2000



- By validating once again, a different test may be selected.



### 4.3.19 Checking the disengagement

To carry out this operation, exit the test mode, press "OFF".

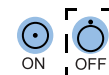

- Press "ON".
  - Lift the disengagement lever.
    - ♦ Check the mechanical disengagement alarm (red LED at the end of the syringe diagram).
  - Fit the 50 cc syringe onto the equipment, ensuring the fin and plunger are in position.
  - Release the disengagement lever.
    - ♦ Check that there is no mechanical lever release alarm.
    - ♦ Check that the plunger is locked.

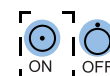

### 4.3.20 Checking the fin detection system

To carry out this operation, exit the test mode, press "OFF".

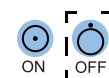

- Press "ON".
  - Fit the 50 cc syringe onto the equipment, ensuring the plunger and clamp are in position.
  - On the LCD screen, ensure the syringe is detected appropriately, eg. "50cc".
  - Place the syringe on the equipment, ensuring the fin is out of the groove.
  - Fit the syringe clamp and plunger correctly.
  - Make sure the light alarm flashes, locating the problems on the syringe diagram.

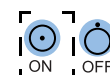

### 4.3.21 Checking the anti-siphon arm



*This check must be carried out for every syringe provided with the equipment.*

- Check the functionality.
  - Free travel, with no shaft play, and no dismounting of the latter.
- Check for alarm presence with.
  - Anti-siphon arm in the upper position.
  - Anti-siphon arm in the lower position.

Ensure there is no alarm in presence of spacers or 20 cc and 50 cc syringes.

- Using spacers ref. T301518-A and T301519-B.
  - To carry out this operation, exit the test mode and press "OFF",
  - Press "ON".
  - Fit the instrument with the spacer ref T301518-B and lock it into position using the syringe clamp.
    - ◆ Place the syringe plunger against the spacer with the syringe head detection arm on the spacer.
    - ◆ "20cc" is displayed on the LCD screen without triggering the alarm.
  - Fit the instrument with the spacer ref T301519-C and lock it into position using the syringe clamp.
    - ◆ Place the syringe plunger against the spacer with the syringe head detection arm on the spacer.
    - ◆ "50cc" is displayed on the LCD screen without triggering the alarm.

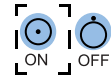
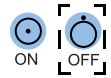

- Using 20cc and 50cc syringes.
  - To carry out this operation, exit the test mode and press "OFF",
  - Press "ON".
  - Fit the instrument with the 20 cc syringe and lock it into position using the syringe clamp.
    - ◆ Place the syringe plunger against the syringe with the syringe head detection arm on the syringe piston.
    - ◆ "20cc" is displayed on the LCD screen without triggering the alarm.
  - Fit the instrument with the 50 cc syringe and lock it into position using the syringe clamp.
    - ◆ Place the syringe plunger against the syringe with the syringe head detection arm on the syringe piston.
    - ◆ "50cc" is displayed on the LCD screen without triggering the alarm.

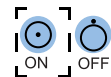
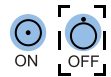

### 4.3.22 Checking backpressure

To carry out this operation, exit the test mode, press "OFF",

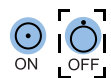

*The instrument initialises the sensor once the plunger is disengaged.  
The backpressure test must be performed with zero backpressure.*

- Press "ON".
  - Position the 50 cc BD Plastipack syringe on the equipment and lock it into position using the clamp, ensuring the fin and plunger are positioned correctly.
  - Place the manometer (or any other pressure measurement equipment) at the syringe outlet.
  - Select a 50 ml "B-D PLASTIPAK" syringe by pressing "VALIDATION".
  - By pressing the "OPT" key, select a medium limit:
    - ◆ M (medium limit) = 500 mmHg  $\pm$  75 or 0.65 bar  $\pm$  0.1 bar.

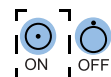

- Select a maximum flow rate and initiate the infusion by pressing the "VALIDATION" key.
  - ♦ Ensure there is no acoustic and visual alarm (backpressure indicator off).
  - ♦ Check that the infusion LEDs are flashing.
  - ♦ Ensure the alarm is triggered for a value of 500 mmHg  $\pm$  75 or 0.65 bar  $\pm$  0.1 bar.
- Repeat this test selecting a higher limit by pressing the LIMIT PRESSURE key.
  - ♦ M (medium limit) = 900 mmHg  $\pm$  150 or 1.2 bar  $\pm$ 0.2 bar.



If the value is out of limits, recalibrate the force sensor (see "Ét R.9 Force sensor calibration").

Before calibrating the force sensor, check the voltage between point J09.1 (ground) and J09.4, using an oscilloscope. Voltage value = 0.6V  $\pm$  0.05V (square signal).

### 4.3.23 Checking the end of infusion pre-alarm

To carry out this operation, exit the test mode, press "OFF",

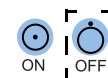

- Press "ON".
  - Fit the syringe on the equipment, ensuring the fin and plunger are in position.
  - On the LCD screen, ensure the syringe is detected appropriately, eg. "50cc".
  - Select a "B-D PLASTIPAK" syringe filled to 20 ml.
  - Select a flow rate of 120 ml/hr.
    - ♦ For normal flow rates, the pre-alarm is activated 5 minutes before end of infusion.
    - ♦ Flow rate example: > 60 ml/hr, the pre-alarm is activated when the remaining volume equals 10% of the total syringe capacity.
    - ♦ Ensure the end of infusion pre-alarm is present.
  - Press the "SILENCE ALARME".
    - ♦ The acoustic alarm is silenced and the visual signal is maintained.
  - Measure the "hard height" at "end of infusion".
    - ♦  $18,5 \leq x \leq 19.5$ .

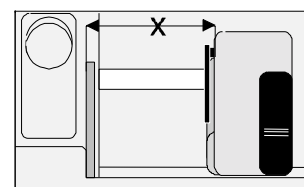
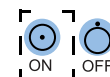

Top view



For accurate checking of the "hard height", do not move the plunger when measuring.

If the "hard height" reading is out of limits, recalibrate the position sensor (voir "Ét R.5 Position sensor calibration.").

### 4.3.24 Checking the linearity

To carry out this operation, exit the test mode, press "OFF",

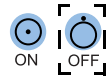

- Tools required: Chronometer, calliper square, BD Plastipak 50 ml. syringe.

- Press "ON".

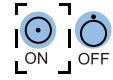

- Fit the equipment with the "B-D PLASTIPAK" 50 ml syringe, ensuring the fin and plunger are in starting position.
- Measure the distance X in mm.

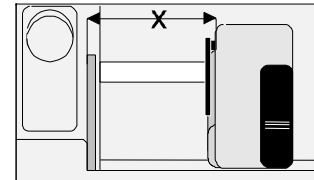

Top view

- On the LCD screen, ensure the syringe is detected appropriately, eg. "50cc".
- Select a "B-D PLASTIPAK" syringe filled to 50 ml.
- Select a flow rate of 50 ml/hr.
- Press "VALIDATION" to start infusion and simultaneously start the chronometer
- After 50 minutes, stop the infusion by pressing "STOP" and measure the X2 range.
- Ensure  $X = X_1 - X_2$  lies between  $74.96 \text{ mm} \leq X \leq 76.47 \text{ mm}$ .



*For a more accurate linearity check, do not move the plunger when measuring.*

### 4.3.25 Checking mains/battery operation

To carry out this operation, exit the test mode, press "OFF",



- Connect the equipment to a mains supply.
  - Check the operation of the mains presence LED (indicator in the shape of a plug).
- Connect the equipment to a stable power supply.
  - Disconnect the equipment from the mains.
  - Remove the battery holder.
  - Remove the battery.
  - Remove the connection lugs.

- Connect the battery lugs to a stabilised supply set at 6.3 V. Respect the polarities.
- Press "ON".
- Select a syringe from the syringe list proposed by the equipment.

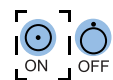

- Press "VALIDATION"



- Select a flow rate and validate.
- Reduce the stable power supply voltage until the battery discharge pre-alarm is triggered.
  - ◆ Ensure it is triggered between 5.8 V and 6 V.



*The acoustic alarm can be temporarily silenced by pressing "SILENCE ALARME" (2 minutes).*



- Reduce the test power supply voltage again until the battery discharge alarm is triggered.
  - ◆ Ensure this is triggered between 5.6 V and 5.8 V.

If the results obtained during the tests differ from the values indicated, recalibrate the battery voltage levels (see "E 4.4 Calibration of the 3 battery voltage levels.").

#### 4.3.26 Battery autonomy test

- Recharge the battery for at least 16 hours (100% of its capacity).
- Run a battery life test greater than one hour.
  - Select a flow rate of 120 ml/h for a 50 ml/h B-D Plastipak syringe (no connections to Master module), then validate.
  - The "battery discharge" pre-alarm informs the user on the remaining time, between 60 minutes to 5 ml/h.
    - ◆ The "total battery discharge" will sound before the infusion is stopped.

#### 4.3.27 Continuity test

Using a multimeter.

To carry out this operation, exit the test mode, press "OFF",

- Connect the multimeter to an ohmmeter.
  - Check the electrical resistance shown by the ohmmeter is over 10 MΩ:
    - ◆ between phase and metal tube.
    - ◆ between neutral and metal tube.

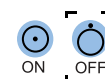





### 4.3.28 Regular inspection sheet

Use this table to note the results of the different tests.

Equipment type:	Code:	Equipment series N°:
-----------------	-------	----------------------

N°	Procedure	Resulting value	Conformity	
			Yes	No
1	■ Check the general condition of the case and its labels.			
2	■ Display total running time, <b>t E S t 1</b> (in hours, days or months):***** .....			
3	■ Display the last servicing inspection date, <b>t E S t 1</b> (in days, months or years):***** .....			
4	■ Check all indicator lights, <b>t E S t 2</b> .			
5	■ Check the keyboard, <b>t E S t 3</b> .			
6	■ Display the total running time, <b>t E S t 6</b> (in hours, days or months):***** .....			
7	■ Check the force sensor, <b>t E S t 9</b> : <input type="checkbox"/> On standby, check that the displayed value is 000.g ± 100 g: ..... <input type="checkbox"/> Press and release the bonding pad, the value displayed should be 000.g ± 100 g: ***** .....			
8	■ Check the ADC, <b>t E S t .b</b> : <input type="checkbox"/> Ensure the value of input 2 is: $066 \leq X \leq 08F$ : ***** .....			
9	■ Check the position sensor, <b>t E S t .c</b> : <input type="checkbox"/> High position with T300940E spacer, check that the displayed value is $115.0 \pm 0.5$ mm: ***** .....			
	<input type="checkbox"/> Low position with T300775G spacer, check that the displayed value is $20.0 \pm 0.5$ mm: ***** .....			
10	■ Check the syringe clamp, <b>t E S t .f</b> . <input type="checkbox"/> Syringe clamp in high position, check that the displayed value is - - - . - :***** .....			
	<input type="checkbox"/> Fit the device with a 50 cc syringe or a T301521 spacer, check that the value displayed is 50cc: ***** .....			
	<input type="checkbox"/> Fit the device with a 20 cc syringe or a T301521 spacer, check that the value displayed is 20cc: ***** .....			
	<input type="checkbox"/> Syringe clamp in low position, check that the displayed value is - - - . - :***** .....			
11	■ Check the anti-siphon arm: <input type="checkbox"/> Free travel without end play. <input type="checkbox"/> Presence of the alarm in high and low position. <input type="checkbox"/> No alarm in presence of min. and max. spacers (T301518) (T301519).			

N°	Procedure	Resulting value	Conformity	
			Yes	No
12	<ul style="list-style-type: none"> <li>■ Check the backpressure (use a <b>Fresenius Vial</b> dynamometer):               <ul style="list-style-type: none"> <li><input type="checkbox"/> Set the flow rate to 120 ml/hr, with induction OFF (pressure limit to 500 mmHg).</li> <li><input type="checkbox"/> Start the infusion</li> <li><input type="checkbox"/> Check the occlusion alarm is triggered at 500 +/- 75 mmHg (0.65 +/- 0,1 bar) of infusion: ***** .....</li> </ul> </li> </ul>			
13	<ul style="list-style-type: none"> <li>■ Check the end of infusion pre-alarm:               <ul style="list-style-type: none"> <li><input type="checkbox"/> Eg.: for a flow rate of 50 ml/hr with a 50 cc BD, check that the pre-alarm is triggered at 5 mn ± 10 s before the end of infusion: ***** .....</li> </ul> </li> </ul>			
14	<ul style="list-style-type: none"> <li>■ Check the end of infusion alarm:               <ul style="list-style-type: none"> <li><input type="checkbox"/> With a 60 cc BD, check that the hard height range is <math>18.5 \leq x \text{ mm} \leq 19.5</math>: ***** .....</li> </ul> </li> </ul>			
15	<ul style="list-style-type: none"> <li>■ Check the linearity (60 cc BD Plastipack):               <ul style="list-style-type: none"> <li><input type="checkbox"/> Measure the plunger starting position range, X1 mm:***** .....</li> <li><input type="checkbox"/> Measure the plunger range after 50 mn pump running, X2 mm: .....</li> <li><input type="checkbox"/> Check: <math>74.96 \leq X1-X2 \text{ mm} \leq 76.47</math>: ***** .....</li> </ul> </li> </ul>			
16	<ul style="list-style-type: none"> <li>■ Check the battery autonomy:               <ul style="list-style-type: none"> <li><input type="checkbox"/> Recharge the battery for 16 hours.</li> <li><input type="checkbox"/> Operate the <b>Pilot</b> for 1 hr at a flow rate of 120 ml/hr:***** .....</li> </ul> </li> </ul>			
17	<ul style="list-style-type: none"> <li>■ Carry out the electrical tests according to standard EN 60601-1</li> </ul>			

<b>Name:</b>	<b>Date:</b>	<b>Signature:</b>
--------------	--------------	-------------------

Comments:

## 4.4 Flow rate control

### 4.4.1 Measurement with a computer

ISDébit software is required for measuring the flow with a computer. This software is the property of **Fresenius Vial**. Please contact our After Sales Service for any further information.

The operation mode defined by this software follows the project protocol of standard PrEN-60-601-2-24 for **infusion pumps**. It is up to the user to adapt this procedure to the software used.



*In order to purchase the ISDébit flow rate control software, contact the **Fresenius Vial customer service**.*

The test procedure defined below must be carried out using a 50 ml or 20 ml syringe.

#### Equipment required

- Scales coupled to a microcomputer:

Flow rate value	Scales sensitivity
$x \leq 5$ ml/hr	1/10000th
$5$ ml/hr $< x \leq 30$ ml/hr	1/1000th
$x > 30$ ml/hr	1/100th

- Multi scales acquisition programme.
- Test tube or beaker with 1 ml graduating
- Liquid: distilled water and oil
- Luer lock type plastic syringe (50 or 20 ml).
- Catheter extension with Luer Lock (length 100 cm, inside diameter 2.5 mm).
- Needle:

Flow rate value	Needle type
$x \leq 30$ ml/hr	G26
$x > 30$ ml/hr	G18 or G21

#### Installation

- According to the installation drawings shown below.

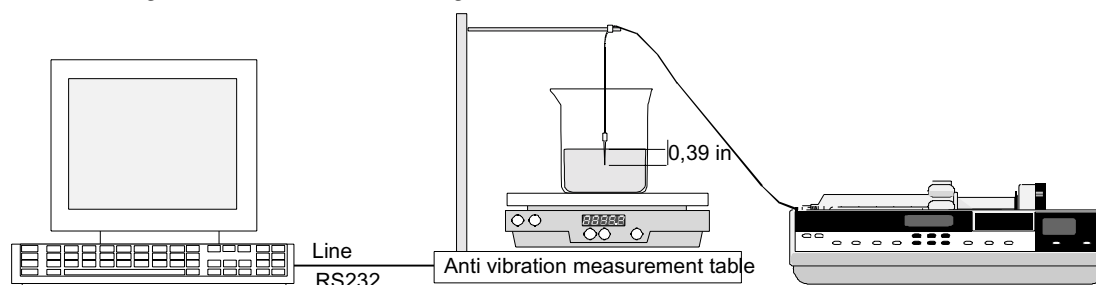

*Make sure the horizontal installation plane is respected.*

- Fill the syringe with 50 ml of distilled water.
  - Prime to eliminate any air bubbles.
- Secure the female Luer Lock end piece of the catheter extension onto the syringe and the male Luer lock end piece onto the needle.
- Fit the syringe onto the device.
- Fill the test tube ensuring the needle is dipped in the liquid (> 1 cm).
  - Add several drops of oil to create a greasy film on the surface of the liquid. This way the user will avoid any measurement error due to evaporation of the liquid.
- Place the test tube in the centre of the scales platform.
- Place the needle inside the test tube.



**The infusion line (needle/catheter extension) must not rest on the scales/test tube assembly.**

- Press "ON" (device in mains supply mode).
  - Prime the infusion line using the "BOLUS" key.
  - Check that there are no air bubbles.

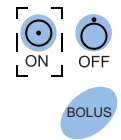

### Operating mode



*The software works following the operating mode described in the PrEN-60-601-2-24 standard project for **infusion pumps**.*

- Start the acquisition programme for the scales.
- Enter the necessary data to launch the programme without validating the flow rate.
- Adjust the scales to the specified flow rate.
- Confirm the flow rate on the microcomputer so that the automatic setting of the scales can take place.
- Start the infusion by pressing the "CONFIRM" key, when **00.00** appears on the scales display screen.
- When the specified time is over, note the error percentage displayed on the screen.



## 4.4.2 Measurement with scales

### Equipment required

- Stop clock
- Scales

Flow rate value	Scales sensitivity
$x \leq 5$ ml/hr	1/10000th
$5 \text{ ml/hr} < x \leq 30$ ml/hr	1/1000th
$x > 30$ ml/hr	1/100th

- Test tube or beaker with 1 ml graduating
- Liquid: distilled water and oil
- Luer lock type plastic syringe (50 or 20 ml)
- Catheter extension with Luer Lock (length 100 cm, inside diameter 2,5 mm).
- Needle:

Flow rate value	Needle type
$x < 30$ ml/hr	G26
$x > 30$ ml/hr	G18 or G21

### Installation

- According to the installation drawings shown below.

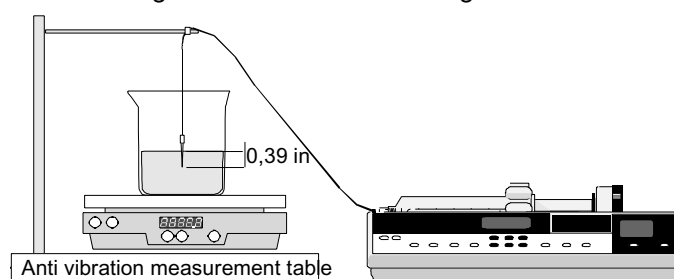

*Make sure the horizontal installation plane is respected.*

- Fill the syringe with 50 ml of distilled water.
- Prime to eliminate any air bubbles.
- Secure the female Luer Lock end piece of the catheter extension onto the syringe and the male Luer lock end piece onto the needle.
- Fit the syringe onto the device.
- Fill the test tube ensuring the needle is dipped in the liquid (> 1 cm).
- Add several drops of oil to create a greasy film on the surface of the liquid. This way the user will avoid any measurement error due to evaporation of the liquid.
- Place the test tube in the centre of the scales platform.
- Place the needle inside the test tube.



The infusion line (needle/catheter extension) must not rest on the scales/test tube assembly.

- Press "ON" (device in mains supply mode).
  - Prime the infusion line using the "BOLUS" key.
  - Check that there are no air bubbles.

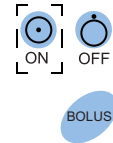

### Operating mode

- Select a flow rate.



For low flow rates (< 5 ml/hr), validate and wait for the infusion to stabilise for 1 hour. For higher flow rates, wait for 10 to 30 minutes after infusion.

- Set the scales at **00.00** g.
- Start infusion by pressing the "CONFIRM" key, and start the stop clock at the same time, (if necessary make a note of the stop clock start value).
- Press the "STOP INFUSION" key to stop the test one hour later.
- Note the value in grams of the "infused" liquid.
- Calculate the difference between the design value and the real value.



1 gram = 1 ml.

- The error percentage can be calculated from this difference :

$$\frac{(\text{Real value} - \text{Design value})}{\text{Design value}} \times 100 = \text{Error percentage}$$

### 4.4.3 Measurement using a test tube

#### Equipment required

- Stop clock.
- Test tube or beaker with 1 ml graduating
- Liquid: distilled water and oil
- Luer lock type plastic syringe (50 or 20 ml)
- Catheter extension with Luer Lock (length 100 cm, inside diameter 2,5 cm).
- Needle:

Flow rate value	Needle type
$x < 1,01 \text{ fl oz/hr}$	G26
$x > 1,01 \text{ fl oz/hr}$	G18 or G21

#### Installation

- According to the installation drawings shown below.

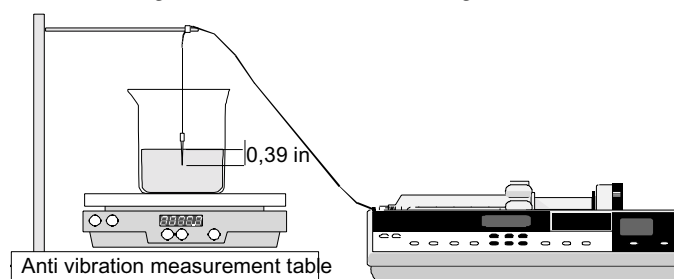

*Make sure the horizontal installation plane is respected.*

- Fill the syringe with 50 ml of distilled water.
  - Prime to eliminate any air bubbles.
- Secure the female Luer Lock end piece of the catheter extension onto the syringe and the male Luer lock end piece onto the needle.
- Fit the syringe onto the device.
- Fill the test tube ensuring the needle is dipped in the liquid (> 1 cm).
  - Add several drops of oil to create a greasy film on the surface of the liquid. This way the user will avoid any measurement error due to evaporation of the liquid.
  - Place the needle inside the test tube.

### Operating mode

- Select a flow rate.



*For low flow rates (< 5 ml/hr), validate and wait for the infusion to stabilise for 1 hour. For higher flow rates, wait for 10 to 30 minutes after infusion.*

- Start infusion by pressing the "CONFIRM" key, and start the stop clock at the same time, (if necessary make a note of the stop clock start value).
- Once the whole infused syringe is in the test tube, calculate the difference between the design value and the real value:  
Real flow rate = 50 ml/time in hours
- The error percentage can be calculated from this difference :

$$\frac{(\text{Real value} - \text{Design value})}{\text{Design value}} \times 100 = \text{Error percentage}$$





## 4.5 Cleaning and disinfection

The syringe pump is part of the patient's immediate environment. It is advisable to clean and disinfect the external surfaces of the device on a daily basis in order to protect both patient and personnel from any risks of contamination.

- Disconnect the power cable from the wall socket before cleaning.
- Do not place in an AUTOCLAVE or IMMERSE the device, and do not allow liquid to penetrate inside the equipment case or power supply cover.
  - Use a cloth soaked in DETERGENT-DISINFECTANT, diluted in water if necessary, to eliminate micro organisms.
  - Avoid excessively abrasive brushing that could scratch the case.
  - Do not rinse or wipe the surfaces.
- If the equipment is used in a department with severe contamination risks, after disinfecting by wiping with a damp cloth, equipment should be left in the room during aerial disinfection.

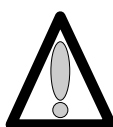

### Do not use TRICHLOROETHYLENE-DICHLOROETHYLENE.

- TRICHLOROETHYLENE-DICHLOROETHYLENE:
  - AMMONIA.
  - AMMONIUM CHLORIDE
  - CHLORINE AND AROMATIC HYDROCARBON.
  - ETHYLENE DICHLORIDE-METHYLENE CHLORIDE
  - CETONE based cleaning products.

These aggressive agents could damage the plastic parts and lead to apparatus malfunctions.

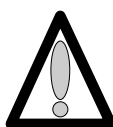

### Also beware of ALCOHOL SPRAYS (20% -40% alcohol) that tarnish and crack the plastic and fail to provide the cleaning action required prior to disinfection.

For further information, please contact the competent department in your hospital for supply of the appropriate cleaning and disinfecting products.

---

## 4.6 Storage

---

In case of prolonged storage, it is advisable to disconnect the battery using the battery access door on the bottom of the device. This operation should be done by an experienced technician.

The equipment must be stored in a dry and cool place.

- The recommended environmental temperature conditions for storage of the equipment are between 0°C and 40°C.
- Relative humidity tolerated: max. 85%, no condensation.

Fully recharge the battery before using the equipment to avoid any risks caused by micro power cuts in the mains supply and to ensure maximum autonomy.

## 5 Diagnosis

### 5.1 Troubleshooting

Problem	Cause	Solution
End of infusion detected too early (at approximately 10 ml).	<ul style="list-style-type: none"> <li>■ The syringe used does not correspond to the selected one.</li> </ul>	<ul style="list-style-type: none"> <li>■ Change the syringe.</li> </ul>
No pre-alarm or alarm at end of infusion.		
Too much flow rate or displacement control drift.		
Occlusion alarm upon start-up	<ul style="list-style-type: none"> <li>■ Inappropriate calibration of the force sensor.</li> </ul>	<ul style="list-style-type: none"> <li>■ Recalibrate the force sensor (see "E t R.9 Force sensor calibration.").</li> </ul>
	<ul style="list-style-type: none"> <li>■ Force sensor out of order.</li> </ul>	<ul style="list-style-type: none"> <li>■ Check the force sensor (see "E t R.9 Force sensor calibration.").</li> </ul>
	<ul style="list-style-type: none"> <li>■ Ribbon cable cut.</li> </ul>	<ul style="list-style-type: none"> <li>■ Replace the ribbon cable (see "Ribbon cable winding kit" operation sheet).</li> </ul>
Occlusion alarm during operation.	<ul style="list-style-type: none"> <li>■ Pressure limit selected is too low.</li> </ul>	<ul style="list-style-type: none"> <li>■ Select a medium pressure limit.</li> </ul>
	<ul style="list-style-type: none"> <li>■ Inappropriate calibration of the force sensor.</li> </ul>	<ul style="list-style-type: none"> <li>■ Recalibrate the force sensor (see "E t R.9 Force sensor calibration.").</li> </ul>
	<ul style="list-style-type: none"> <li>■ Ribbon cable cut.</li> </ul>	<ul style="list-style-type: none"> <li>■ Replace the ribbon cable (see "Ribbon cable winding kit" operation sheet).</li> </ul>
Disengagement alarm upon start-up	<ul style="list-style-type: none"> <li>■ Faulty disengagement micro-switch.</li> </ul>	<ul style="list-style-type: none"> <li>■ Replace the micro-switch (see "Syringe detection system" operation sheet)</li> </ul>
Syringe piston detection alarm not justified.	<ul style="list-style-type: none"> <li>■ Faulty photoelectric cell and/or syringe piston obturator.</li> </ul>	<ul style="list-style-type: none"> <li>■ Check the syringe clamp (see "Checking the syringe clamp").</li> </ul>
Syringe body clamp alarm not justified.		
Syringe fin detection alarm not justified.	<ul style="list-style-type: none"> <li>■ Faulty switch and/or fin detection connections.</li> </ul>	<ul style="list-style-type: none"> <li>■ Check the fin detection system 'see "Checking the fin detection system").</li> </ul>
Display fault: segments, Leds	<ul style="list-style-type: none"> <li>■ Control transistors and/or display board connections.</li> </ul>	<ul style="list-style-type: none"> <li>■ Check the display (see "Checking the indicator lights").</li> <li>■ Check the connectors.</li> </ul>
After a fall.	<ul style="list-style-type: none"> <li>■ Damaged mechanical elements.</li> </ul>	<ul style="list-style-type: none"> <li>■ Check that the input bearing and mechanical assembly are intact.</li> </ul>



## 5.2 Error messages

Error code	Description	Recommended action
<b>Electronic control and software* errors</b>		
<i>Er 03</i>	<ul style="list-style-type: none"> <li>■ Communication fault</li> </ul>	<ul style="list-style-type: none"> <li>■ Reconfigure the <b>Pilot</b> (see “Basic operation parameter configuration menu”).</li> </ul>
<i>Er 16</i>	<ul style="list-style-type: none"> <li>■ Time dater</li> </ul>	
<i>Er 10</i>	<ul style="list-style-type: none"> <li>■ Internal RAM error.</li> </ul>	
<i>Er 20</i>	<ul style="list-style-type: none"> <li>■ External RAM error.</li> </ul>	
<i>Er 30</i>	<ul style="list-style-type: none"> <li>■ EEPROM error.</li> </ul>	
<i>Er 40</i>	<ul style="list-style-type: none"> <li>■ EEPROM error.</li> </ul>	
<i>Er 44</i>	<ul style="list-style-type: none"> <li>■ EEPROM error.</li> </ul>	
<i>Er 50</i>	<ul style="list-style-type: none"> <li>■ ADC error.</li> </ul>	<ul style="list-style-type: none"> <li>■ Check the ADC (see “Checking the ADC”).</li> </ul>
<i>Er 55</i>	<ul style="list-style-type: none"> <li>■ Time dater</li> </ul>	<ul style="list-style-type: none"> <li>■ Reconfigure the <b>Pilot</b> (see “Current operation parameter configuration menu”).</li> </ul>
<i>Er 60</i>	<ul style="list-style-type: none"> <li>■ Syringe parameter error.</li> </ul>	
<i>Er 70</i>	<ul style="list-style-type: none"> <li>■ Motor frequency error.</li> </ul>	
<i>Er 80</i>	<ul style="list-style-type: none"> <li>■ Faulty keyboard.</li> <li>■ Short circuit in the keyboard.</li> </ul>	<ul style="list-style-type: none"> <li>■ Check the keyboard.</li> </ul>
	<ul style="list-style-type: none"> <li>■ Electromagnetic disturbance exceeding standard limits.</li> </ul>	<ul style="list-style-type: none"> <li>■ Check the operation environment of the <b>Pilot</b>.</li> </ul>
<p>* : When rewriting the EEPROM, when the equipment is switched off, the Check Sum is rewritten in the memory to save the parameters.            If the Hardware cut-off delay is shorter than the software cut-off delay, the equipment is switched off before the EEPROM is fully rewritten: Check Sum not compliant.            Err(-)0 or CFPc: When the equipment is in CFPc, reconfiguration is compulsory: Faulty WATCH DOG.</p>		
<b>Motor errors</b>		
<i>Er 01</i>	<ul style="list-style-type: none"> <li>■ Motor control failure.</li> </ul>	<ul style="list-style-type: none"> <li>■ Check the motor power supply.</li> <li>■ Replace the motor.</li> </ul>
	<ul style="list-style-type: none"> <li>■ Motor fault.</li> </ul>	

Error code	Description	Recommended action
<b>Plunger advance errors</b>		
<i>Er 32</i>	■ Error over a short range.	<ul style="list-style-type: none"> <li>■ Check the connectors.</li> <li>■ Check that the potentiometer is tightened.</li> <li>■ Check the ADC (see “Checking the ADC”).</li> <li>■ Check the position sensor (see “Checking the position sensor.”).</li> </ul>
<i>Er 52</i>	■ Error during compensation for play.	
<i>Er 72</i>	■ Error over the whole length.	
<i>Er 82</i>	■ Error in relation to the flow rate.	
<b>Calculation parameter errors (motor and flow rate)</b>		
<i>Er 14</i>	■ Motor period calculation error.	<ul style="list-style-type: none"> <li>■ Check the ADC (see “Checking the ADC”).</li> <li>■ Check the position sensor (see “Checking the position sensor.”).</li> </ul>
<i>Er 24</i>	■ Motor rotation direction error.	
<i>Er 34</i>	■ Flow rate/period calculation error.	
<b>Configuration errors</b>		
<i>CFPe</i>	■ The configuration self-test upon start-up was not satisfactory.	■ Reconfigure the <b>Pilot</b> (see “Pressure parameter configuration menu” and “Current operation parameter configuration menu”).

## 6 Operation sheets

This chapter lists the set of dismantling/remounting sheets.





## N°1, Procedure: Display and central unit boards

### Safety:

For safety reasons, the technician should not carry any maintenance when the device is connected to the 230 V mains supply voltage.

Disconnect the mains power supply cable.

### Tools required:

- 1 Posidriv Z1 screwdriver.
- 1 antistatic wriststrap.

### Maintenance level:

Level 2, specialised technician (see documentation on biomedical training).

### Procedure:

#### Access

- Rotate the **Pilot** on the upper case.
- Unscrew the 6 Phillips head screws (ref. 1) Located at the bottom of the lower case, which tighten the latter to the upper case.
- Keep the **Pilot** assembled and turn it over onto the lower case.
- Remove the upper case making sure the CPU board flat jumper is not accidentally removed in the process.
- Disconnect the CPU board flat jumper.

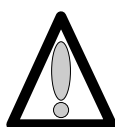

**Hands must not come into contact with the CPU boards.**

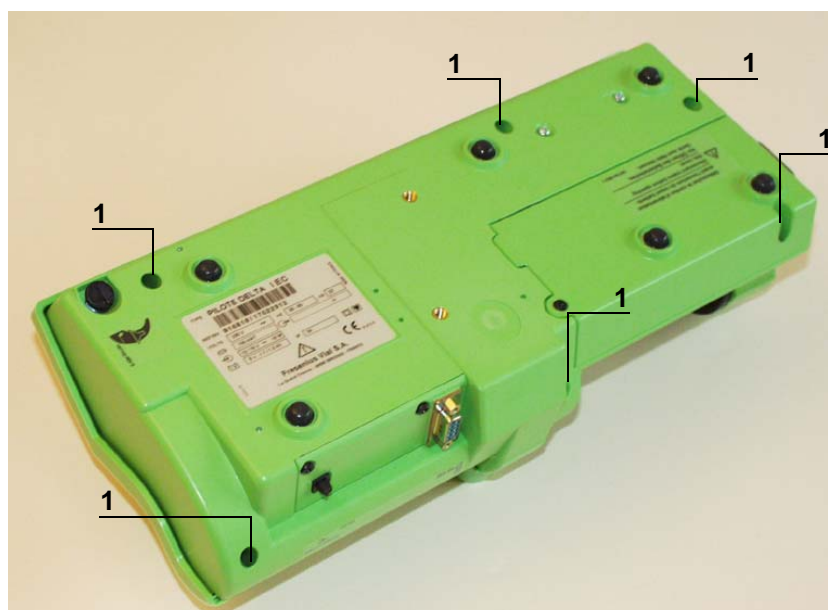

## Dismounting



*When electronic components are handled, it is recommended to wear an antistatic wriststrap linked to ground and to work on an antistatic foam mat.*

- Unscrew the 3 Phillips head screws (ref. 2) located at the display board, which link this to the upper case.
- Remove the battery insulator (rep.3) located on the right.
- Disconnect the black connector (ref. 4).

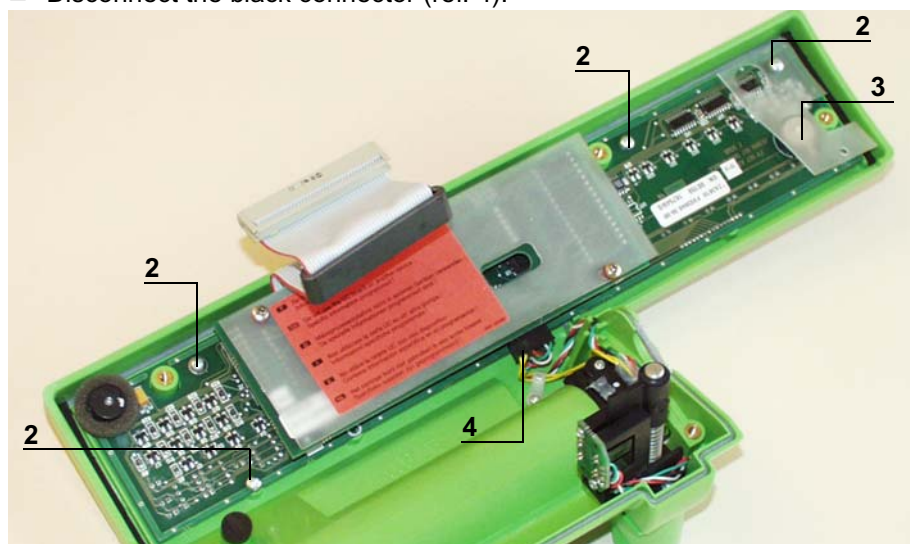

- Lift the display board slightly and remove the display unit flat jumper (ref. 5).

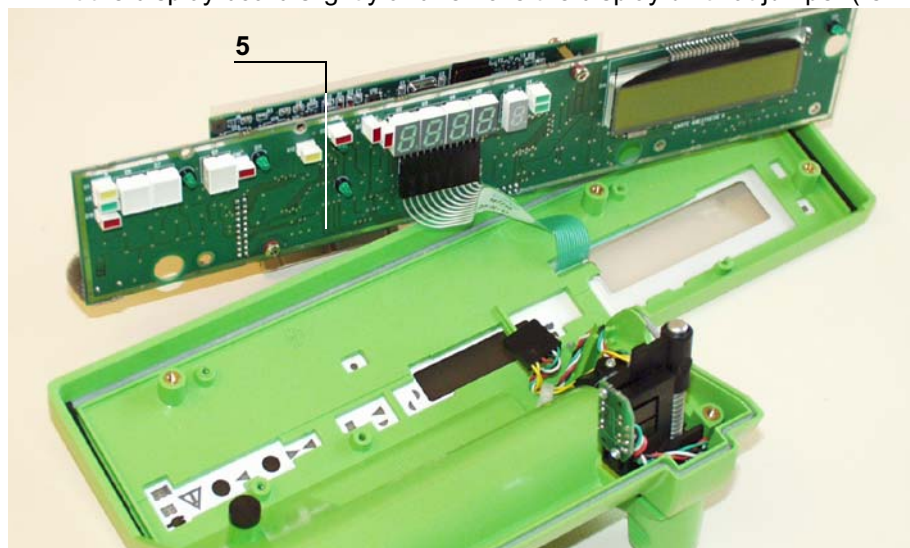

## Reassembly



*A specific type of board corresponds to each **Pilot** "CPU and display board"; It is important to avoid reversing the references between each **Pilot**. This way, that corresponding to your device will be controlled.*

Carry out the same procedures in reverse to reassemble the parts.



*When mounting the display board, it is important to reduce the torque in the plastic inserts so as to avoid causing damage to these.*

*When fitting the upper case, ensure the joint is perfectly positioned in its slot after reassembly.*

Recalibrate the **Pilot** (see "Calibrations") then carry out the regular servicing tests (see "Regular servicing sheet").



## N°2, Procedure: Syringe clamp

### Safety:

For safety reasons, the technician should not carry out any maintenance when the device is connected to the 230 V mains supply voltage.

Disconnect the mains power supply cable.

### Equipment required:

- 1 Posidriv Z1 screwdriver.
- 1 Posidriv Z1 flat screwdriver.

### Maintenance level:

Level 2, specialised technician (see documentation on biomedical training).

### Procedure:

#### Access

- Turn the Pilot over onto the upper case.
- Unscrew the 6 Phillips head screws (ref. 1) located at the bottom of the lower case, which link this to the upper case.
- Keep the Pilot assembled and turn it over onto the lower case.
- Remove the upper case making sure the CPU board flat jumper is not accidentally removed in the process.
- Disconnect the CPU board flat jumper.

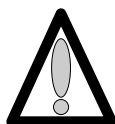

**Hands must not come into contact with the CPU boards.**

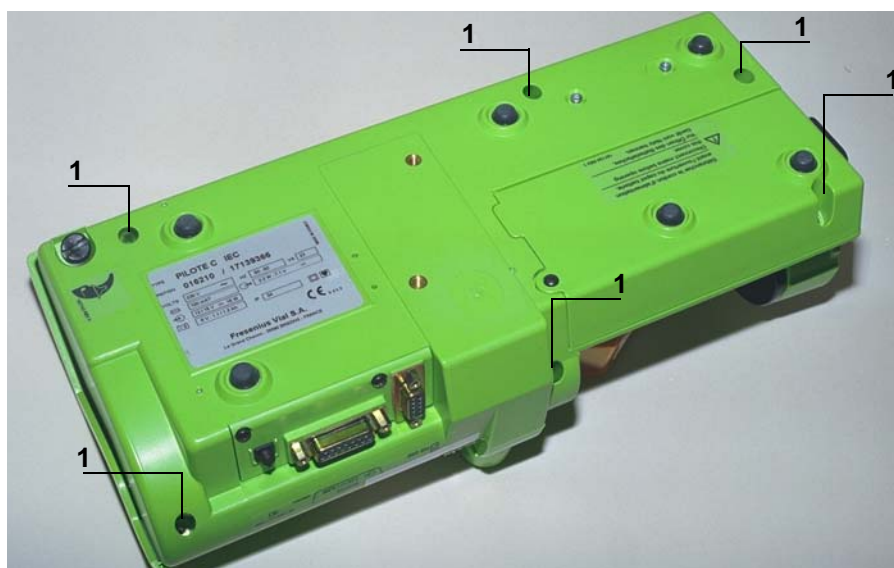

## Dismounting

- Remove the spring retaining ring (ref. 2) located on the syringe clamp shaft, which holds this to the CPU support.
- Remove the obturator and the spring (ref. 3).
- Remove the syringe clamp.

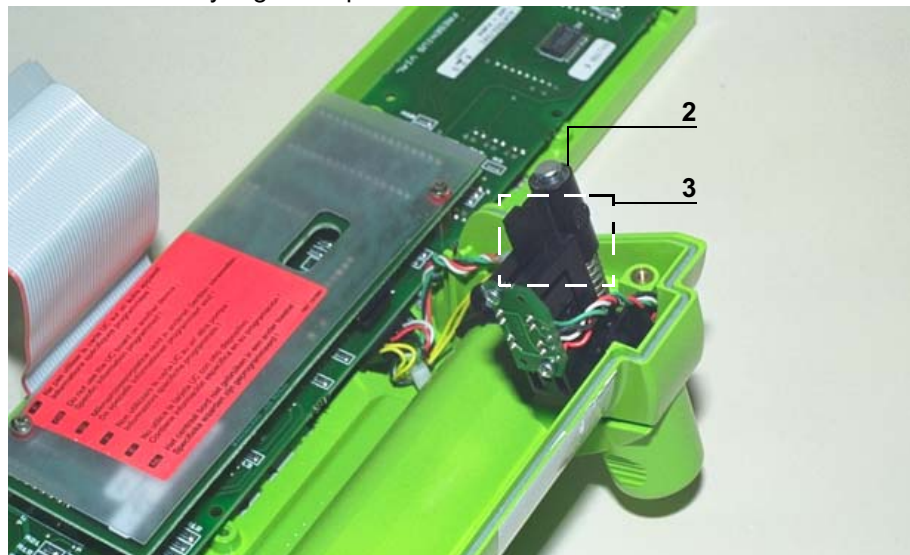

## Reassembly

Carry out the same procedures in reverse to remount the unit.



*When fitting the upper case, ensure the joint is perfectly positioned in its slot after reassembly.*

Perform the regular servicing tests (see "Regular servicing sheet").

## N°3, Procedure: Syringe detection system

### Safety:

For safety reasons, the technician should not carry out any maintenance when the device is connected to the 230 V mains supply voltage.

Disconnect the mains power supply cable.

### Equipment required:

- 1 Posidriv Z1 screwdriver.
- 1 antistatic wriststrap.
- 1 soldering iron
- "RADIEL Sn60Pb RI 1" welding wire (cleaning not required for rewelding) or equivalent.
- Silicone ref. 161249.

### Maintenance level:

Level 2, specialised technician (see documentation on biomedical training).

### Switch replacement procedure:

#### Access

- Turn the **Pilot** over onto the upper case.
- Unscrew the 6 Phillips head screws (ref. 1) located at the bottom of the lower case, which link this to the upper case.
- Keep the **Pilot** assembled and turn it over onto the lower case.
- Remove the upper case making sure the CPU board flat jumper is not accidentally removed in the process.
- Disconnect the CPU board flat jumper.

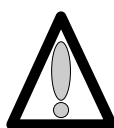

**Hands must not come into contact with the CPU boards.**

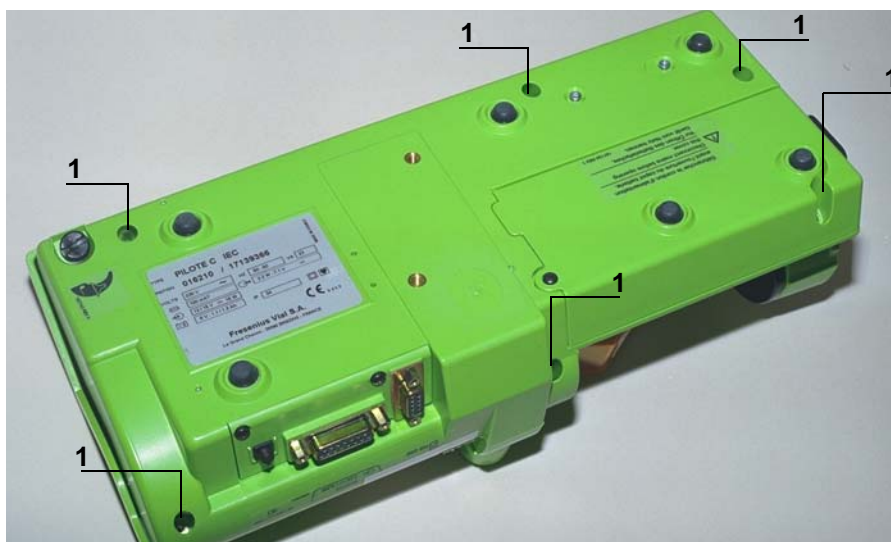

## Dismounting

- Disconnect the connector (ref. 2).
- Unscrew the Phillips head screw (ref. 3) which holds the conductor to the upper case.
- Unscrew the 2 Phillips head screws (ref. 4) which hold the switch support in position.
- Remove the switch assembly.
- Remove the silicone pins.

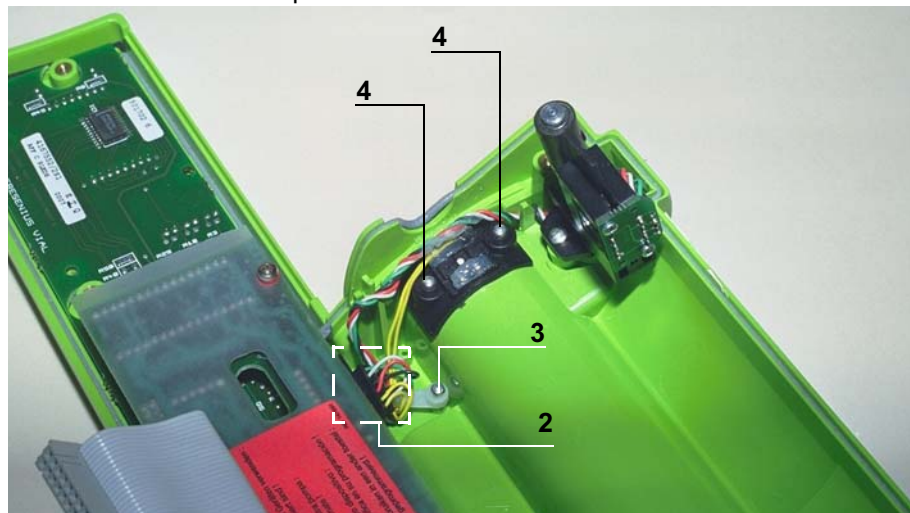

*Welding and unwelding operations are carried out using a soldering iron fitted with a tip in good condition, constantly tapered and clean kept. The temperature of the iron should be between 315°C and 340°C.*

- Unweld the switch wires:
  - Add more weld to facilitate the unwelding process.
  - Heat and pull on the wires one by one.
  - Straighten up the 4 mounting lugs and remove the switch.



## Reassembly

- Place the new switch on the support.
- Bend the mounting lugs towards the inside in order to lock them into position.
- Weld the wires of the new switch:
  - Taper the 2 welding wires and the 2 lugs of the switch to be welded.
  - Place the wires under the bent lugs.
  - Place the welding iron tip on the welding surface.
  - Place the welding wire on the pin surface of the switch to be welded.
  - Remove the welding wire and then the welding iron tip.
  - Check that the welding has been carried out correctly. It should not form a ball, but should lie against the length of the wire.
- Screw the 2 Phillips head screws (ref. 3) which hold the "switch support" assembly in position.



*When mounting the "switch support", it is important to reduce the torque in the plastic inserts so as to avoid causing damage to these.*

- Connect the conductor to the CPU board.
  - Tighten the Phillips head screw holding the conductor (ref. 2).
  - Place 2 silicone pins on the switch contacts in order to insulate these.
- Carry out the same procedures in reverse to remount the unit.



*When fitting the upper case, ensure the joint is perfectly positioned in its slot after reassembly.*

Perform the regular servicing tests (see "Regular servicing sheet").

## Opto replacement procedure:

### Access

- Turn the **Pilot** over onto the upper case.
- Unscrew the 6 Phillips head screws (ref. 1) located at the bottom of the lower case, which link this to the upper case.
- Keep the **Pilot** assembled and turn it over onto the lower case.
- Remove the upper case making sure the CPU board flat jumper is not accidentally removed in the process.
- Disconnect the CPU board flat jumper.



**Hands must not come into contact with the CPU boards.**

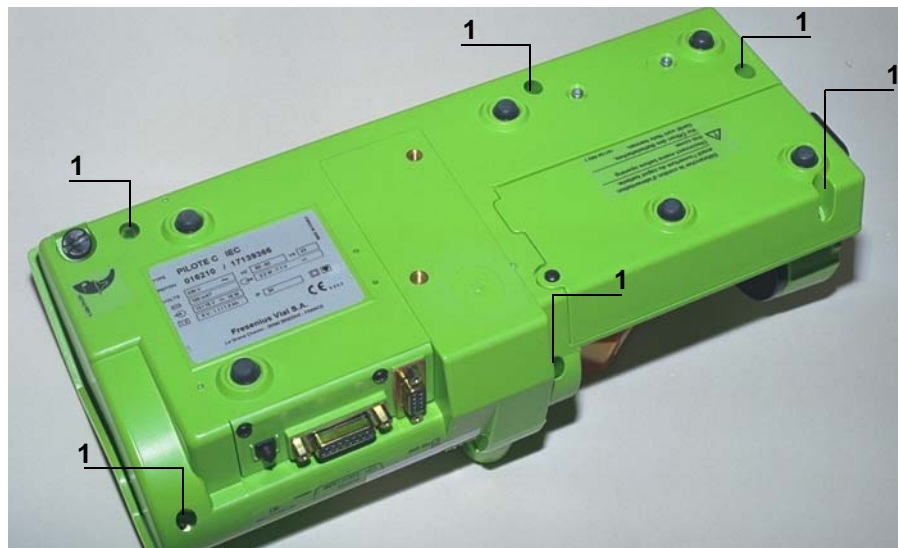

### Dismounting

- Disconnect the connector (ref. 2).
- Unscrew the Phillips head screw (ref. 3) which holds the conductor to the upper case.
- Unscrew the 2 Phillips head screws (ref. 5) which hold the opto PCB in position.
- Remove the opto assembly.

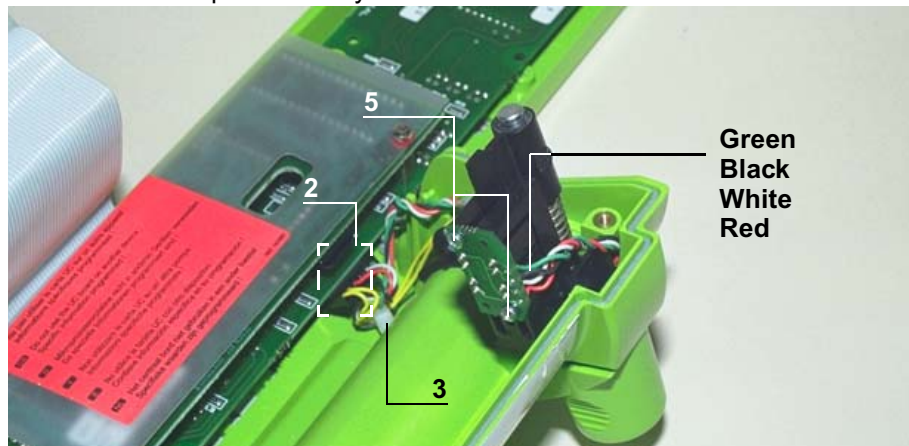

## Reassembly

- Place the new opto assembly on the PCB support.
- Screw the 2 Phillips head screws (ref. 5) which hold the "PCB and opto" assembly in position.



*When mounting the "PCB and opto", it is important to reduce the torque in the plastic inserts so as to avoid causing damage to these.*

- Connect the conductor to the CPU board.
  - Tighten the Phillips head screw holding the conductor (ref. 2).
- Carry out the same procedures in reverse to remount the unit.



*When fitting the upper case, ensure the joint is perfectly positioned in its slot after reassembly.*

Perform the regular servicing tests (see "Regular servicing sheet").



## N°4, Procedure: Motor + Opto + Disk

### Safety:

For safety reasons, the technician should not carry out any maintenance when the device is connected to the 230 V mains supply voltage.

Disconnect the mains power supply cable.

### Equipment required:

- 1 Posidriv Z1 screwdriver.
- 1 antistatic wriststrap.

### Maintenance level:

Level 2, specialised technician (see documentation on biomedical training).

### Procedure:

#### Access

- Turn the Pilot over onto the upper case.
- Unscrew the 6 Phillips head screws (ref. 1) located at the bottom of the lower case, which link this to the upper case.
- Keep the Pilot assembled and turn it over onto the lower case.
- Remove the upper case making sure the CPU board flat jumper is not accidentally removed in the process.
- Disconnect the CPU board flat jumper.

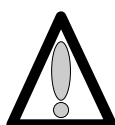

**Hands must not come into contact with the CPU boards.**

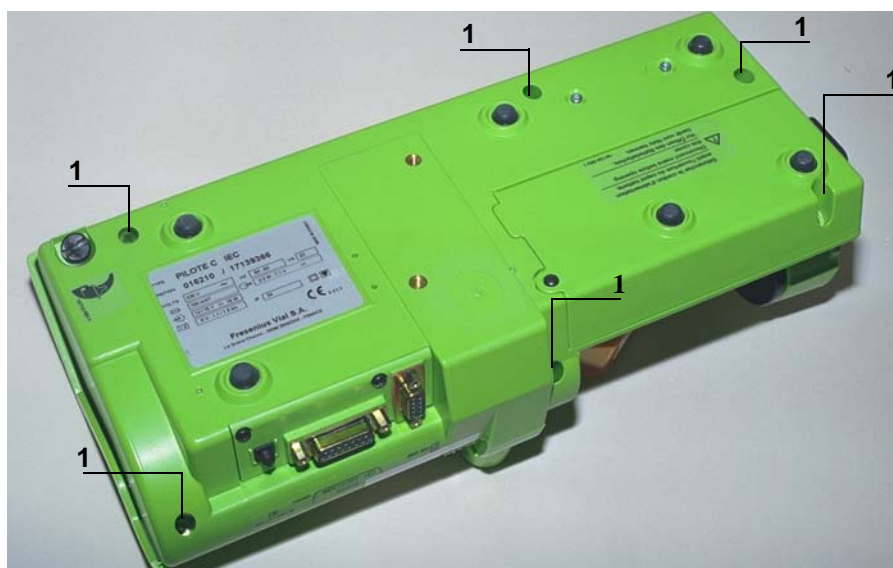

## Dismounting

- Press the syringe pump disengagement lever towards the back of the Pilot as far as possible.
- Maintain this position and slide the whole unit to the back left.
- Remove the plunger guide.
- Disconnect the black connectors (ref. 2).
- Unscrew the flat jumper mounting lug (ref. 3) without removing it.
- Remove the mechanical plunger unit from its slot.
- Disconnect the blue connector from the flat jumper (ref. 4).
- Remove the mechanical plunger unit.

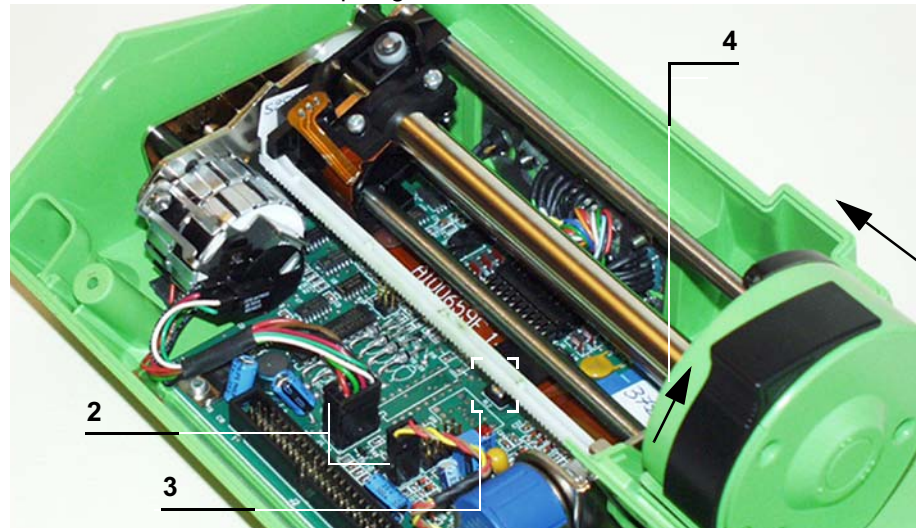

- Unscrew the 2 Phillips head screws (ref. 5).
- Remove the motor, opto and disk assembly.

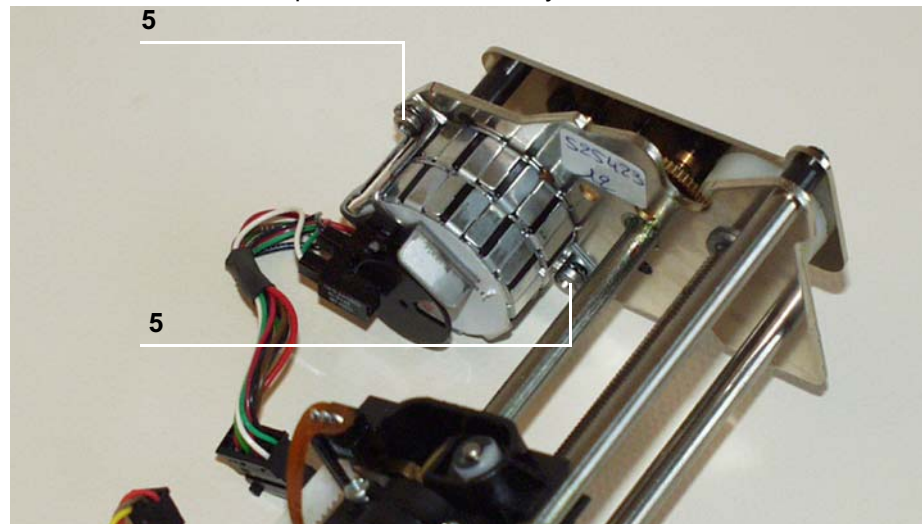

## Reassembly

Carry out the same procedures in reverse to remount the unit.



*When fitting the upper case, ensure the joint is perfectly positioned in its slot after reassembly.*

Perform the regular servicing tests (see "Regular servicing sheet").

## N°5, Procedure: Pressure sensor

### Safety:

For safety reasons, the technician should not carry out any maintenance when the device is connected to the 230 V mains supply voltage.

Disconnect the mains power supply cable.

### Equipment required:

- 1 Posidriv Z1 screwdriver.
- 1 hexagon socket key (2.5).
- 1 soldering iron.
- "RADIEL Sn60Pb RI 1" welding wire (cleaning not required for rewelding) or equivalent.

### Maintenance level:

Level 2, specialised technician (see documentation on biomedical training).

### Procedure:

#### Access

- Turn the **Pilot** over onto the upper case.
- Unscrew the 6 Phillips head screws (ref. 1) located at the bottom of the lower case, which link this to the upper case.
- Keep the **Pilot** assembled and turn it over onto the lower case.
- Remove the upper case making sure the CPU board flat jumper is not accidentally removed in the process.

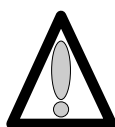

**Hands must not come into contact with the CPU boards.**

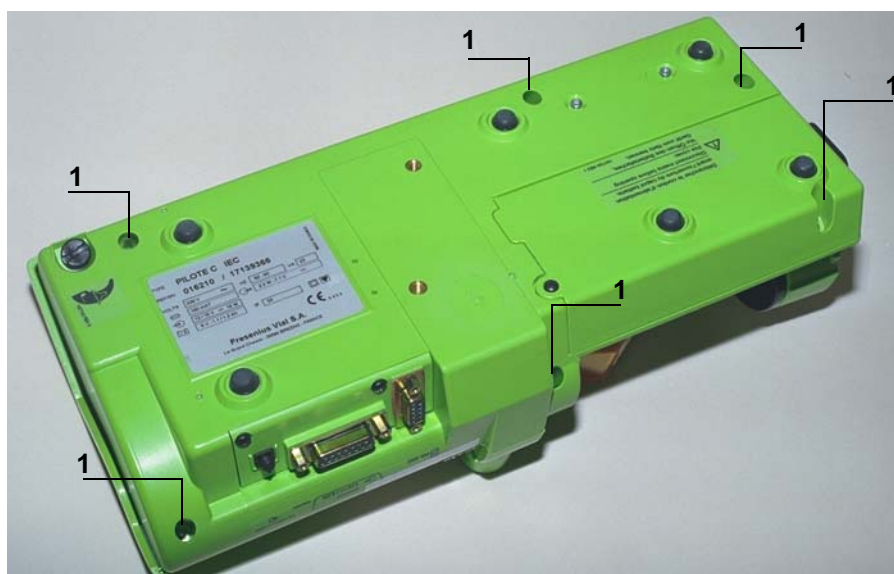

## Dismounting

- Press the syringe pump disengagement lever towards the back of the Pilot as far as possible.
- Maintain this position and slide the whole unit to the back right.
- Remove the plunger guide.
- Unscrew the 3 Phillips head screws (ref. 2) located at the bottom of the plunger end shield which link this to the plunger cover.

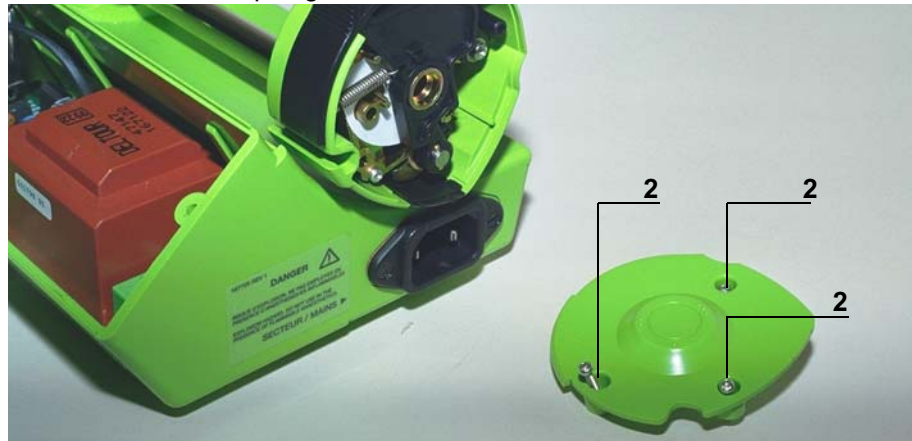

- Remove the plunger end shield, the disengagement lever and its spring (ref. 3) as well as the protective plunger film (ref. 4).
- Remove the plunger cover clip (ref. 5).

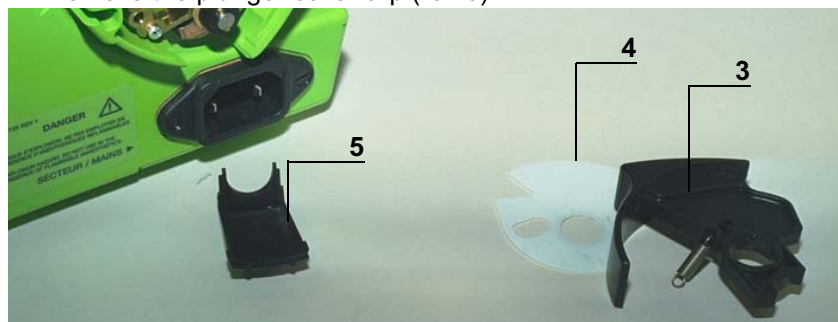

- Unscrew the 2 Phillips head screws (ref. 6 and 7) which link the plunger support to the plunger cover.
- Unscrew and remove the Phillips head screw and the washer (ref. 8) which attach the anti-siphon cam to the anti-siphon arm.
- Remove the cam/arm unit as well as the plunger cover.

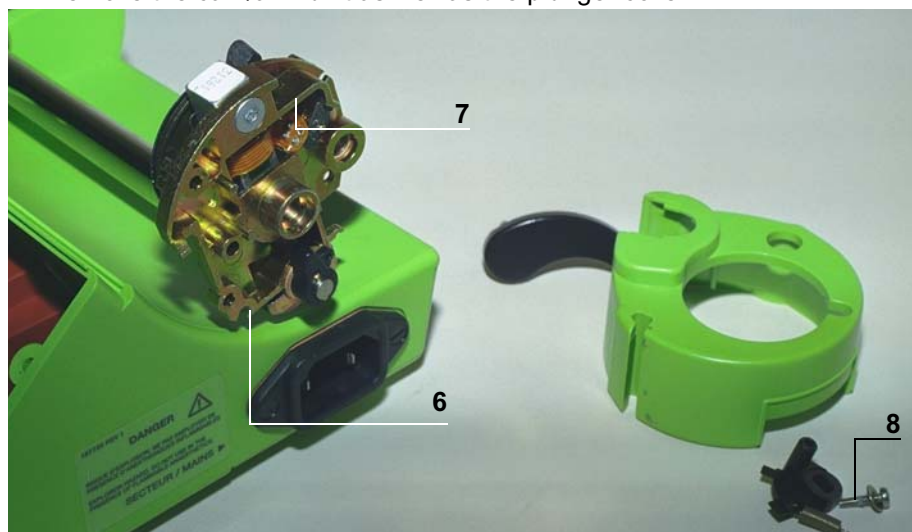



- Remove the bonding pad label.
- Unscrew the 6 hexagon socket screws (ref. 9) and remove the bonding pad.
- Unscrew the 6 hexagon socket screws (ref. 10) and remove the force sensor.

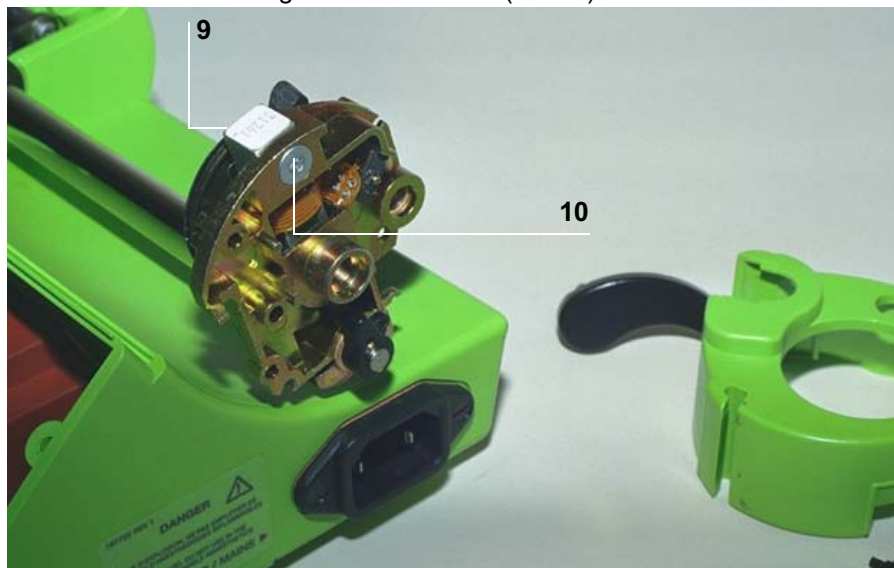

*Welding and unwelding operations are carried out using a soldering iron fitted with a tip in good condition, constantly tapered and clean kept.. The temperature of the iron should be between 315°C and 340°C.*

- Unweld the sensor wires on the flex circuit:



*When dismantling the force sensor, ensure the welding pellets are not damaged.*

- Add more weld to facilitate the unwelding process.
- Heat and pull on the wires one by one.

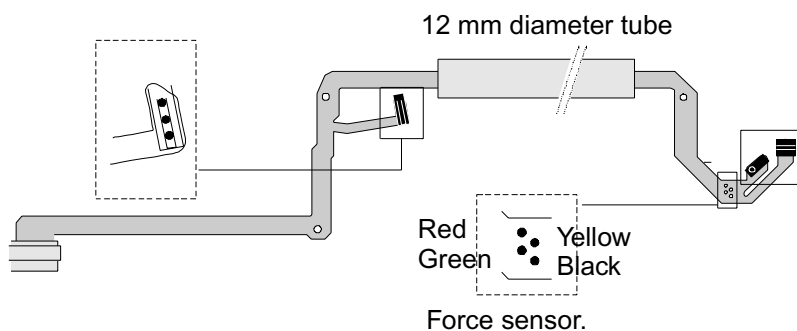

## Reassembly

- Weld the wires to the new sensor, respecting the colour code.
  - Taper the 4 welding wires.
  - Weld the 4 wires.
  - Check that the welding has been carried out correctly. It should not form a ball, but should lie against the length of the wire.
- Impregnate with weak loctite and screw the 6 hexagon socket screws (ref. 10) which attach the sensor to the plunger support.
- Impregnate with weak loctite and screw the 6 hexagon socket screw (ref 9) which hold the new force sensor to the bonding pad.
- Mount the plunger cover onto the plunger support.
- Centre the bonding pad in relation to the plunger cover and lock the bonding pad/sensor unit into position on the plunger support.
- Check the free movement of the removable stop plate.



- Impregnate the screw with weak loctite (ref. 8).
  - Position and screw the cam/anti-siphon arm unit using the Phillips head screw and the washer (ref. 8).
  - Screw the 2 Phillips head screws (ref. 7 and 6) which link the plunger support to the plunger cover.
  - Position the plunger cover clip (ref. 5).
  - Cover the plunger with the protective film, mount the disengagement lever and its spring, and screw the plunger end shield back on (4,3 and 2).
- Carry out the same procedures in reverse to remount the unit.



*When fitting the upper case, ensure the joint is perfectly positioned in its slot after reassembly.*

Recalibrate the pressure sensor (see "Calibrations") then carry out the regular servicing tests (see "Regular servicing sheet").

## N°6, Procedure: Plunger advance control potentiometer

### Safety:

For safety reasons, the technician should not carry out any maintenance when the device is connected to the 230 V mains supply voltage.

Disconnect the mains power supply cable.

### Equipment required:

- 1 Posidriv Z1 screwdriver.
- 1 flat screwdriver.
- 1 flat key (12).
- 1 potentiometer dismantling tool ref. T300869.

### Maintenance level:

Level 2, specialised technician (see documentation on biomedical training).

### Procedure:

#### Access

- Turn the Pilot over onto the upper case.
- Unscrew the 6 Phillips head screws (ref. 1) located at the bottom of the lower housing case, which link this to the upper case.
- Keep the Pilot assembled and turn it over onto the lower case.
- Remove the upper case making sure the CPU board flat jumper is not accidentally removed in the process.
- Disconnect the CPU board flat jumper.

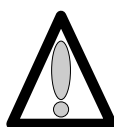

**Hands must not come into contact with the CPU boards.**

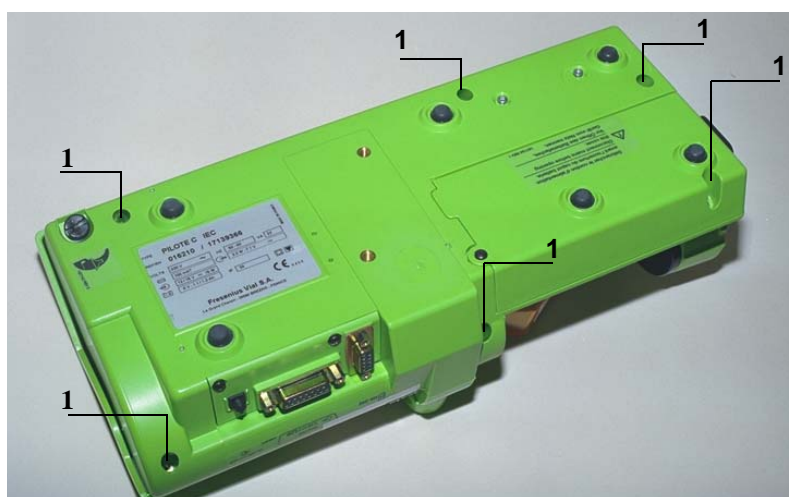

## Dismounting

- Press the syringe pump disengagement lever towards the back of the Pilot as far as possible.
- Maintain this position and slide the whole unit to the back left.
- Remove the plunger guide.
- Disconnect the black connectors (ref. 2).
- Unscrew the flat jumper mounting lug (ref. 3) without removing it.
- Remove the mechanical plunger unit from its slot.
- Disconnect the blue connector from the flat jumper (ref. 4).
- Remove the mechanical plunger unit.
- Unscrew the potentiometer lock nut (ref. 5).
- Remove the tooth lockwasher and the potentiometer.

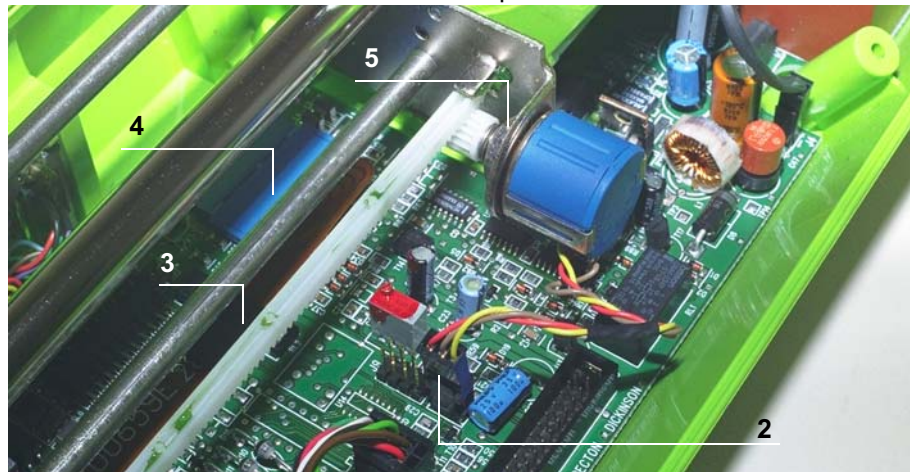

## Reassembly

- Dismount the end shield from the reducer frame.
- Mount the potentiometer onto the end shield (screw the nut onto a thread).
- Position the end shield in equipment T 300 869 and lock it into position using the knurled screw.
- Position the potentiometer in the device and bring it up against the end shield.
- Tighten the potentiometer.
- Extract the end shield from device T 300 869.
- Mount the pinion on the potentiometer (match up the indexing plane).
  - The larger diameter of the pinion must be flattened against the potentiometer.
- With the potentiometer facing you, turn the pinion anticlockwise until it blocks, then turn it  $\frac{1}{4}$  of a turn in the opposite direction.
- Mount the moving mechanical assembly onto the reducer frame.
- Slide the end shield onto the guides and rack.
  - Check the position of the input bearing which must be on the plunger side.
  - Ensure the flex circuit is not damaged when mounting (folding).
- Secure the end shield using the three M3x3 TC screws.
- Secure the input bearing using the two M3x3 TC screws.



*When fitting the upper case, ensure the joint is perfectly positioned in its slot after reassembly.*

Recalibrate the position sensor (see "Calibrations") then carry out the regular servicing tests (see "Regular servicing sheet").

## N°7, Procedure: Plunger cover and/or disengagement lever + anti-siphon arm

### Safety:

For safety reasons, the technician should not carry out any maintenance when the device is connected to the 230 V mains supply voltage.

Disconnect the mains power supply cable.

### Equipment required:

- 1 Posidriv Z1 screwdriver.

### Maintenance level:

Level 2, specialised technician (see documentation on biomedical training).

### Procedure:

#### Access

- Press the syringe pump disengagement lever towards the back of the Pilot as far as possible.
- Maintain this position and slide the whole unit to the back right.

#### Dismounting

- Unscrew the 3 Phillips head screws (ref. 1) located at the bottom of the plunger end shield which links this to the plunger cover.
- Remove the plunger end shield (ref. 2), the disengagement lever and its spring (ref. 3) as well as the protective plunger film (ref. 4).
- Unscrew and remove the Phillips head screw and the washer (ref. 5) which attach the anti-siphon cam to the anti-siphon arm.
- Remove the cam/anti-siphon arm assembly (ref. 6).

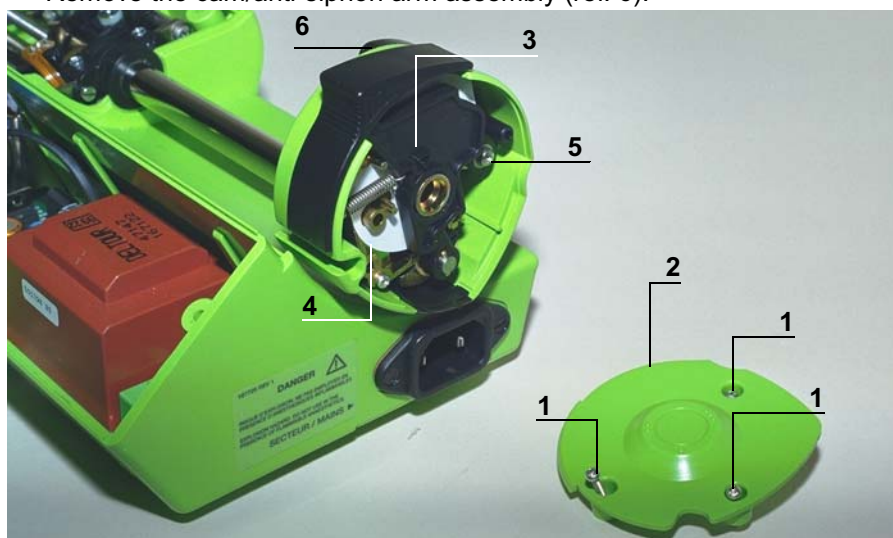

## Reassembly

Carry out the same procedures in reverse to remount the unit.

- Impregnate the screw with weak loctite (ref. 5) before mounting the cam and arm assembly.



*When fitting the upper case, ensure the joint is perfectly positioned in its slot after reassembly.*

Perform the regular servicing tests (see "Regular servicing sheet").

## N°8, Procedure: Power supply board

### Safety:

For safety reasons, the technician should not carry out any maintenance when the device is connected to the 230 V mains supply voltage.

Disconnect the mains power supply cable.

### Equipment required:

- 1 Posidriv Z1 screwdriver.
- 1 small flat screwdriver
- 1 antistatic wriststrap.

### Maintenance level:

Level 2, specialised technician (see documentation on biomedical training).

### Procedure:

#### Access

- Turn the **Pilot** over onto the upper case.
- Unscrew the 6 Phillips head screws (ref. 1) located at the bottom of the lower case, which link this to the upper case.
- Keep the **Pilot** assembled and turn it over onto the lower case.
- Remove the upper case making sure the CPU board flat jumper is not accidentally removed in the process.
- Disconnect the CPU board flat jumper.

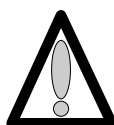

Hands must not come into contact with the CPU boards.

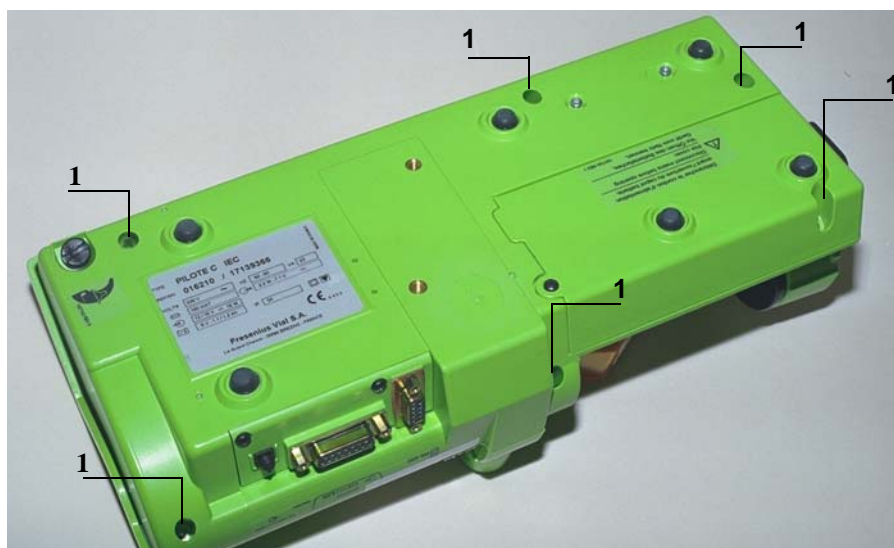

## Dismounting

- Press the syringe pump disengagement lever towards the back of the Pilot as far as possible.
- Maintain this position and slide the whole unit to the back left.
- Remove the syringe pump guide.
- Disconnect the black connectors.



*When electronic components are handled, it is recommended to wear an antistatic wriststrap linked to ground and to work on an antistatic foam mat.*

- Unscrew the flat jumper mounting lug (ref 2) without removing it.
- Remove the mechanical plunger unit from its slot.
- Disconnect the blue connector from the flat jumper (ref. 3).
- Remove the mechanical plunger unit.
- Disconnect the black connectors (ref 4, ref 5, ref.6, ref.7, ref.8, ref.9).
- Unscrew the 3 Phillips head screws (ref. 10) located on the power supply board, which link this to the lower case.
- Unscrew the 2 Phillips head screws (ref. 11) located on lower case, which link this to the power supply board.
- Remove the power supply board.

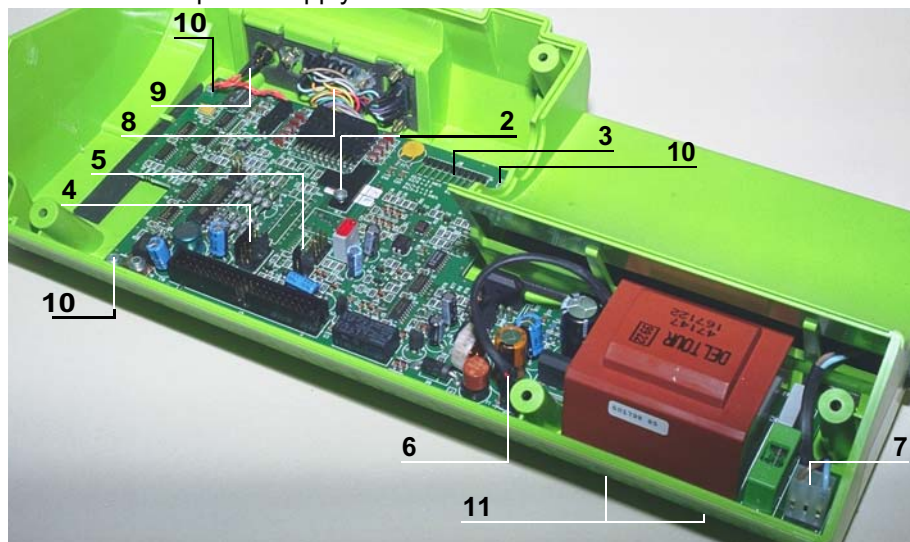

## Reassembly

Carry out the same procedures in reverse to remount the unit.



*When fitting the upper case, ensure the joint is perfectly positioned in its slot after reassembly.*

Recalibrate the force sensor (see "Calibrations") then carry out the regular servicing tests (see "Regular servicing sheet").



## N°9, Procedure: Battery holder and battery

### Safety:

For safety reasons, the technician should not carry out any maintenance when the device is connected to the 230 V mains supply voltage.

Disconnect the mains power supply cable.

### Equipment required:

- 1 Posidriv Z1 screwdriver.

### Maintenance level:

Level 2, specialised technician (see documentation on biomedical training).

### Procedure:

#### Access

- Turn the **Pilot** over onto the upper case.

#### Dismounting

- Unscrew the 2 Phillips head screws (ref. 1) to be found in the lower case battery holder kit, which link this to the lower case.
- Swivel the battery holder and remove the battery.
- Disconnect this.



#### Reassembly

Carry out the same procedures in reverse to remount the unit.



*It is recommended to perform a full loading and unloading cycle to ensure the battery is in working condition.*

Perform the regular servicing tests (see "Regular servicing sheet").



## N°10, Procedure: Rear plug support

### Safety:

For safety reasons, the technician should not carry out any maintenance when the device is connected to the 230 V mains supply voltage.

Disconnect the mains power supply cable.

### Tools required:

- 1 Posidriv Z1 screwdriver.

### Maintenance level:

Level 2, specialised technician (see documentation on biomedical training).

### Procedure:

#### Access

- Rotate the **Pilot** on the upper case.
- Unscrew the 6 Phillips head screws (ref. 1) Located at the bottom of the lower case, which tighten the latter to the upper case.
- Keep the **Pilot** assembled and turn it over onto the lower case.
- Remove the upper case making sure the CPU board flat jumper is not accidentally removed in the process.
- Disconnect the CPU board flat jumper.

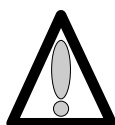

**Hands must not come into contact with the CPU boards.**

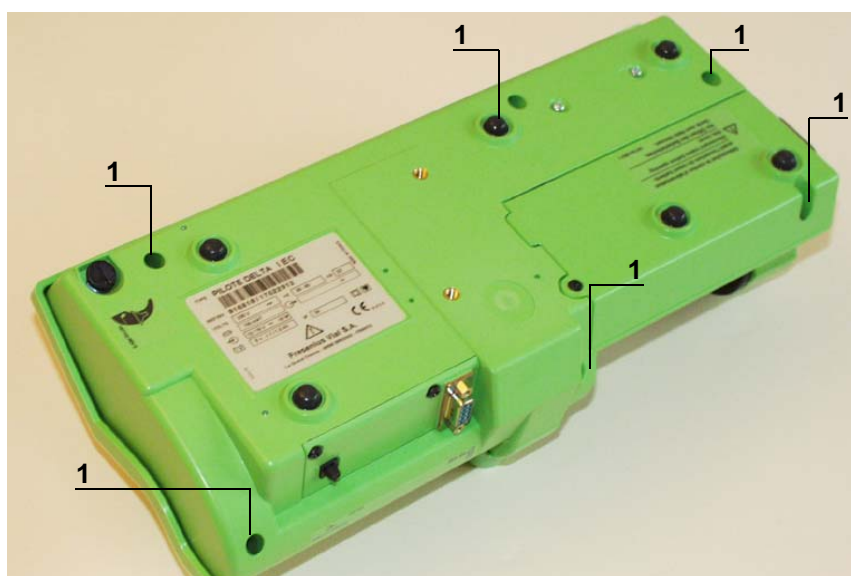

## Dismounting

- Disconnect the two black connectors (ref 2 and ref 3).
- Unscrew the 2 Phillips head screws (ref. 4) located on the cabled plug support, which link this to the lower case.
- Remove the cabled plug support.

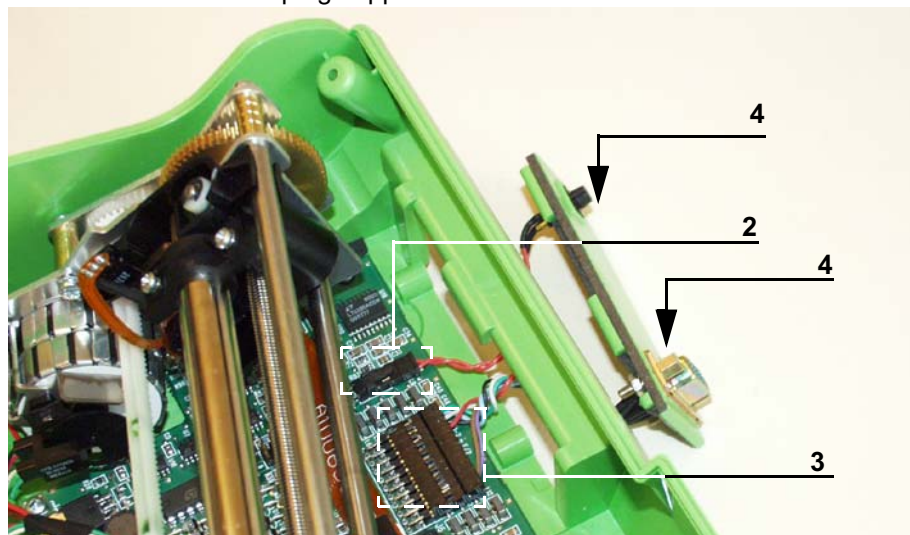

## Reassembly

Carry out the same procedures in reverse to remount the unit.

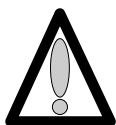

**If the number of rear door connector points is different to the number of power supply board points, make the connections as described below.**

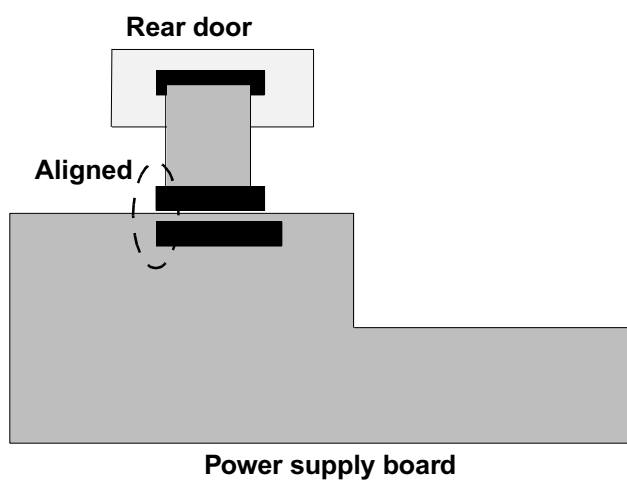

Perform the regular servicing tests (see "Regular servicing sheet").

## N°11, Procedure: Ribbon cable winding kit

### Safety:

For safety reasons, the technician should not carry out any maintenance when the device is connected to the 230 V mains supply voltage.

Disconnect the mains power supply cable.

### Tools required:

- 1 Posidriv Z1 screwdriver.

### Maintenance level:

Level 2, specialised technician (see documentation on biomedical training).

### Procedure:

#### Access

- Rotate the **Pilot** on the upper case.
- Unscrew the 6 Phillips head screws (ref. 1) Located at the bottom of the lower case, which tighten the latter to the upper case.
- Keep the **Pilot** assembled and turn it over onto the lower case.
- Remove the upper case making sure the CPU board flat jumper is not accidentally removed in the process.

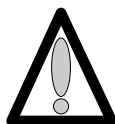

**Hands must not come into contact with the CPU boards.**

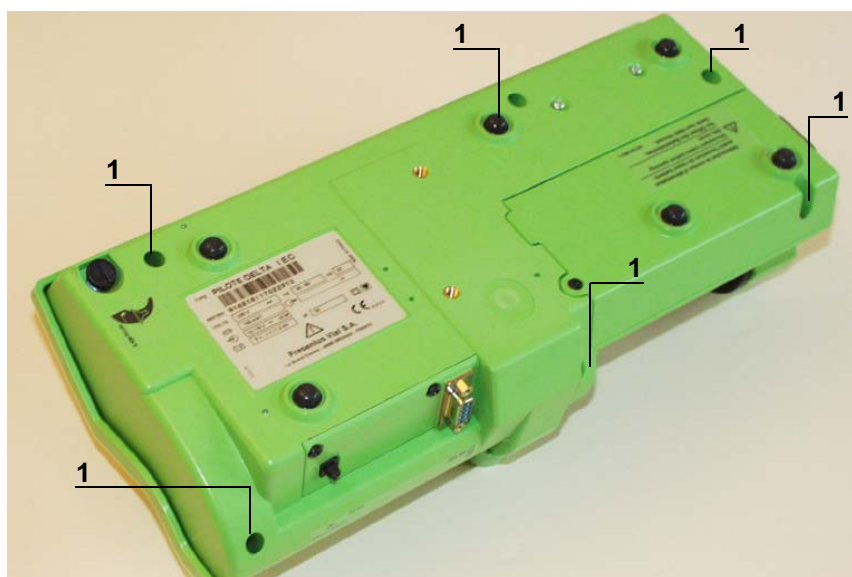

## Dismounting

- Press the syringe pump disengagement lever towards the back of the Pilot as far as possible.
- Maintain this position and slide the whole unit to the back left.
- Remove the plunger guide.
- Disconnect the black connectors (ref 2 and ref 3).



*When electronic components are handled, it is recommended to wear an antistatic wriststrap linked to ground and to work on an antistatic foam mat.*

- Unscrew the flat jumper tongue (ref 4) without removing it.
- Remove the mechanical plunger unit from its slot.
- Disconnect the blue connector (ref 5) from the flat jumper.
- Remove the mechanical plunger unit.
- Fully unscrew and remove the guiding tongue (ref 4).

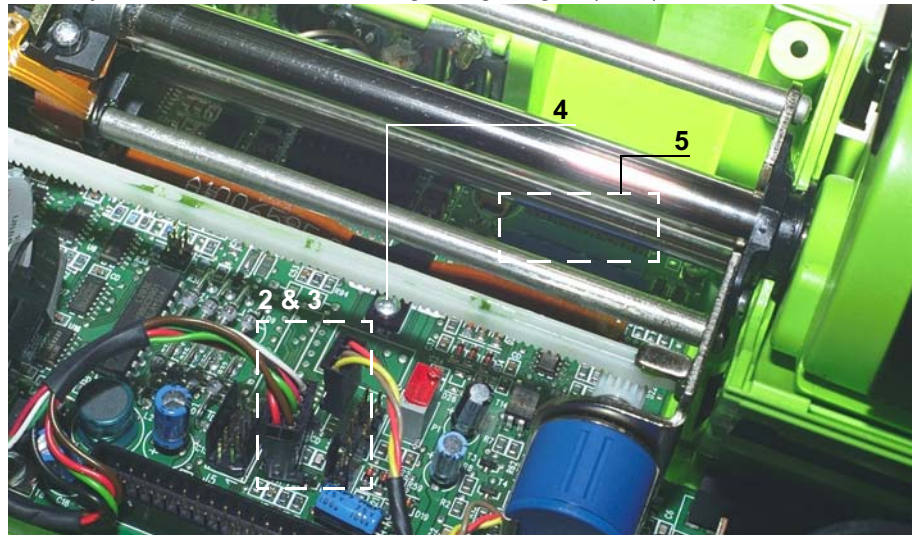

## Reassembly

### Fitting the flexible tongue:

- Remove the clip (ref. 6).
- Stick the flexible tongue (ref. 7) with the adhesive facing the ribbon cable.
- Reposition the clip making sure the ribbon cable and the flexible tongue are centred on the mechanical unit sprocket.
- Lift both ends of the flexible tongue slightly.

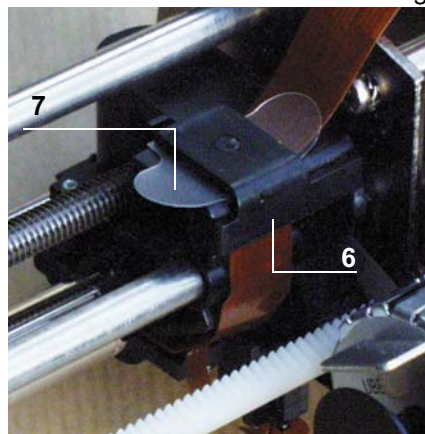

### Fitting the guiding flange:



*There are several types of flange tongues. If you have an older version, replace it with that provided with the kit.*

- Position the new guiding flange (ref. 4) using the two screws.

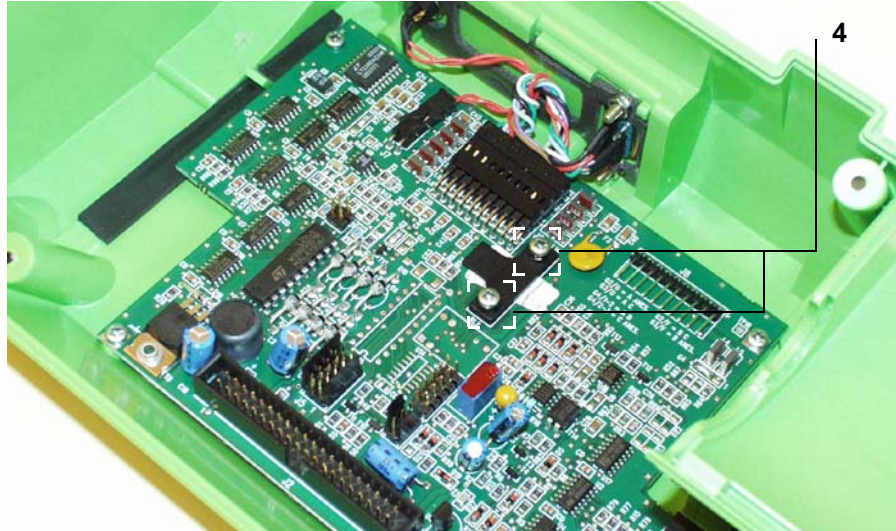

- Disconnect the blue connector (ref 5) from the flat jumper.
- Position the whole mechanical plunger unit making sure the ribbon cable is centred under the flange.
- Perform a few round cycles to check the ribbon cable winds up correctly.
- Connect the black connectors (ref 2 and ref 3).
- Replace the plunger guide.

Carry out the same procedures in reverse to remount the upper case.



*When fitting the upper case, ensure the joint is perfectly positioned in its slot after reassembly.*

Perform the regular servicing tests (see "Regular serving sheet").





## N°12, Procedure: Syringe head detection plunger kit

### Safety:

For safety reasons, the technician should not carry out any maintenance when the device is connected to the 230 V mains supply voltage.

Disconnect the mains power supply cable.

### Equipment required:

- 1 Posidriv Z1 screwdriver.
- 1 2.5 hexagon socket key (2.5).

### Maintenance level:

Level 2, specialised technician (see documentation on biomedical training).

### Procedure:

#### Access

- Turn the **Pilot** over onto the upper case.
- Unscrew the 6 Phillips head screws (ref. 1) located at the bottom of the lower case, which link this to the upper case.
- Keep the **Pilot** assembled and turn it over onto the lower case.
- Remove the upper case making sure the CPU board flat jumper is not accidentally removed in the process.

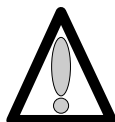

**Hands must not come into contact with the CPU boards.**

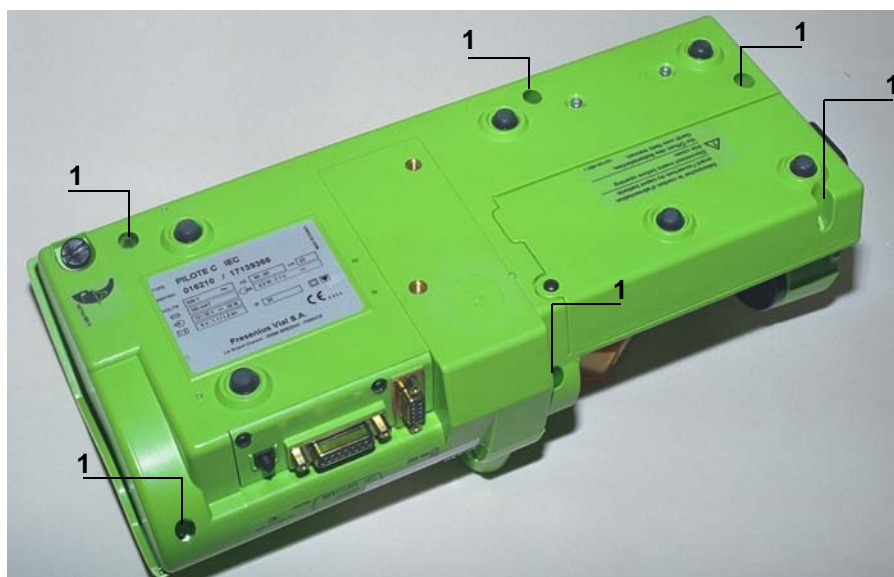

- Press the syringe pump disengagement lever towards the back of the Pilot as far as possible.
- Maintain this position and slide the whole unit to the back right.
- Remove the syringe pump guide.

## Dismounting

- Unscrew the 3 Phillips head screws (ref. 2) located at the bottom of the plunger end shield slots which link this to the plunger cover.

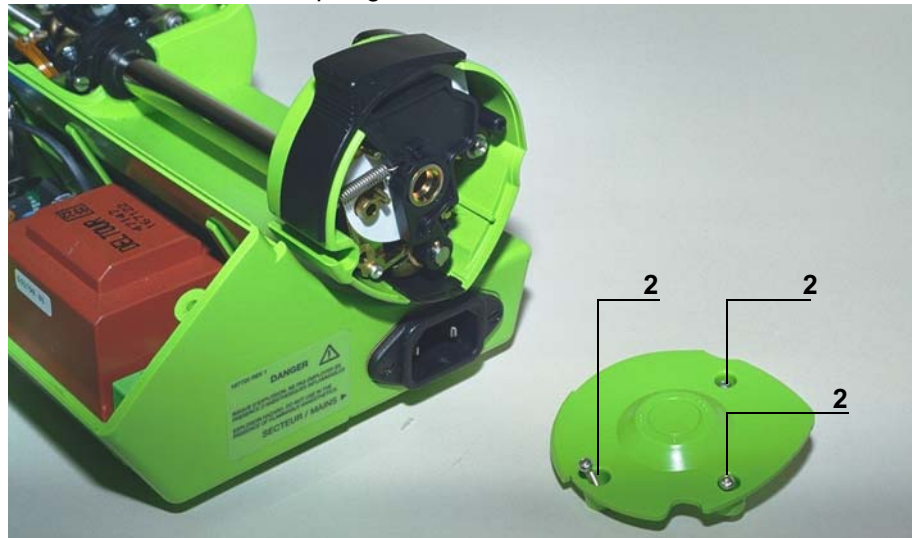

- Remove the plunger end shield, the disengagement lever and its spring as well as the protective plunger film.
- Remove the plunger cover clip.
- Unscrew the 2 Phillips head screws (ref. 3 and 4) which link the plunger support to the plunger cover.
- Unscrew and remove the Phillips head screw and the washer (ref. 5) which hold the anti-siphon cam to the anti-siphon arm.
- Remove the cam/arm unit as well as the plunger cover.
- Remove the bonding pad label (ref. 6).
- Unscrew the six hexagon socket screws (ref. 7) and remove the plunger unit.

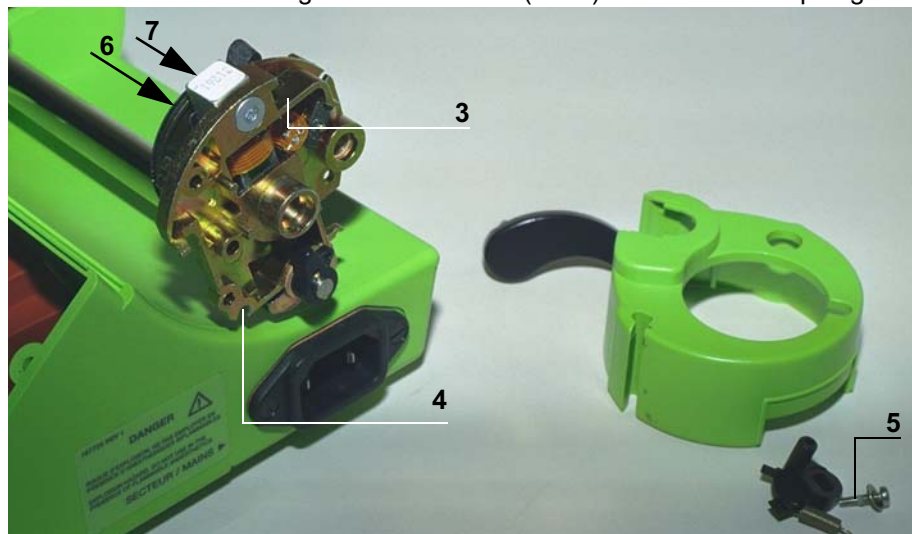

## Remounting

- If necessary, cut the protective flexible ribbon cable label if it protrudes over the edge of the sensor.
- Impregnate with weak loctite and screw the 6 hexagon socket screw (ref. 6) which holds the new bonding pad to the force sensor.
- Break the contact of the bonding pad fixing lugs from the plunger cover.
- Mount the plunger cover onto the plunger support.



*Weak loctite must be used to mount the new arm and the new anti-siphon arm supplied with the kit.*

- Centre the bonding pad in relation to the plunger cover and lock the bonding pad/sensor unit into position on the plunger support.
- Check the free movement of the removable stop plate.

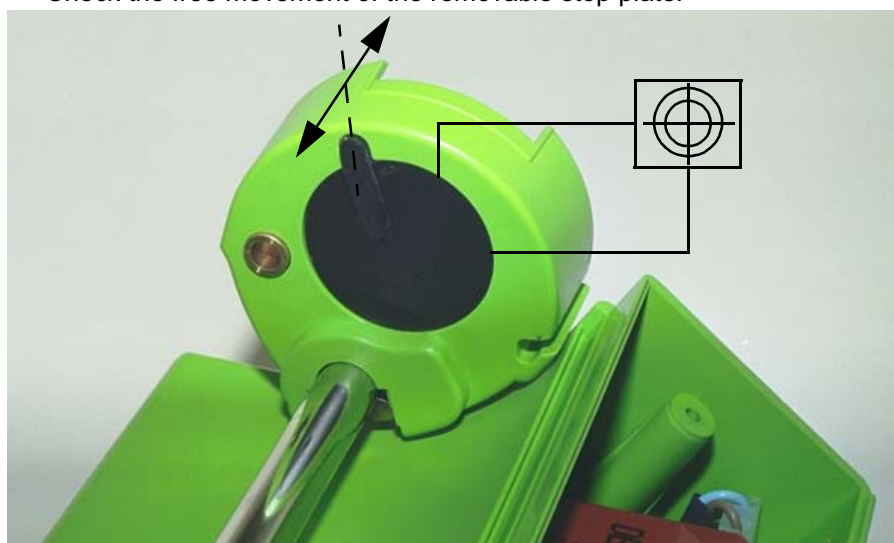

*Do not forget to replace the anti-siphon cam with the new one supplied with the kit.*

- Position and screw the cam/anti-siphon arm unit using the Phillips head screw and the washer (ref. 5).
  - Screw the 2 Phillips head screws (ref. 3 and 4) which link the plunger support to the plunger cover.
  - Position the plunger cover clip.
  - Cover the plunger with the protective film, and mount the disengagement lever and its spring, and screw the plunger end shield back on.
- Carry out the same procedures in reverse to reassemble the unit.



*When fitting the upper case, ensure the joint is perfectly positioned in its slot after reassembly.*

Perform the regular servicing tests (see "Regular servicing sheet").



## N°13, Procedure: Centering ring kit

### Safety:

For safety reasons, the technician should not carry out any maintenance when the device is connected to the 230 V mains supply voltage.

Disconnect the mains power supply cable.

### Equipment required:

- 1 Posidriv Z1 screwdriver.
- 1 cutter.
- GEB type 100% silicone grease.

### Maintenance level:

Level 2, specialised technician (see documentation on biomedical training).

### Procedure:

#### Access

- Turn the **Pilot** over onto the upper case.
- Unscrew the 6 Phillips head screws (ref. 1) located at the bottom of the lower case, which link this to the upper case.
- Keep the **Pilot** assembled and turn it over onto the lower case.
- Remove the upper case making sure the CPU board flat jumper is not accidentally removed in the process.

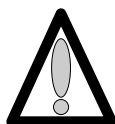

**Hands must not come into contact with the CPU boards.**

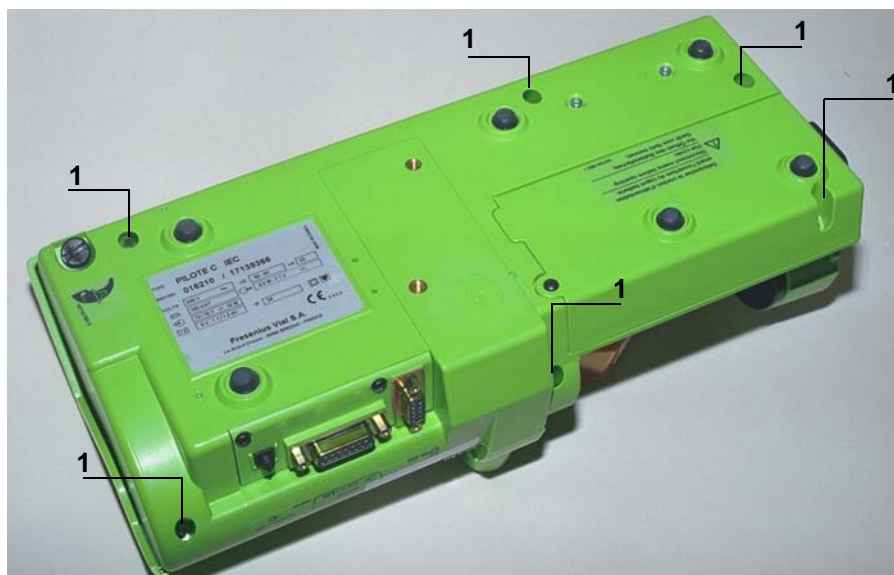

- Press the syringe pump disengagement lever towards the back of the Pilot as far as possible.
- Maintain this position and slide the whole unit to the back left.
- Remove the plunger guide.
- Disconnect the black connectors (ref. 2).
- Unscrew the flat jumper mounting lug (ref. 3) without removing it.
- Remove the mechanical plunger unit from its slot.
- Disconnect the blue connector from the flat jumper (ref. 4).
- Remove the mechanical plunger unit.

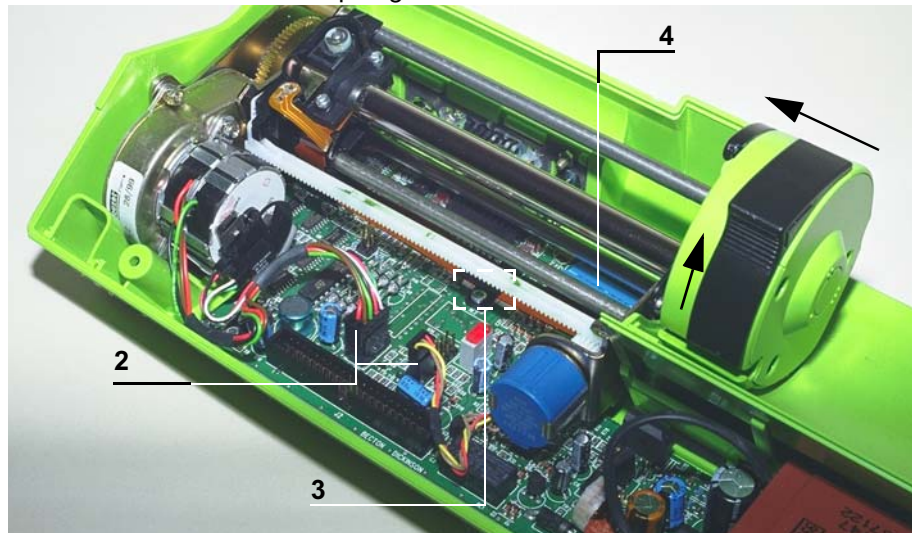

- Press the syringe pump disengagement lever towards the back of the Pilot as far as possible.
- Maintain this position and slide the whole unit to the back right.

## Dismounting

- Unscrew the 2 slotted head screws (ref. 5) which link the centering ring to the mechanical end shield.
- Using the cutter, cut the input bearing and remove it from the plunger tube.

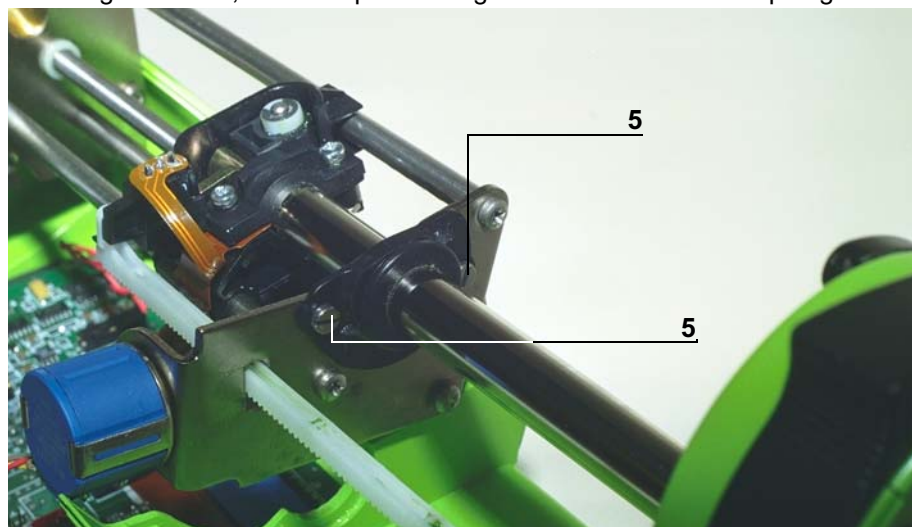

## Remounting

- Mount the new slotted input bearing onto the plunger tube by twisting it.
- Laying it flat on a table, cut the O-ring using a cutter.
- Place the O-ring around the tube.
- Fit the O-ring into the centering ring slot (horizontal cut, so as to avoid lining it up with the centering ring cut).
- Mount the stainless steel slotted plate onto the pin, by twisting it.
- Place the silicone grease cord onto the plate around the passage of the pin.
- Place the plate on the input bearing.
- Position the whole assembly against the mechanical end shield and screw it on using the two slotted screws (ref. 5).
- Check the plunger slides correctly.



*It should slide uniformly across the entire centering ring and slight friction is due to the O-ring scraping against the tube.*

Perform the regular servicing tests (see "Regular servicing sheet").





## N°14, Procedure: Flex circuit and tube kit

### Safety:

For safety reasons, the technician should not carry out any maintenance when the device is connected to the 230 V mains supply voltage.

Disconnect the mains power supply cable.

### Equipment required:

- 1 Posidriv Z1 screwdriver.
- 1 antistatic wriststrap.

### Maintenance level:

Level 2, specialised technician (see documentation on biomedical training).

### Procedure:

#### Access

- Turn the Pilot over onto the upper case.
- Unscrew the 6 Phillips head screws (ref. 1) located at the bottom of the lower case, which link this to the upper case.
- Keep the Pilot assembled and turn it over onto the lower case.
- Remove the upper case making sure the CPU board flat jumper is not accidentally removed in the process.
- Disconnect the CPU board flat jumper.

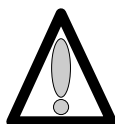

**Hands must not come into contact with the CPU boards.**

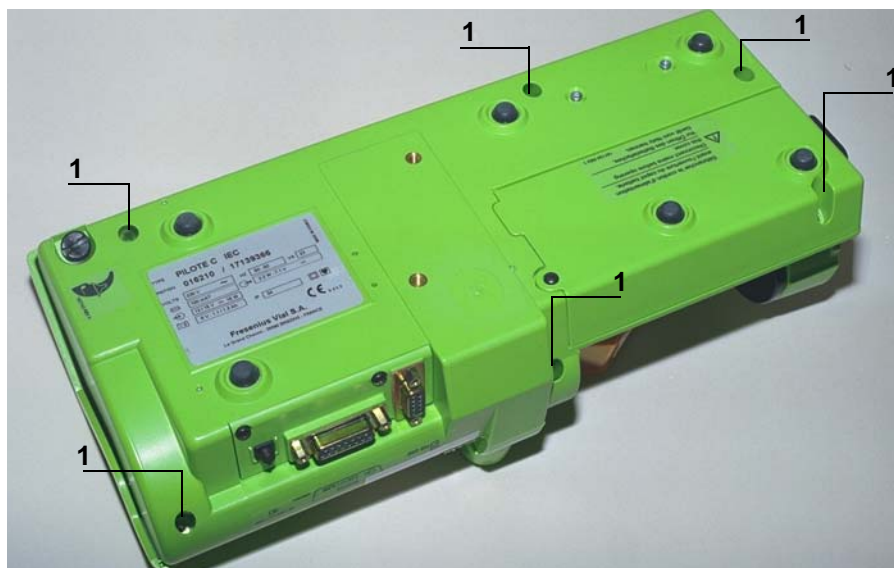

## Dismounting

- Press the syringe pump disengagement lever towards the back of the Pilot as far as possible.
- Maintain this position and slide the whole unit to the back left.
- Remove the plunger guide.
- Disconnect the black connectors (ref. 2).
- Unscrew the flat jumper mounting lug (ref. 3) without removing it.
- Remove the mechanical plunger unit from its slot.
- Disconnect the blue connector from the flat jumper (ref. 4).
- Remove the mechanical plunger unit.

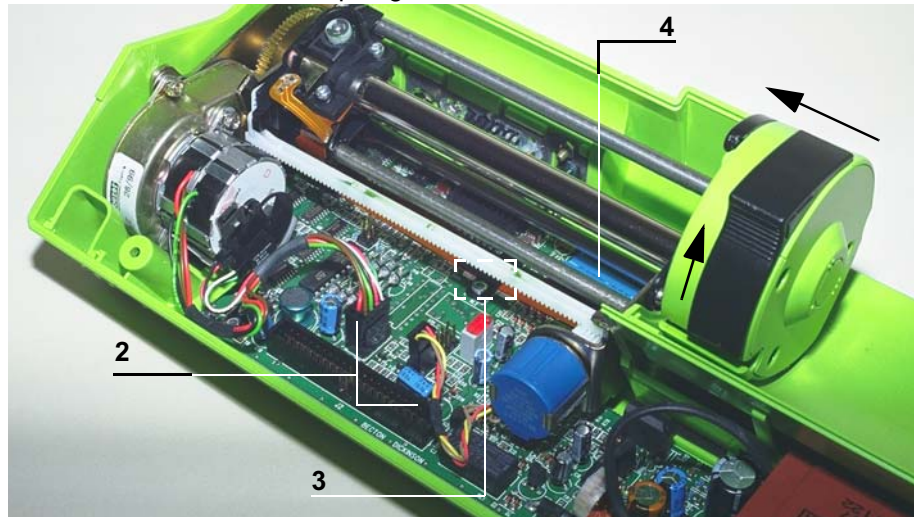

- Press the syringe pump disengagement lever towards the back of the Pilot as far as possible.
- Maintain this position and slide the whole unit to the back right.



*Welding and unwelding operations are carried out using a soldering iron fitted with a tip in good condition, constantly tapered and clean kept.. The temperature of the iron should be between 315°C and 340°C.*

- Unweld the flex circuit (ref. 5) ensuring the disengagement switch is not damaged in the process.
- Unscrew the 2 slotted head screws (ref. 6) which link the centering ring to the mechanical end shield.
- Unscrew the 2 Phillips head screws (ref. 7) which link the centering ring to the mechanical end shield.
- Remove the flex circuit clip (ref. 8).

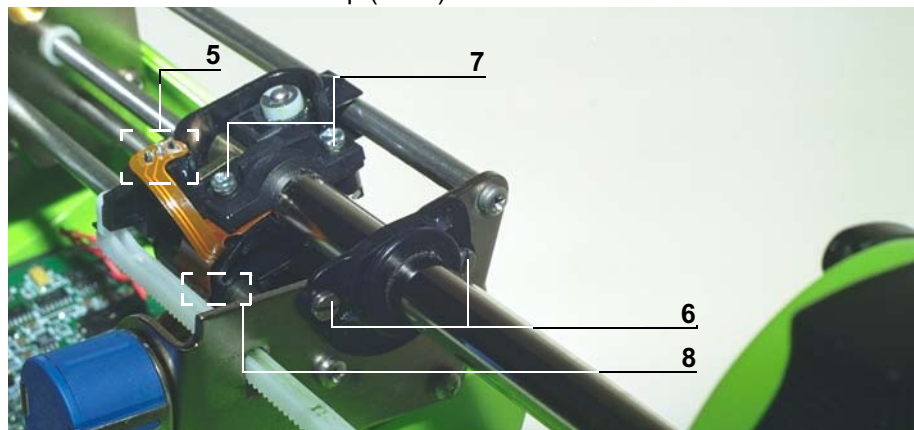

- Unscrew the 3 Phillips head screws (ref. 9) located at the bottom of the plunger end shield which link this to the plunger cover.

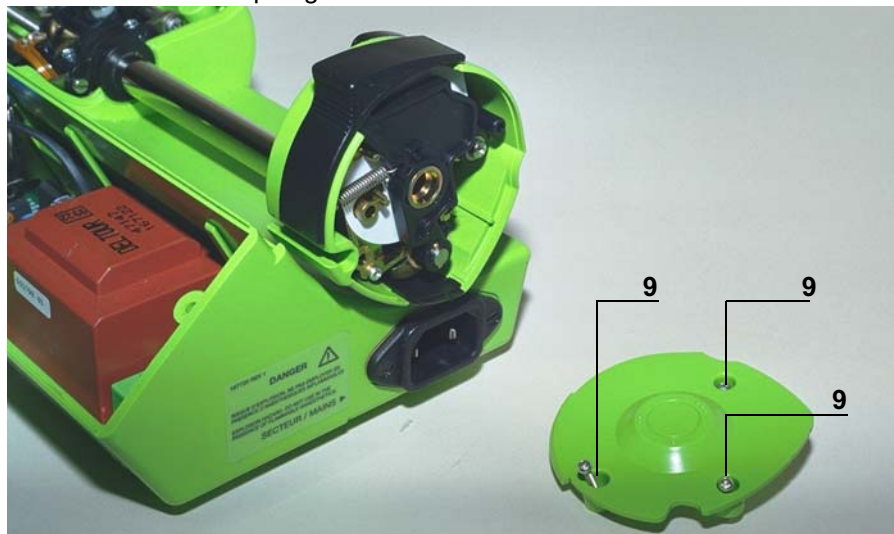

- Remove the plunger end shield, the disengagement lever and its spring (ref. 10) as well as the protective plunger film (ref. 11).

- Remove the plunger cover clip (ref.12).

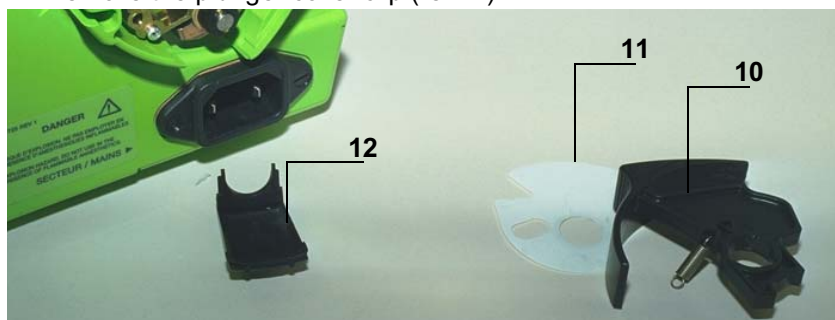

- Unscrew the 2 Phillips head screws (ref. 13 and 14) which link the plunger support to the plunger cover.

- Unscrew and remove the Phillips head screw and the washer (ref. 15) which attach the anti-siphon cam to the anti-siphon arm.

- Remove the cam/arm unit as well as the plunger cover.

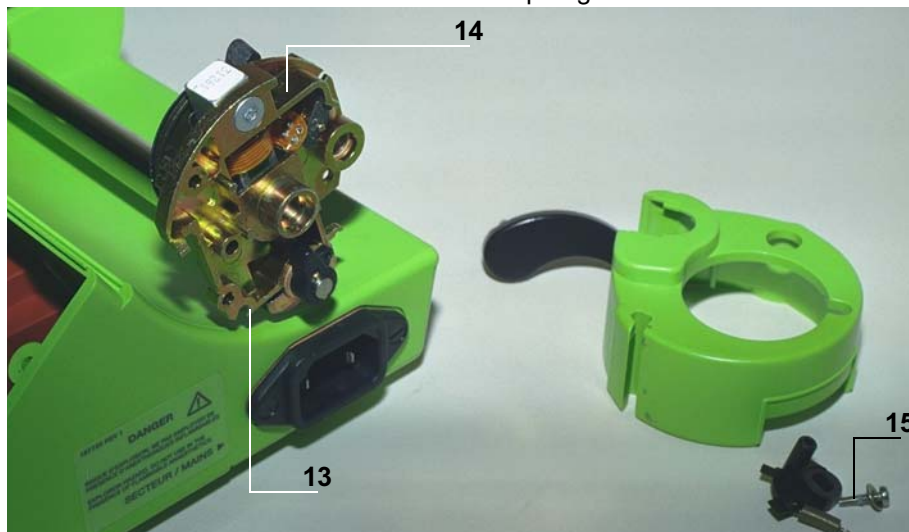

- Unscrew the 6 hexagon socket screws (ref. 16) and remove the force sensor.
- Unscrew the 2 Phillips head screws (ref. 17) which attach the clamping collar to the plunger support.
- Remove the disengagement pin (ref. 18).

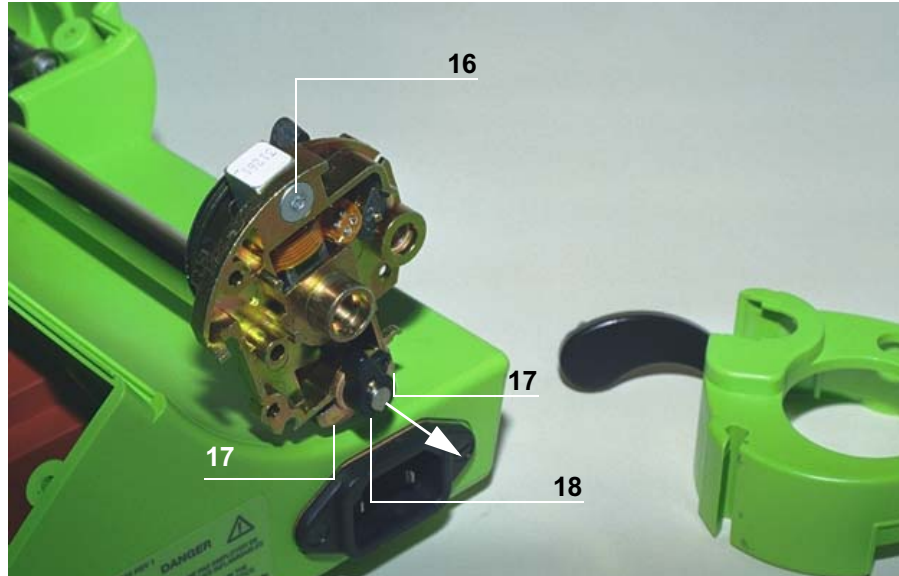

*Welding and unwelding operations are carried out using a soldering iron fitted with a tip in good condition, constantly tapered and clean kept.. The temperature of the iron should be between 315°C and 340°C.*

- Unweld the sensor wires:



*When dismantling the force sensor, ensure the welding blocks are not damaged and the square is not removed in the process.*

- Add more weld to facilitate the unwelding process.
- Heat and pull on the wires one by one.

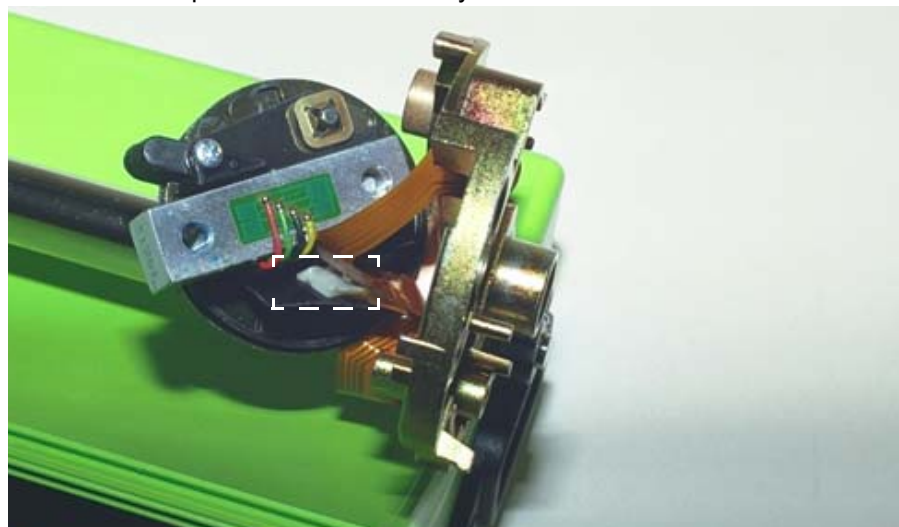

## Remounting

- Remove the sticky tape holding the flex circuit to the tube.
- Cut the part of the flex circuit which corresponds to version A2.
- Weld the disengagement microswitch to the ribbon cable at approximately 1.5 mm without flattening it against this.
- Weld the force sensor wires. Weld the wires to the new sensor, respecting the colour code.
  - Taper the 4 welding wires.
  - Weld the 4 wires.
  - Check that the welding has been carried out correctly. It should not form a ball, but should lie against the length of the wire.

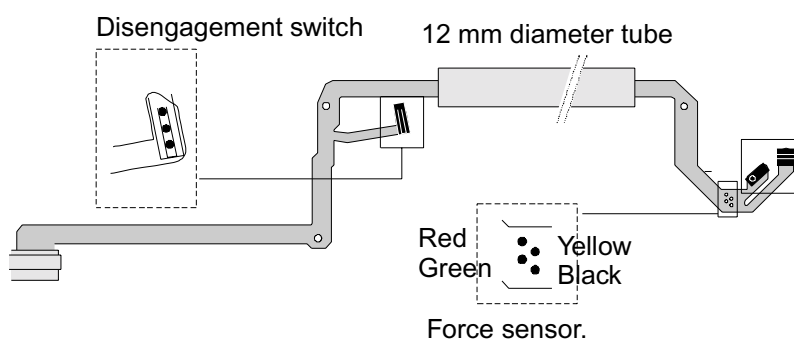

- Slide the excess wire into the force sensor oblong making sure the flex circuit is well-positioned.
- Impregnate with weak loctite and screw the 6 hexagon socket screws (ref. 10) which attach the sensor to the plunger support.

Carry out the same procedures in reverse to remount the unit.



*Do not forget to impregnate the cam/arm clamping screw (rep. 15) with weak loctite.*



*When fitting the upper case, ensure the joint is perfectly positioned in its slot after reassembly.*

Recalibrate the force sensor (see "Calibrations") then carry out the regular servicing tests (see "Regular servicing sheet").



## N°15, Procedure: Upper and lower cases

### Safety:

For safety reasons, the technician should not carry out any maintenance when the device is connected to the 230 V mains supply voltage.

Disconnect the mains power supply cable.

### Equipment required:

- 1 Posidriv Z1 screwdriver.
- 1 antistatic wriststrap.
- 1 soldering iron
- "RADIEL Sn60Pb RI 1" welding wire (cleaning not required for rewelding) or equivalent.

### Maintenance level:

Level 2, specialised technician (see documentation on biomedical training).

### Procedure:

#### Access

- Turn the **Pilot** over onto the upper case.
- Unscrew the 6 Phillips head screws (ref. 1) located at the bottom of the lower case, which link this to the upper case.
- Keep the **Pilot** assembled and turn it over onto the lower case.
- Remove the upper case making sure the CPU board flat jumper is not accidentally removed in the process.
- Disconnect the CPU board flat jumper.

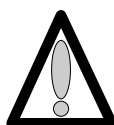

**Hands must not come into contact with the CPU boards.**

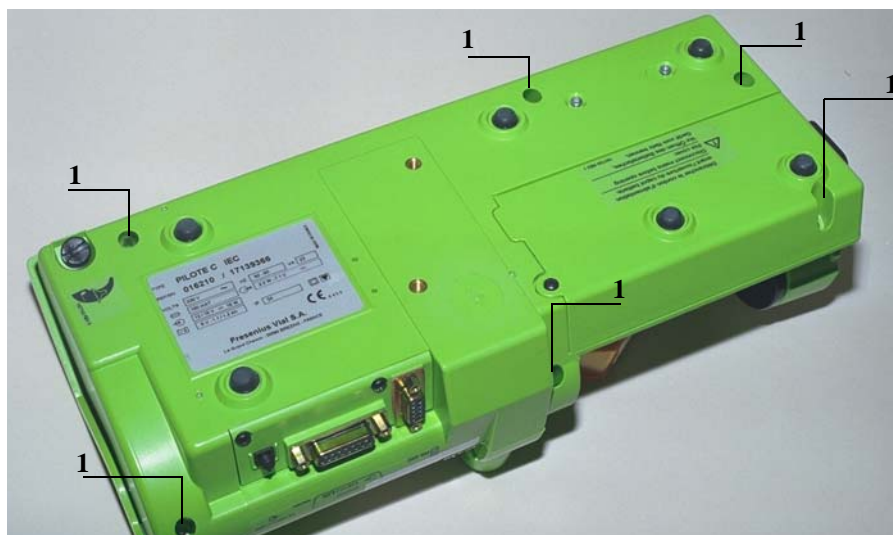

## **Dismounting the upper cover**

- Dismount the central unit and display boards (see corresponding sheet).
- Dismount the syringe clamp (see corresponding sheet).
- Dismount the syringe detection system (see corresponding sheet).

## **Remounting the upper cover**

- Remount the syringe detection system (see corresponding sheet).
- Remount the syringe clamp (see corresponding sheet).
- Remount the central unit and display boards (see corresponding sheet).

## **Dismounting the lower cover**

- Dismount the power supply board (see corresponding sheet).
- Dismount the battery holder (see corresponding sheet).
- Dismount the rear plug support (see corresponding sheet).

## **Remounting the lower cover**

Carry out the remounting procedure in reverse.

Perform the regular servicing tests (see “Regular servicing sheet”).



## N°16, Procedure: Display and central unit boards

### Safety:

For safety reasons, the technician must not intervene when the device is connected to the 230 V mains supply voltage.

Disconnect the mains power supply cable.

### Tools required:

- 1 Posidriv Z1 screwdriver.
- 1 antistatic wriststrap.

### Maintenance level:

Level 2, specialised technician (see documentation on biomedical training).

### Procedure:

#### Access

- Rotate the **Pilot** on the upper case.
- Unscrew the 6 Phillips head screws (ref. 1) Located at the bottom of the lower case, which tighten the latter to the upper case.
- Keep the **Pilot** assembled and turn it over onto the lower case.
- Remove the upper case making sure the CPU board flat jumper is not accidentally removed in the process.
- Disconnect the CPU board flat jumper.

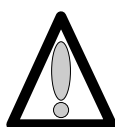

**Hands must not come into contact with the CPU boards.**

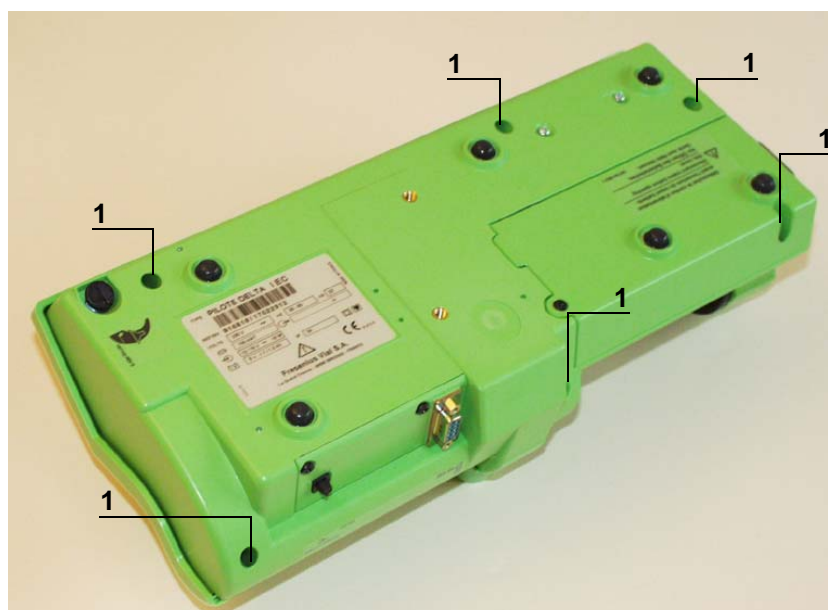

## Dismounting



*When electronic components are handled, it is recommended to wear an antistatic wriststrap linked to ground and to work on an antistatic foam mat.*

- Unscrew the Phillips head screw (ref. 2) Located on the display board, which link this to the upper case.
- Remove the battery insulator (rep.3) located on the right.
- Disconnect the black connector (ref. 4).

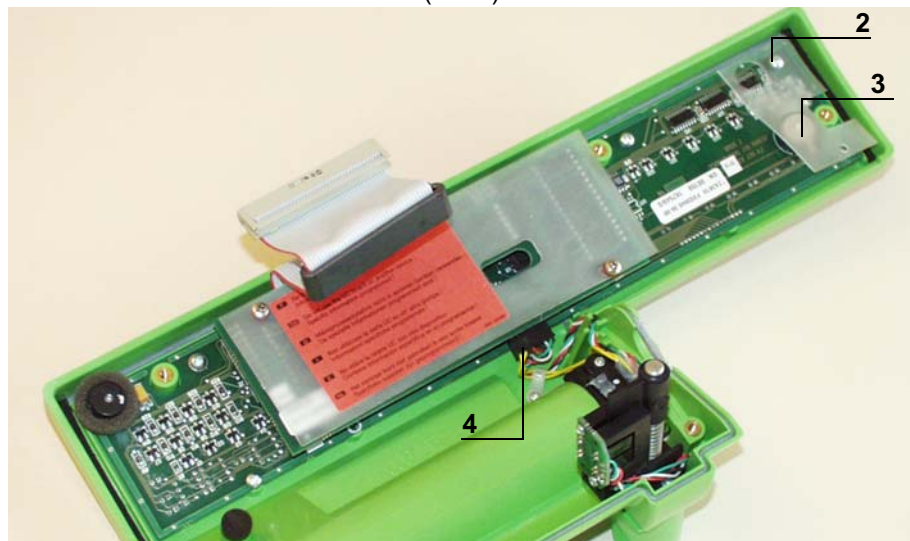

- Lift the batterie fixing tongue and remove.

## Reassembly



*To install a new battery, follow the procedure in reverse and check polarity.*



*When fitting the upper case, ensure the joint is perfectly positioned in its slot after reassembly.*

Recalibrate the **Pilot** (see "Calibrations") then carry out the regular servicing tests (see "Regular servicing sheet").

## 7 Calibration







### 7.1 Calibration procedure



The calibration menu is reserved for authorised personnel only, its access is protected by a secret code.

#### 7.1.1 Calibration access

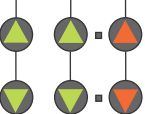
Keyboard description.

Key	Function
	<b>ON</b> , is used to switch the machine on. <b>OFF</b> , is used to switch the machine off when pressed for over three seconds.
	<b>SILENCE ALARME</b> , is used to access the calibration mode.
	<b>VALIDATION</b> , is used to validate a choice.
	<b>BOLUS</b> , is used to access the calibration mode.
	The select keys allow to scroll the figures and letters on the LCD screen, on the units, tens, tens segments etc.
	<b>ENTER / CONFIRM</b> enables the user to validate the test choice or to move from one set of values to another.

#### Activate calibration

- Press the "SILENCE ALARME" and "BOLUS" keys simultaneously.
- 
- Maintain this position while pressing "ON".
- When **E t A L .** is displayed on the screen, release the "SILENCE ALARME" and "PURGE/BOLUS" keys, then validate within three seconds by pressing the "VALIDATION" key.

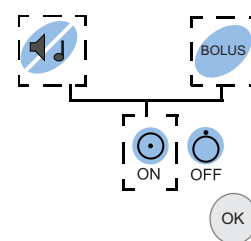

- "000.0" is displayed on the LCD screen.

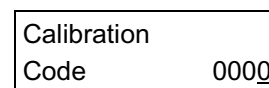

- Type your access code to the calibration mode using the SHIFT CURSOR keys to access the required digit, the "INCREMENTATION ou DECREMENTATION" keys to modify values and the "VALIDATION" to validate.

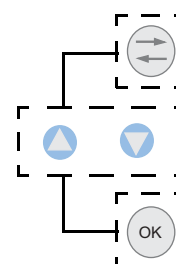

- The equipment starts at calibration **E t A L .4** by default

- Scroll through the different display unit calibration states using the "tens" keys.
- **EtAL.4**: calibration of the 3 battery voltage levels.
- **EtAL.6**: calibration of the position sensor.
- **EtAL.9**: calibration of the force sensor.

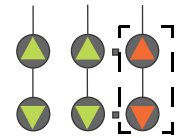

### 7.1.2 EtAL.4 Calibration of the 3 battery voltage levels.

This menu enables the user to store the three Bat1, Bat2 and Bat3 battery voltage values in an EEPROM.

- **EtAL.4**, press "VALIDATION".
  - "Bat 1" is displayed on the LCD screen.
    - Supply the equipment with  $6.3\text{ V} \pm 0.05$  using a stable power supply.
      - ◆ Press "VALIDATION".  
The voltage is read and stored in the EEPROM.
    - Press "VALIDATION".
    - "Bat 2" is displayed on the LCD screen.
    - Supply the equipment with  $5.9\text{ V} \pm 0.05$  using a stabilised power supply.
      - ◆ Press "VALIDATION".  
The voltage is read and stored in the EEPROM.
    - Press "VALIDATION".
    - "Bat.3" is displayed on the LCD screen.
    - Supply the equipment with  $5.7\text{ V} \pm 0.05$  using a stable power supply.
    - Press "VALIDATION".  
The voltage is read and stored in the EEPROM.

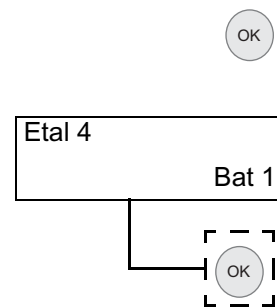

By validating once again, it is possible to select another calibration.

### 7.1.3 EtAL.6 Calibration of the position sensor.

This menu enables users to store both high and low displacement limit values in the EEPROM.

- **EtAL.6**, press "CONFIRM".
  - "HIGH": Place a 115 mm spacer  $\pm 0.05$  ref. T 300940, into the fin groove.
    - ◆ Position the plunger in contact with the spacer.
    - ◆ Keep the plunger disengaged and press "CONFIRM".  
The position value is read and stored in the EEPROM.
  - Press "VALIDATION".
  - "LOW" is displayed on the LCD screen.
  - Place a 20 mm spacer  $\pm 0.05$  ref. T 300775, into the fin groove.
    - ◆ Position the plunger in contact with the spacer.
    - ◆ Keep the plunger disengaged and press "VALIDATION".  
The position value is read and stored in the EEPROM.



Once both high and low values have been stored in the EEPROM, the equipment indicates the number of LSB in decimals between the two measurement points. This value should be  $776 \pm 10$  LSB.



- If the value is out of limits, carry out the calibration procedure once again.
- By validating once again, it is possible to select another calibration.

#### 7.1.4 *E t R L . 9* Calibration of the force sensor.

This menu enables users to store both reference values in the EEPROM.

- *E t R L . 9*, press "VALIDATION". OK
- "0g" is displayed on the LCD screen.
- Set the potentiometer P1 of the power supply board so that the amplitude is  $0.6\text{ V} \pm 0.05\text{ V}$  between J9.4 and the ground J9.1 without applying stress to the plunger.
  - ♦ press "VALIDATION". OK
  - The position value is read and stored in the EEPROM.
- Press "VALIDATION".
- "5kg" is displayed on the LCD screen.
- Apply a force of  $5\text{ Kg} \pm 50\text{ g}$  to the plunger.
  - ♦ press "VALIDATION". The position value is stored in the EEPROM.

By validating once again, it is possible to select another calibration.



## 8 Spare parts catalogue

### 8.1 Upper case

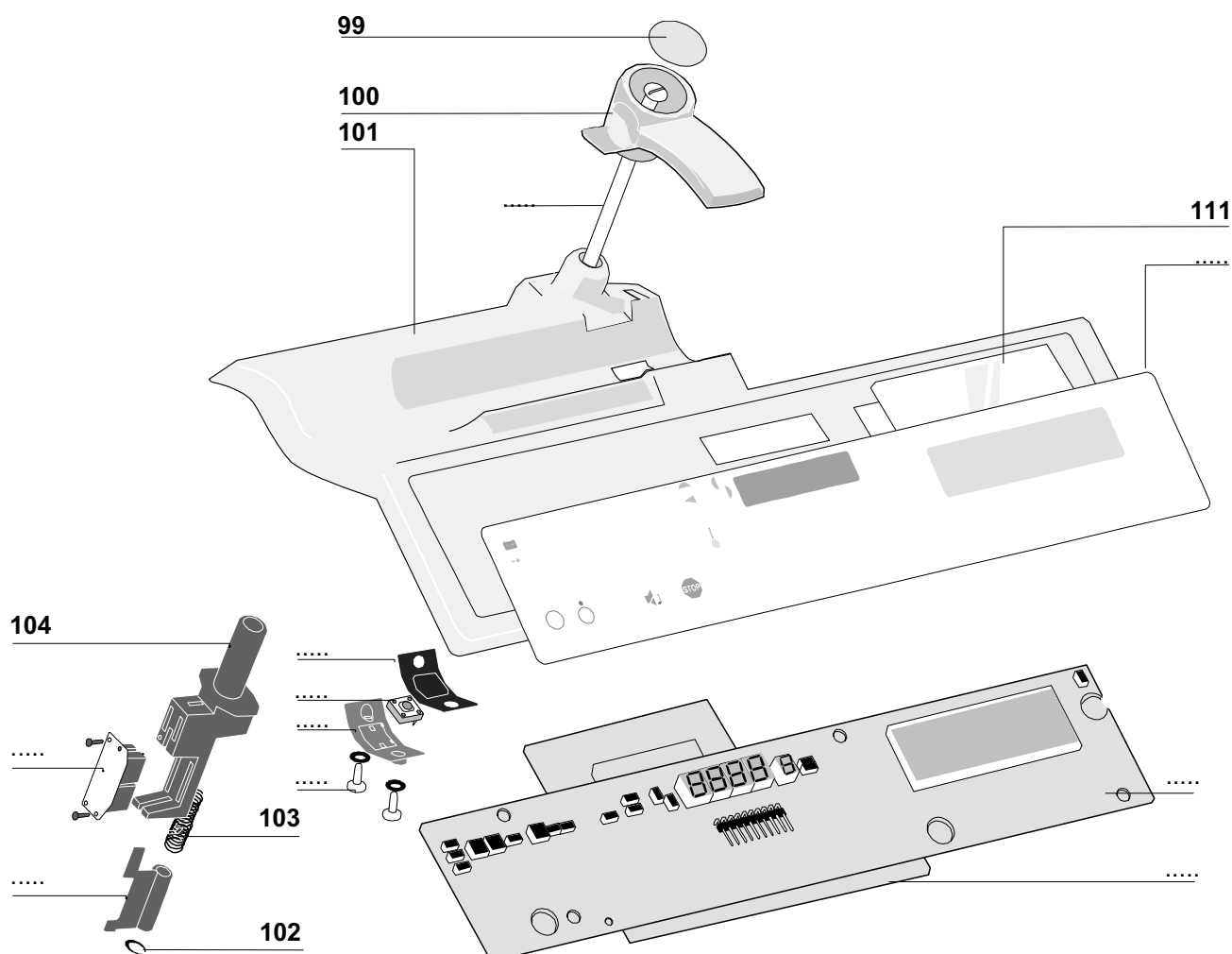

..... : see next page

Mark	Qty	Reference	Name
	1	167627	6 diam injected bumper
	1	199560	Female M3x12 hybrid spacer
	1	167067	PCB 500 protective film
	1	167632	Buzzer foam
	1	167636	Buzzer foam bell
99	1	167744	17.5 diam Pilot label
100	1	167476	20/60cc syringe clamp
101	1	167392	Upper case
102	1	167361	5 diam retaining ring
103	1	167310	Syringe clamp compression spring
104	1	167452	Injected PCB support (opto)
111	1	168343	Pilote An2 Window

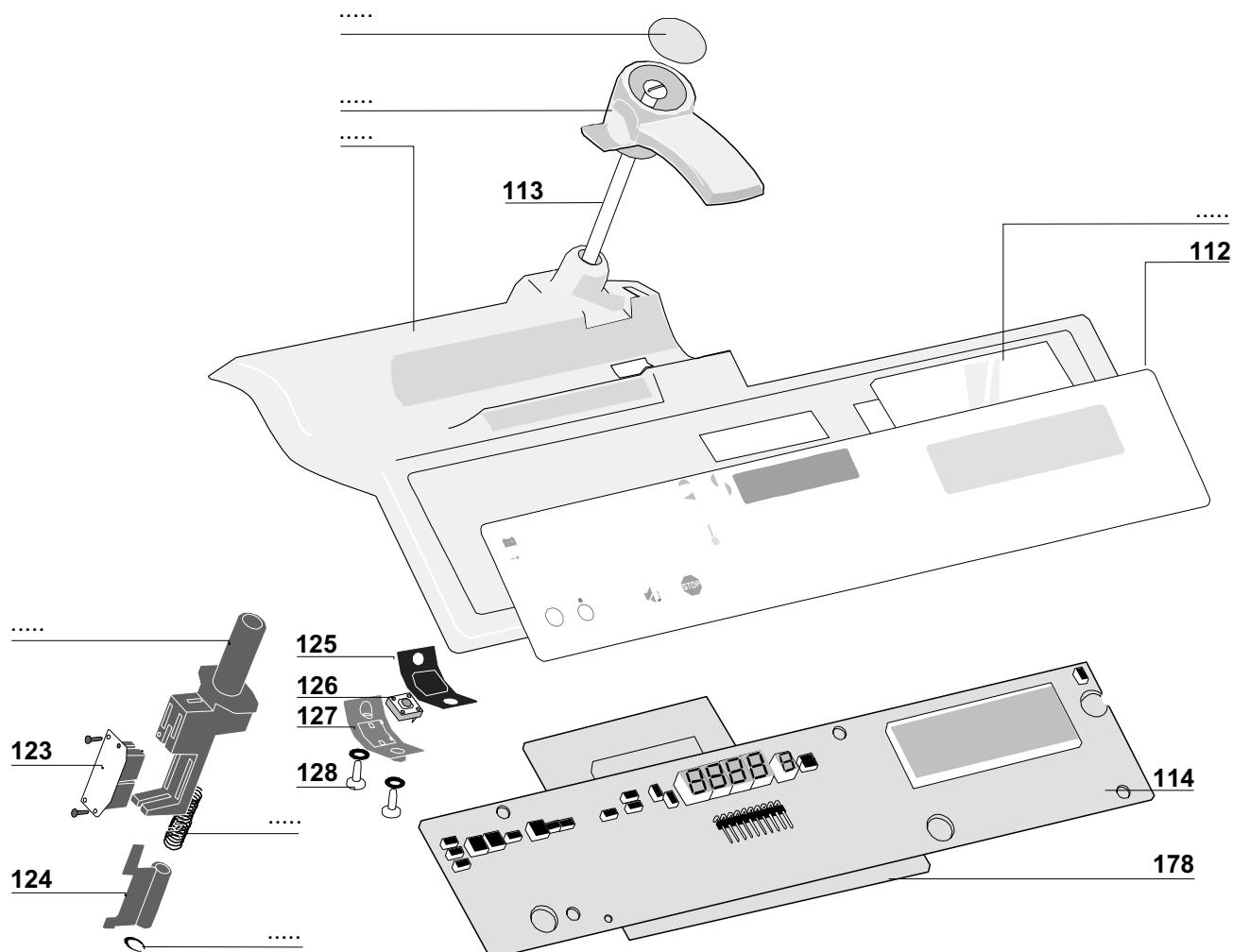

..... : see previous page

Mark	Qty	Reference	Name
112	1	168123	Pilot Delta front panel
113	1	167458	Syringe clamp shaft
114	1	167549	Display board
123	1	167944	HE13 gore pilot opto PCB
124	1	167462	Pilot 20/60 ml obturator
125	1	167372	Fin Pilot Switch Seal
126	1		ALPS SKHCAF switch
127	1		Fin Pilot Switch Support
128	2	199618	Eco-Syn TCB 2.2 x 8 screw
178	1	167548	CPU board

*Mounted on kit 101  
or sub-assembly, ref.167944*



## 8.2 Lower case

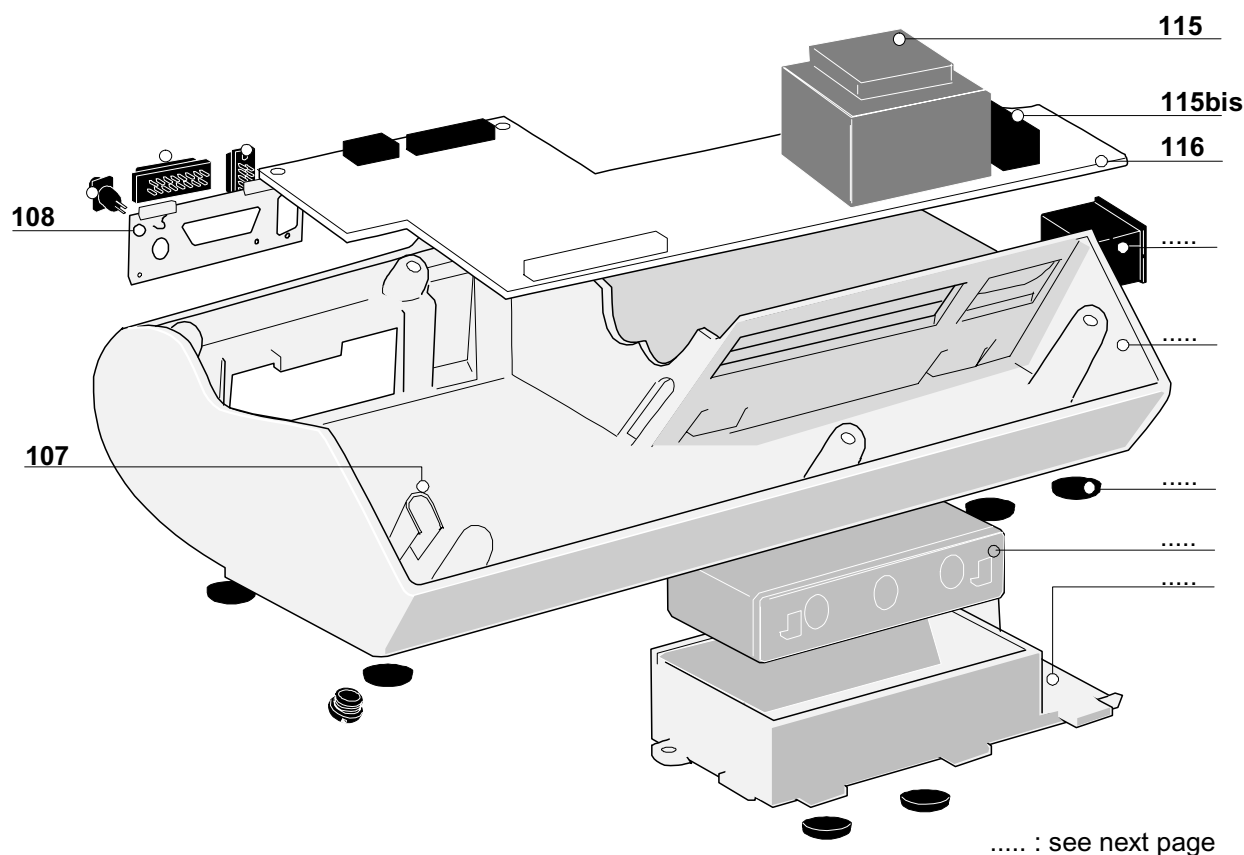

Mark	Qty	Reference	Name
	1	167059	Pilot guide rail
	1	167299	Buzzer adjustment washer
	1	167297	Spring washer
	1	167961	HE13 battery connector
	1	167122	Injected flexible PCB flange
	1	167355	Mains fibre gasket
	1	170416	Mains cord
107	1	167093	Buzzer bell
108	1	167968	Pilot Delta IEC wired plug support
	1	167432	Buzzer adjustment button
115	1	177201	Transformer
115bis	1	170228	Fuse F2
116	1	167536	Power supply board

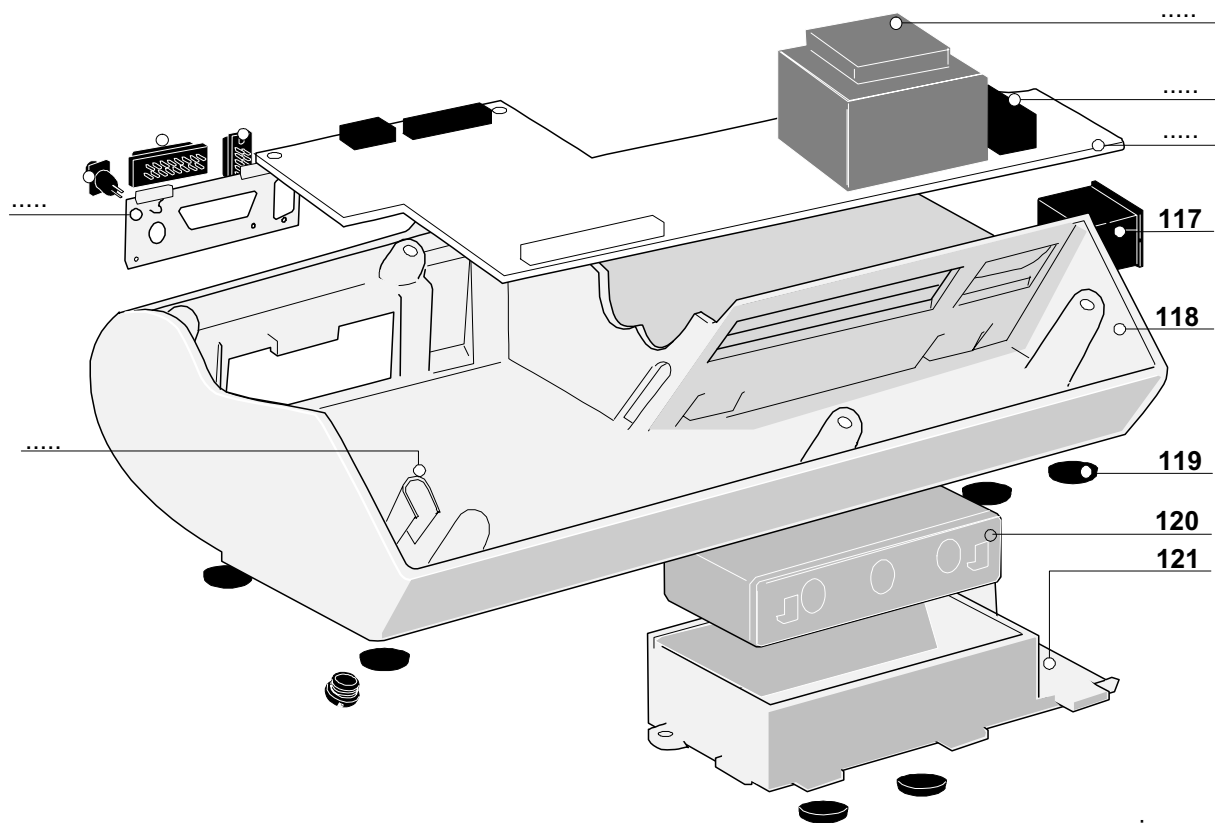

..... : see previous page

Mark	Qty	Reference	Name
117	1	167942	Wired mains socket
118	1		Pilot Delta lower case Kit - contact us
119	6	167249	Black stop piece
120	1	174019	Battery 6 V 1.2/1.3 Ah
121	1	199169	Pilot battery holder

## 8.3 Plunger unit

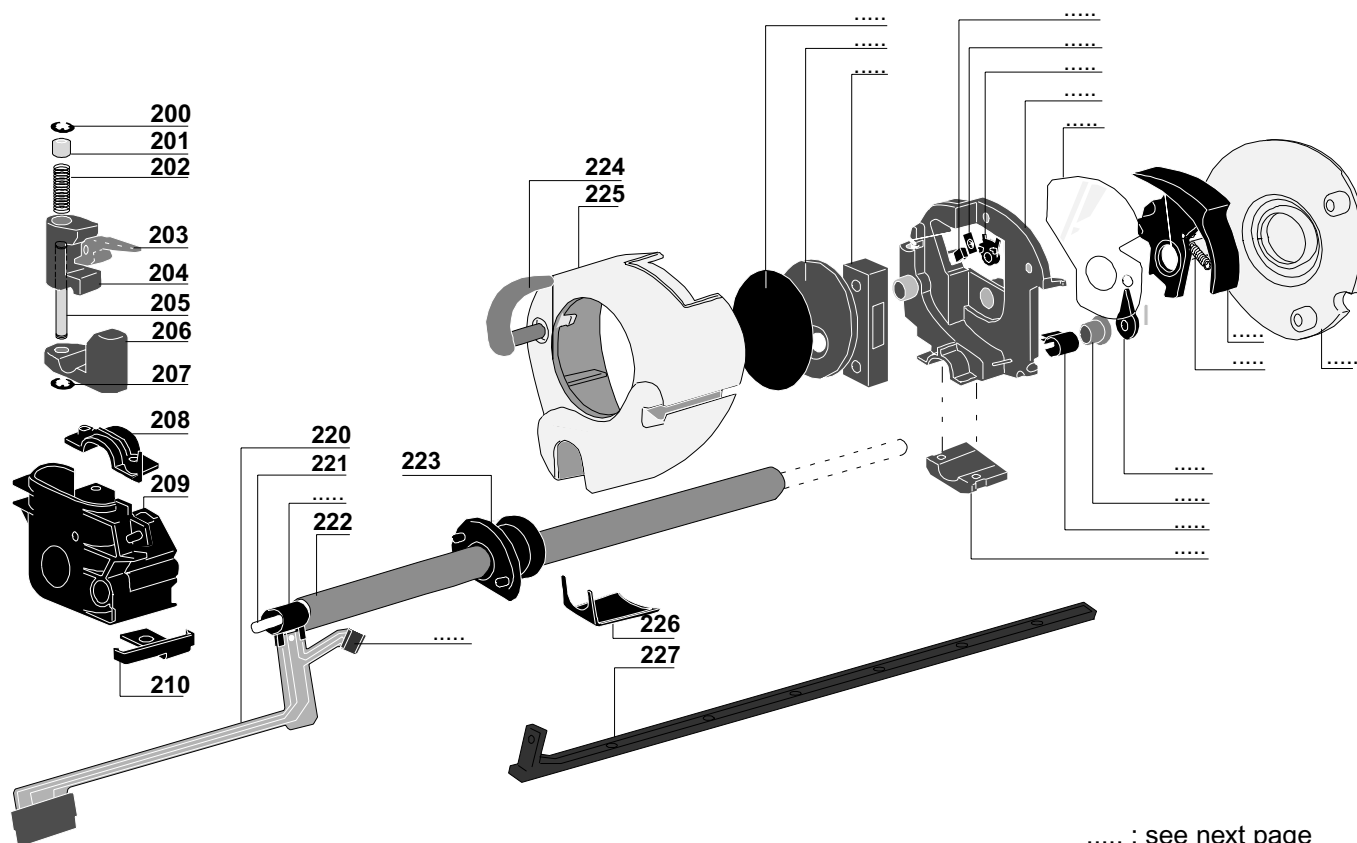

Mark	Qty	Reference	Name
200/207	2	167360	3.5mm diam retaining ring
201	1	167465	Disengagement spring follower
202	1	167469	Disengagement follower
203	1	167460	Injected disengagement cam
204	1	167471	Injected upper mechanism nut
205	1	167464	Disengagement spring shaft
206	1	167472	Injected lower mechanism nut
208	1	167475	Mechanical flange
209	1	167281	Injected slug + mechanical block
210	1	167275	Flexible PCB clip
220	1	167271	Included in 273 kit
221	1	167241	Full disengagement shaft
222	1	167292	Included in 273 kit
223	1	167403	Slotted injected input bearing
	1	177203	O-ring (to put in the bearing)
	1	177204	Stainless steel plate (to be mounted between the bearing and the end shield)
224	1	167291	Pilot anti-siphon arm
225	1	167382	Plunger cover, green, Pilots Delta IEC and Delta M IEC
226	1	167259	Plunger cover clip
227	1	167442	Injected M 0.5 rack

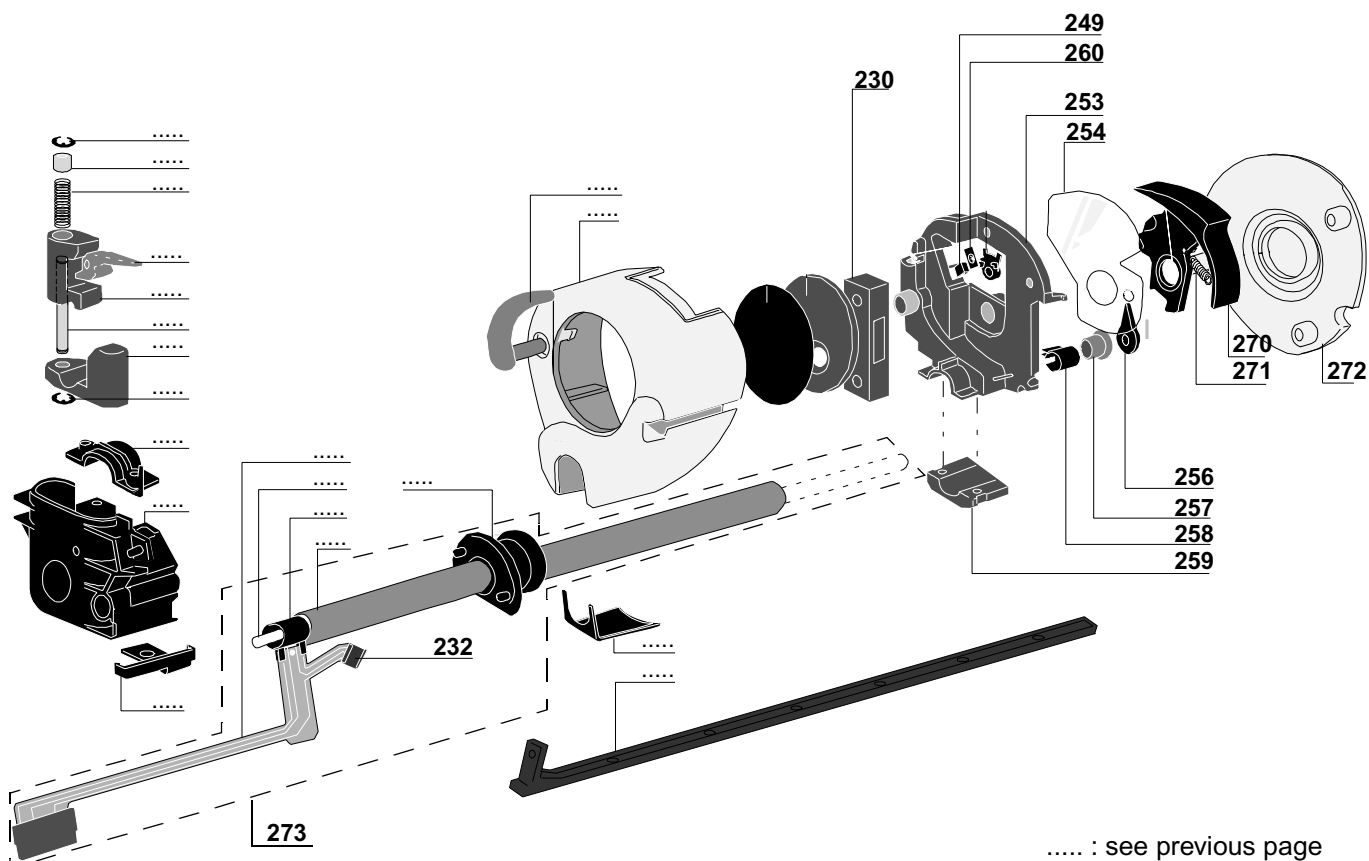

..... : see previous page

Mark	Qty	Reference	Name
230	1	167132	Force sensor.
232	1	173408	OMRON micro-switch
249	1	162311	Photo switch (type RP I 131)
253	1	167288	Reduced play C D plunger support
254	1	167497	Protective plunger film
256	1	168231	Disengagement finger
257	1	167487	Sintered disengagement shaft bearing
258	2	167298	Injected flexible PCB protector
259	1	167272	Injected clamping collar
260	1	190714	Retaining ring
	1	167264	Anti-siphon spring
270	1	167260	Disengagement lever, Pilots Delta IEC
271	1	167245	Disengagement lever spring
272	1	167056	Plunger end shield, Pilots Delta IEC
273	1	199103	Flexible circuit + tube kit

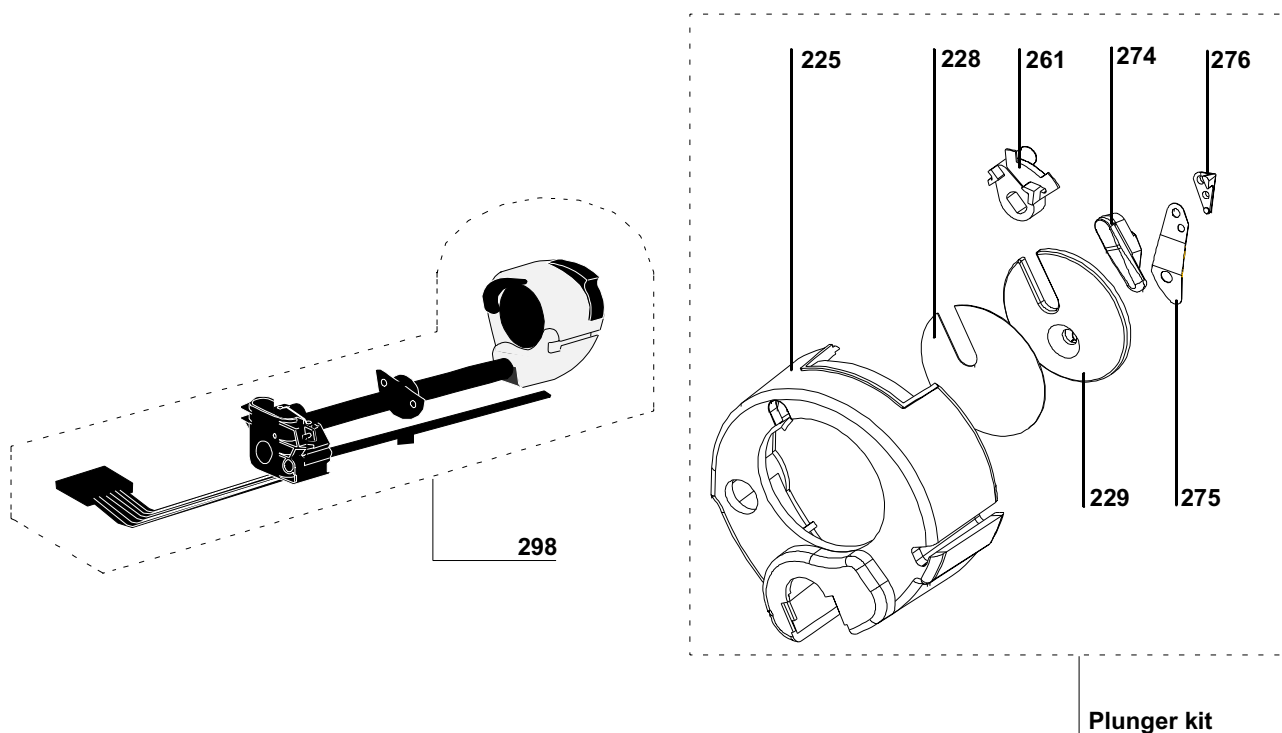

Mark	Qty	Reference	Name	
225	1		Pilot plunger cover	
228	1		36 diam protective label 36	
229			Bonding pad	
229	1		Inj C bonding pad	Included in the plunger 298 kit + 199253
261	1		Anti-siphon cam	
274	1		Pil plunger removable bumper	
275	1		Pil plunger spring leaf	
276	1		Plate b	
298	1	199136	Mechanical kit	



## 8.4 Mechanical gear base

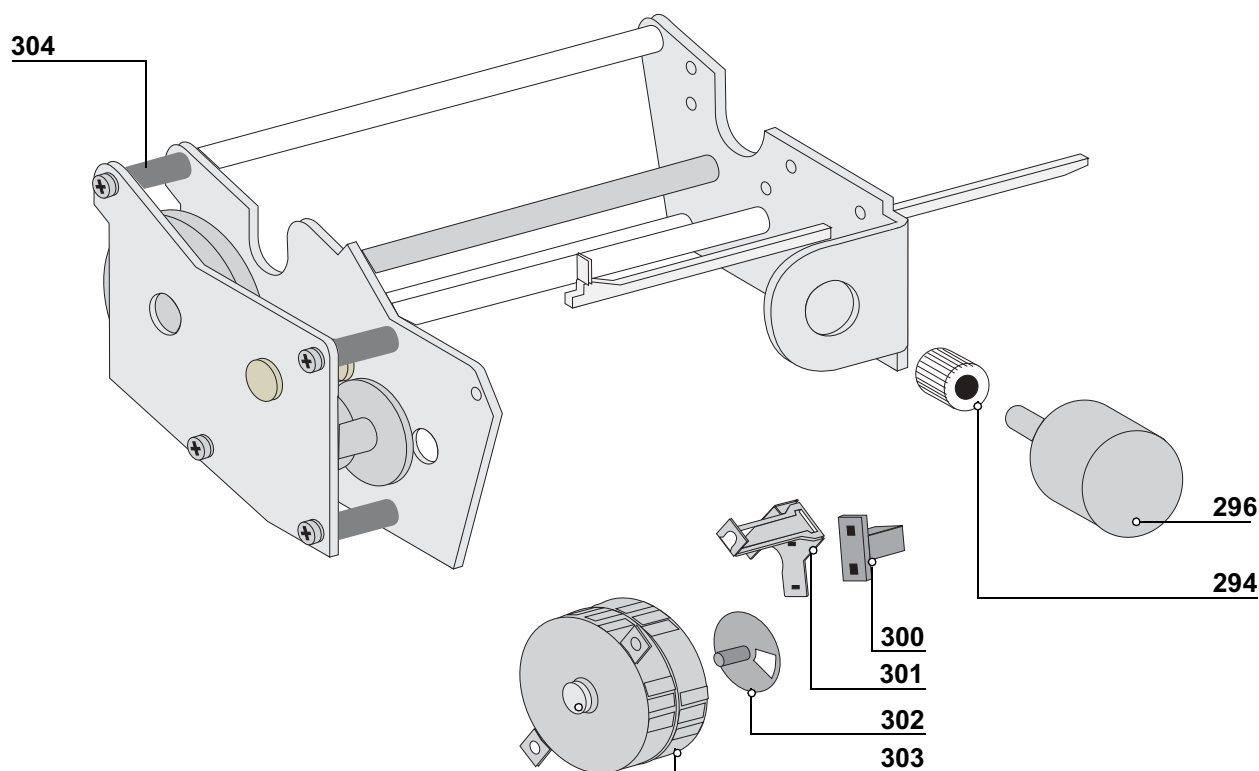

Mark	Qty	Reference	Name
294	1	167443	Injected M5 pinion
296	1	167963	Cabled position sensor 2
300	1	167128	Rotation photo switch
301	1	168401	Opto support
302	1	167111	Motor rotation disk
304	1	167101	Reducer frame + end shields + rods
300/302/ 303	1	167965	2-ph motor + HE13 opto







## Useful addresses

### SALES DEPARTMENT

**Fresenius Vial**  
Le Grand Chemin, 38590 Brézins

#### CUSTOMER SERVICE

Tel.: 00 33 (0) 4 76 67 10  
81  
or 00 33 (0) 4 76 67 10  
54  
or 00 33 (0) 4 76 67 11  
08  
Fax: 00 33 (0) 4 76 67 11  
34

---

#### SALES MANAGEMENT

Tel.: 00 33 (0) 4 76 67 10  
81  
Fax: 00 33 (0) 4 76 67 11  
34

### TRAINING DEPARTMENT

**Fresenius Vial**  
Le Grand Chemin, 38590 Brézins

Tel.: 04 76 67 10 76  
Fax: 04 76 67 11 22

### AFTER SALES SERVICE

FRANCE

After Sales Service Division GRENOBLE  
**Fresenius Vial** Le Grand Chemin, 38590 Brézins  
FRANCE

Tel.: 04 76 67 10 34  
Fax: 04 76 67 11 22

BELGIUM

**FRESENIUS VIAL** NV/SA  
Vial Médical Division  
Molenberglei 7  
2627 Schelle  
BELGIUM

Tel.: 32/388.07307  
Fax: 32/388.05007

GERMANY

**FRESENIUS MCM**  
AM-Neuen Berg  
63749 ALZENAU  
GERMANY

---

This document may contain errors or typing mistakes.  
Modifications may be made in future revisions.  
COPYRIGHT © 1998, **Fresenius Vial S.A.**

This document may not be reproduced in part or in whole without the written permission of  
**Fresenius Vial S.A.**

**Fresenius Vial S.A.** Headquarters: Le Grand Chemin - 38590 Brézins (FRANCE)  
Public Company with board of directors and advisory council, and with a capital of  
90,128,000FF  
SIREN Grenoble B 408 720 282.  
Design and development: SONOVISION-ITEP