

PILOT C, CE2



Series N° 16530596 to



1 Overview	7
1.1 General	7
1.2 Overview diagram	8
1.3 Precautions to be taken before use.....	9
1.4 Internal safety features	9
1.5 Technical characteristics	9
1.5.1 Electrical specifications	9
1.5.2 Electronic specifications	9
1.5.3 Mechanical specifications	9
1.5.4 Conformity, standards	10
2 Description and operation	11
2.1 Physical description	11
2.1.1 The display board and the front panel.....	12
2.1.2 CPU board	14
2.1.3 The power supply board and the battery.....	17
2.1.4 Mechanical gear box unit	20
2.1.5 Mechanical plunger unit	20
2.2 Functional description.....	21
2.2.1 Syringe control and maintenance assembly	21
2.2.2 Motorisation assembly	21
2.2.3 External connection sub-assembly	21
3 Description of the menus	23
3.1 Pressure parameter configuration menu	23
3.1.1 Menu access	23
3.1.2 <i>PrE 1</i> , configuration of the occlusion alarm.....	24
3.1.3 <i>PrE 2</i> , pressure limit configuration	25
3.1.4 <i>PrE 3</i> , configuration of the pressure drop detection threshold.....	26
3.1.5 <i>PrE 4</i> , configuration of the pressure display mode	26
3.2 Configuration menu of the current operation parameters	27
3.2.1 Menu access	27
3.2.2 <i>PAR 1</i> , configuration of the memorisation type	28
3.2.3 <i>PAR 2</i> , configuration of the syringe selection type.....	29
3.2.4 <i>PAR 3</i> , configuration of the maximum flow rate that may be selected on the keyboard	29
3.2.5 <i>PAR 4</i> , configuration of the list of syringes that may be selected.....	30
3.2.6 <i>PAR 5</i> , configuration of the compulsory priming	31
3.2.7 <i>PAR 6</i> , configuration of the rapid infusion start-up.....	31
3.2.8 <i>PAR 7</i> , configuration of the KVO flow rate	32
3.2.9 <i>PAR 9</i> , configuration of the RS232 communication speed.....	32
3.2.10 <i>PAR A</i> , configuration of the empty syringe mode	33
3.2.11 <i>PAR b</i> , configuration of the frequency of preventive checks	33
3.2.12 <i>PAR C</i> , configuration of the drug display mode	34
3.2.13 <i>PAR d</i> , configuration of the fin detection mode	34

3.2.14	<i>P R r F</i> , configuration of the bolus flow memorisation mode	35
3.2.15	<i>P R r G</i> , configuration of the drugs list	36
3.2.16	<i>P R r U</i> , configuration of the mains disconnection signal.....	36
3.2.17	Typical syringe/details correspondence table	37
3.3	Calibration menu.....	39
3.4	ASS test menu.....	41
4	Preventive maintenance.....	43
4.1	Recommendations.....	43
4.2	Maintenance schedule.....	43
4.2.1	Use beyond the framework of the departmental order	43
4.2.2	Use within the framework of the departmental order	43
4.3	Checks	45
4.3.1	Test access	45
4.3.2	Visual check	45
4.3.3	Running time and servicing inspection date.....	46
4.3.4	Indicator lights check.....	46
4.3.5	Keyboard check	47
4.3.6	Battery voltage check.....	48
4.3.7	Checking the last 10 alarms	48
4.3.8	Total running time check	49
4.3.9	TTL serial link test	49
4.3.10	RS 232 serial link check.....	50
4.3.11	Checking the force sensor	50
4.3.12	Checking the software version	50
4.3.13	Checking the ADC.....	51
4.3.14	Checking the position sensor	51
4.3.15	Buzzer test	52
4.3.16	Display of the calibration values.....	52
4.3.17	Checking the syringe clamp	52
4.3.18	Checking the syringe group number	53
4.3.19	Checking the list of syringes	53
4.3.20	Checking the disengagement system	53
4.3.21	Checking the fin detection system	53
4.3.22	Checking the anti-siphon arm	54
4.3.23	Checking the backpressure.....	55
4.3.24	Checking the end of infusion pre-alarm	56
4.3.25	Checking the limit volume programming	57
4.3.26	Checking the linearity.....	57
4.3.27	Checking the list of syringes	58
4.3.28	Checking mains/battery operation.....	58
4.3.29	Battery autonomy test	59
4.3.30	Continuity test	59
4.3.31	Regular inspection sheet.....	61
4.4	Flow rate control.....	63
4.4.1	Measurement with a computer	63
4.4.2	Measurement with scales.....	65

4.4.3	Measurement using a test tube.....	67
4.5	Cleaning and disinfection.....	69
4.6	Storage	70
5	Diagnosis	71
5.1	Troubleshooting	71
5.2	Error messages	73
6	Operation sheets	75
N°1,	Procedure: Display and central unit boards	77
N°2,	Procedure: Syringe clamp	79
N°3,	Procedure: Syringe detection system	81
N°4,	Procedure: Motor + Opto + Disk	87
N°5,	Procedure: Pressure sensor.....	89
N°6,	Procedure: Plunger advance control potentiometer	93
N°7,	Procedure: Plunger cover and/or disengagement lever + anti-siphon arm.....	95
N°8,	Procedure: Power supply board.....	97
N°9,	Procedure: Battery holder and battery	99
N°10,	Procedure: Rear plug support	101
N°11,	Procedure: Ribbon cable winding kit.....	103
N°12,	Procedure: Syringe head detection plunger kit	107
N°13,	Procedure: Centering ring kit	111
N°14,	Procedure: Flex circuit and tube kit.....	115
N°15,	Procedure: Upper and lower cases.....	121
7	Calibration.....	125
7.1	Calibration procedure	125
7.1.1	Calibration access.....	125
7.1.2	<i>E t R.4</i> Calibration of the 3 battery voltage levels.....	126
7.1.3	<i>E t R.5</i> Calibration of the position sensor.	126
7.1.4	<i>E t R.9</i> Calibration of the force sensor.....	127
8	Spare parts catalogue	129
8.1	Upper case	129
8.2	Lower case.....	133
8.3	Plunger unit	135
8.4	Mechanical gear box	139
8.5	Labels	141

1 Overview

1.1 General

The **Pilot C** is a syringe pump intended for the infusion of low-flow intravenous agents with accurate control of the infusion pressure. Electronic management of the infusion pressure which is permanently displayed allows users to obtain very short occlusion detection delays. A pre-warning occlusion alarm and a pressure drop alarm detecting any possible disconnection ensure infusion continuity is maintained.

The **Pilot C**, with a flow range from 0,1 to 800 ml/hr, is the ideal instrument for intensive care and neonatology units .

1.2 Overview diagram

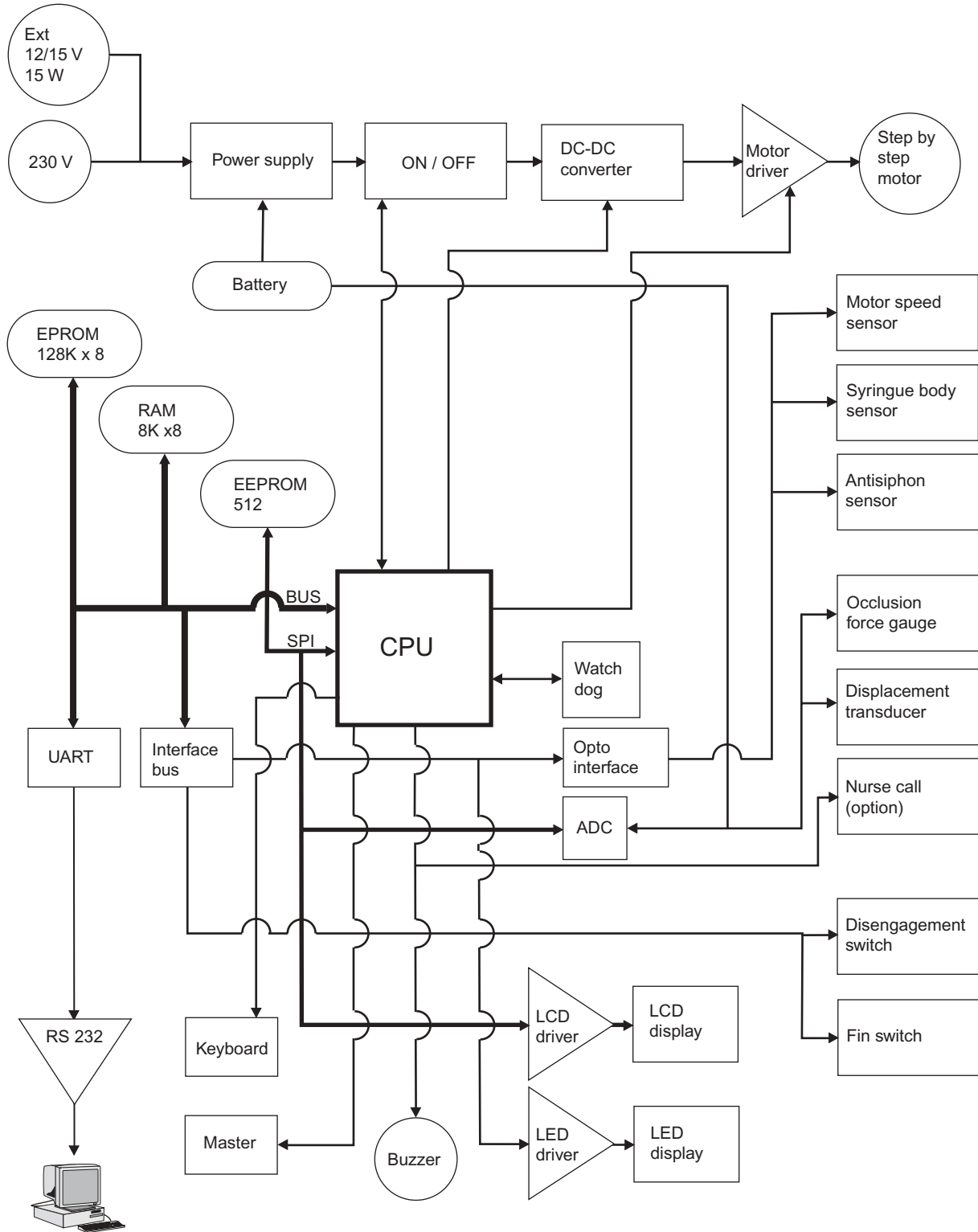

1.3 Precautions to be taken before use

The symbol  in the concise instructions guide of the device recommends that the operator's guide should be read completely in accordance with standard EN 60601-1.

Fresenius Vial may in no case be held responsible for medical problems or any other problems resulting from inadequate use of the equipment.

Refer to the User's instructions for further details.

1.4 Internal safety features

As soon as it is switched ON, the device activates a continuous function inspection system. Any internal failure or any problem related to the operating procedure in progress is detected immediately. Nevertheless, abnormal operation of the equipment with no obvious cause must always be reported to the qualified technicians in your establishment or our After Sales service.

In case of single fault condition, an alarm is activated for any flow rate deviation of $\pm 5\%$ in comparison with the normal flow rate.

A second check activates an alarm in the event of deviation of 1 ml in comparison with the anticipated infused volume, or if a flow rate deviation of $\pm 20\%$ is identified. The alarm is triggered by the most rapidly detected deviation.

The **Pilot** is fitted with an internal battery to continue operation in the event of a power cut. Furthermore, a safety fuse protects the mains from further disturbance.

1.5 Technical characteristics

1.5.1 Electrical specifications

- Power supply: 230 V - 50-60 Hz.
- Max. consumption: 23 VA.
- Fuse F2: 100 mAT 250 V IEC 127.
- Battery: 6 V - 1,2 Ah.
- External power supply: 12 - 15 V DC -15 W.

1.5.2 Electronic specifications

The **Pilot** syringe pump is fitted with 3 circuit boards:

- Motor power supply and control board.
- CPU board.
- Keyboard display board.

1.5.3 Mechanical specifications

- Overall dimensions H x W x D: 120 x 330 x 155 mm.
- Weight: approximately 2,2 kg.

1.5.4 Conformity, standards

- In compliance with the European Directive 93/42 EEC related to Medical Equipment: CE0459.
- In compliance with the European Directive 89/336 EEC: Electromagnetic compatibility.
- Compliant with the standards EN 60601.1 and PrEN60601-2-24.
- Protection against leakage currents: CF type.
- Protection against electric shock: Class II.
- Protection against splashing liquid: IP34.

2 Description and operation

2.1 Physical description

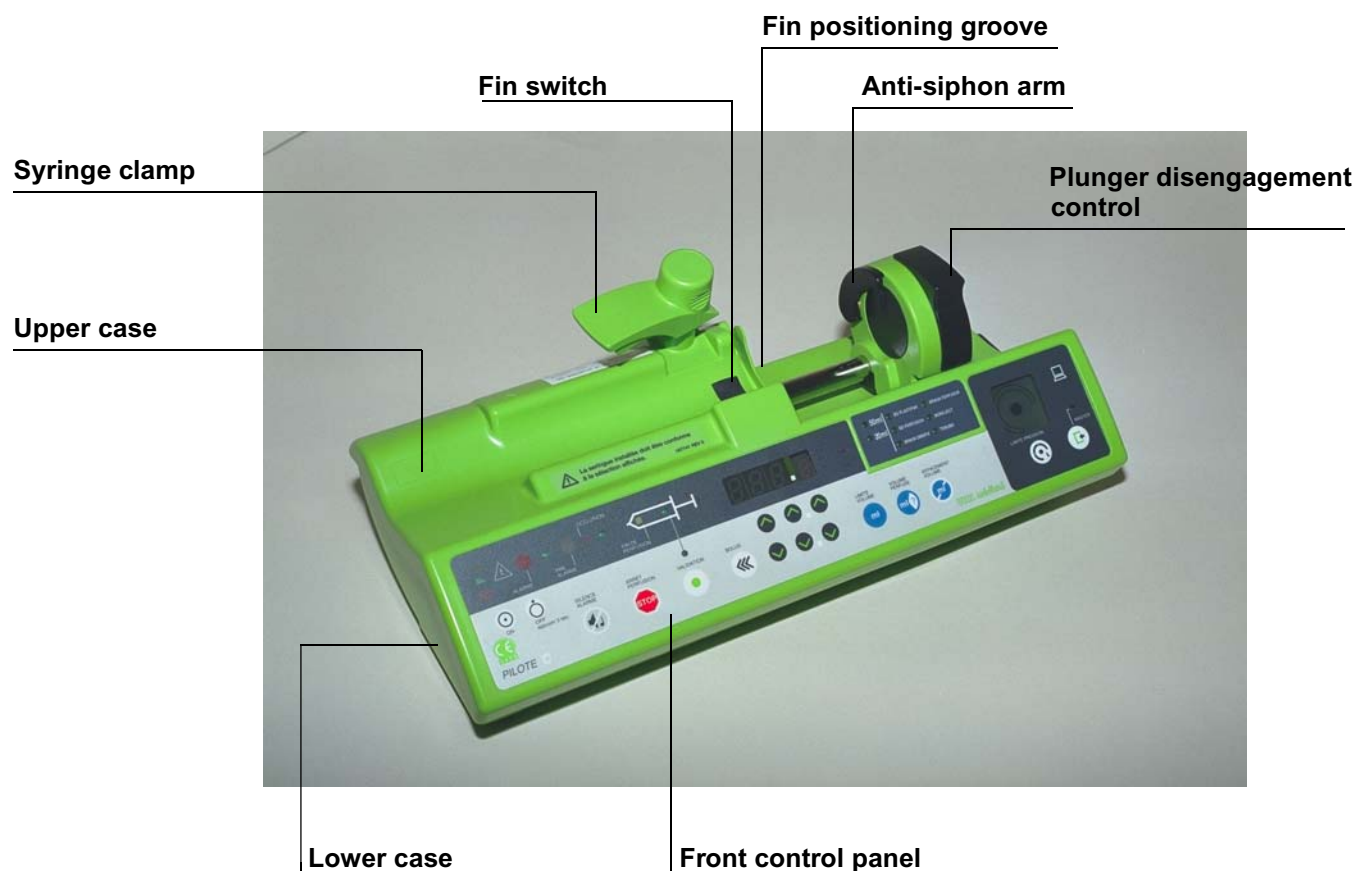

The **Pilot C** is fitted with an upper case and a lower case.

- The upper case holds the syringe clamp and contains:
 - A display board associated with the front control panel.
 - A CPU board.
- The lower case contains:
 - A power supply board and a storage battery.
 - A mechanical base unit.
 - A plunger unit.

2.1.1 The display board and the front panel

The display board is mounted under the front control panel and is fitted with all the organs required for man-machine interaction.

- Keyboard interface.
- Control lamps and overview diagrams.
- 7-segment display units.
- LCD screen.

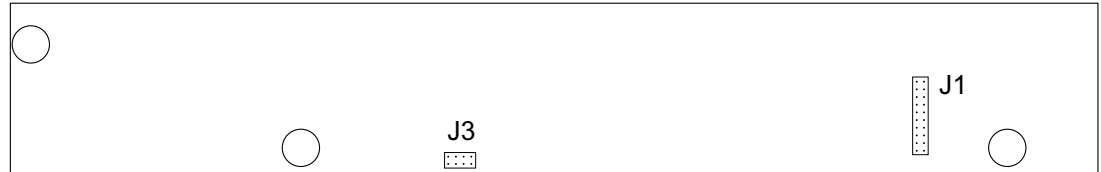

Solder side display board.



Component side display board.

This board is connected to the different parts of equipment by means of connectors.

J1 connector to CPU board

Pin	Description	
1	SEG1 display matrix	Line 1
2	SEG2 display matrix	Line 2
3	SEG3 display matrix	Line 3
4	SEG4 display matrix	Line 4
5	SEG5 display matrix	Line 5
6	SEG6 display matrix	Line 6
7	SEG7 display matrix	Line 7
8	SEG8 display matrix	Line 8
9	COL1 display matrix	Column 1
10	COL2 display matrix	Column 2
11	COL3 display matrix	Column 3
12	diode FAIL control	Fail
13	COL/DIG 9 LED type control	"
14	LIG1 keyboard interface	Line 1
15	LIG2 keyboard interface	Line 2
16	LIG3 keyboard interface	Line 3
17	LDSECT lighting control	Mains LED
18	+5V power supply	
19	VBAT power supply	
20	GND power supply	

J2 connector to keyboard

Pin	Description
1	Column 1
2	Column 2
3	Column 3
4	Column 4
5	Column 5
6	Column 6
7	Line 1
8	Line 2
9	Line 3
10	Ton
11	Toff
12	GND power supply

J3 connector to CPU board

Pin	Description
1	Ton ON key
2	Toff OFF key
3	SI SPI bus
4	Clk SPI bus
5	CSLCD SPI bus
6	Buzz BUZZER control
7	Vbat power supply
8	GND power supply

2.1.2 CPU board

The CPU board holds an 80C32 microprocessor. It is mounted and connected to the display board through J4 and J5 connectors.

A ribbon cable connects this to a power supply board by means of a connector J3.

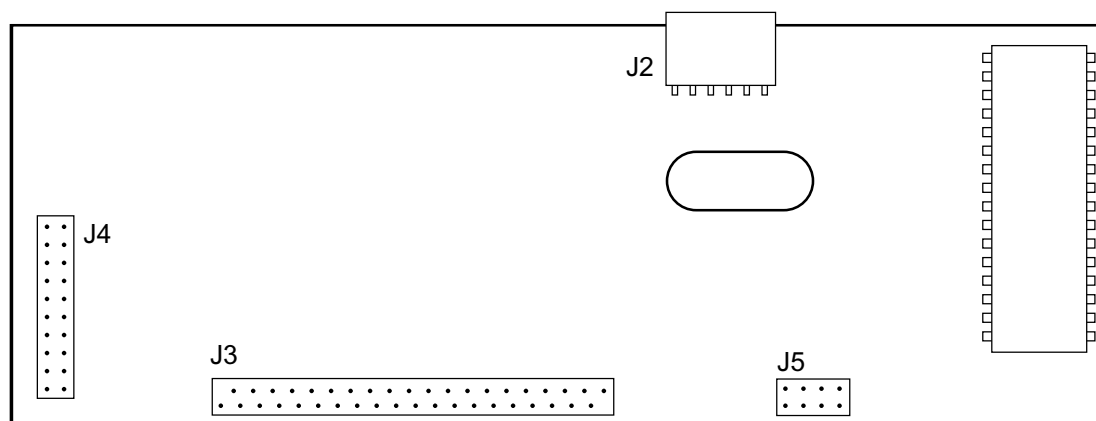

CPU board

J2 connector: to fin detection switch and syringe detection opto-electronic sensor

Pin	Description
1	Ground
2	Fin contact
3	Opto anode diode +5V
4	Common points between cathode diode , opto 1 and opto 2 transistor emitters.
5	Opto 1 transistor collector
6	Opto 2 transistor collector

J3 connector to power supply board

Pin	Description
1	+5V controlled power supply
2	GND power supply
3	+Vbat power supply
4	GND power supply
5	Phase A motor control
6	Phase B motor control
7	Phase C motor control
8	Phase D motor control
9	I signal motor control
10	Boost signal motor control
11	Sopt1 opto rotation motor output
12	Sopt2 opto anti-siphon
13	Apinfnurse call independent of the buzzer signal
14	Cdopt1 opto rotation motor control output
15	Cdopt2 opto anti-siphon module control
16	Off signal off key pressed
17	Sect mains power supply on signal
18	Cdalim power cut signal

J3 connector to power supply board

Pin	Description	
19	Ldsect mains LED control	
20	Cts clear to send	Line 2
21	Deb/off disengagement signal	
22	Rts request to send	Line 2
23	Occ/off occlusion signal	
24	Buz nurse call relay control	
25	Eoc end of adc conversion	
26	Csadc selection spi adc bus	
27	Clk clock spi adc bus	
28	Si data in spi adc bus	
29	So data out spi adc bus	
30	Cdana analogue sensor power supply control	
31	Rx2 receive data TTL	Line 2
32	Tx2 transmit data TTL	Line 2
33	Txd1 transmit data TTL	Line 1
34	Rxd1 receive data TTL	Line 1
35	Ton ON key	
36	Toff OFF key	
37	+Vbat power supply	
38	Gnd	
39	+5V	
40	Gnd	

J4 connector to keyboard

Pin	Description	
1	Seg1 display matrix	Line 1
2	Seg2 display matrix	Line 2
3	Seg3 display matrix	Line 3
4	Seg4 display matrix	Line 4
5	Seg5 display matrix	Line 5
6	Seg6 display matrix	Line 6
7	Seg7 display matrix	Line 7
8	Seg8 display matrix	Line 8
9	Col1 display matrix and keyboard	Column 1
10	Col2 display matrix and keyboard	Column 2
11	Col3 display matrix and keyboard	Column 3
12	Fail diode fail control	
13	Rdcrt current reduction control	
14	Lig1 keyboard interface	Line 1
15	Lig2 keyboard interface	Line 2
16	Lig3 keyboard interface	Line 3
17	Ldsect mains LED control	
18	+5V power supply	
19	Vbat power supply	
20	GND power supply	

J5 connector to display board

Pin	Description
1	Ton ON key
2	Toff OFF key
3	Si spi bus
4	Clk spi bus
5	Cslcd spi bus
6	Buzz buzzer control
7	Vbat power supply
8	Gnd power supply

2.1.3 The power supply board and the battery

The power supply board is mounted on the lower case. It allows to supply the electronic parts using the network 230 V AC or the external 12 / 15 DC. It also charges the 1.1 or 1.2 Ah battery.

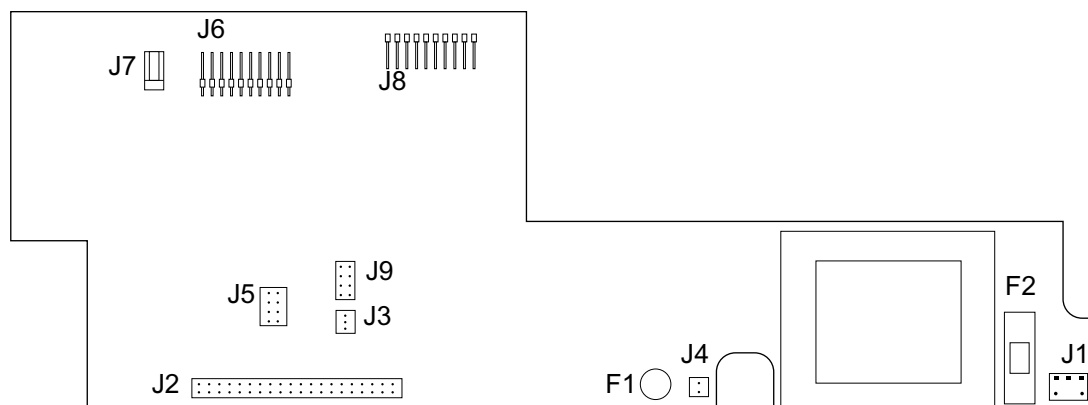

Power supply board.

This board is connected to the different parts of equipment by means of connectors.

J1 connector to CPU board

Pin	Description
1	Neutral
2	Phase

J2 connector to CPU board

Pin	Description
1	+5V controlled power supply
2	Gnd power supply
3	+Vbat power supply
4	Gnd power supply
5	Phase A motor control
6	Phase B motor control
7	Phase C motor control
8	Phase D motor control
9	I signal motor control
10	BOOST signal
11	Sopt1 opto rotation module output
12	Sopt2 opto anti-siphon module output
13	N.U
14	Cdopt1 opto rotation module control
15	Cdopt2 opto anti-siphon module control
16	Off off key pressed on the ON/OFF button
17	SECT mains supply presence signal
18	CDALIM power cut signal
19	LDSECT mains LED control
20	CTS clear to send
21	DEB/OFF disengagement signal active at 0

J2 connector to CPU board

Pin	Description	
22	RTS request to send	
23	OCC/OFF occlusion signal active at 0	
24	BUZ nurse call relay control	
25	EOC end of ADC conversion	
26	CSADC selection bus SPI ADC	
27	CLK clock bus SPI ADC	
28	SI data IN bus SPI ADC	
29	SO data out bus SPI ADC	
30	CDANA analogue sensor power supply control	
31	RX2 receive data TTL	Line 2
32	TX2 transmit data TTL	Line 2
33	TXD1 transmit data TTL	Line 1
34	RXD1 receive data TTL	Line 1
35	Toff OFF key	
36	Ton ON key	
37	+Vbat power supply	
38	Gnd	
39	+5V	
40	Gnd	

J3 connector to potentiometer

Pin	Description
1	Vref
2	Centre point
3	Gnd

J4 connector to internal battery

Pin	Description
1	+ battery
2	- battery

J5 connector to motor

Pin	Description
1	+Vbat
2	+Vbat
3	Phase D
4	Phase C
5	Phase B
6	Phase A
7	Opto rotation anode diode /+5V
8	Opto rotation cathode diode
9	Opto rotation transistor collector
10	GND/ opto rotation transistor emitter

J6 connector to RS232 and Master plugs

Pin	Description	
1	TX1 transmit data	Line 1
2	+5V	
3	RX1 receive data	Line 1
4	Gnd	
5	Interface validation	
6	Nurse call relay common point	
7	Nurse call relay normally open	
8	Nurse call relay normally closed	
9	CD ON external on	
10	CD OFF external off	
11	I-OPTION motor control output	
12	I-SECT mains led	
13	+Vbat external power supply plug	
14	RX2 receive data	Line 2
15	TX2 receive data	Line 2
16	Gnd	
17	CTS	
18	RTS	
19	BUZ	
20	NC	

J7 connector to external DC power supply

Pin	Description
1	± external power supply
2	± external power supply

J8 connector to disengagement micro-switch, force sensor and anti-siphon switch

Pin	Description
1	+Vref + internal gauge bridge
2	E1 internal gauge bridge input/occlusion on
3	E2 internal gauge bridge input/occlusion off
4	Gnd – internal gauge bridge
5	Opto anti-siphon cathode diode
6	Opto anti-siphon anode diode/+5V
7	Opto anti-siphon transistor collector
8	Disengagement micro-switch on
9	Disengagement micro-switch off
10	Gnd

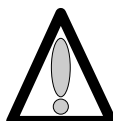

Do not forget to dismount the ribbon cable holder on the power supply board before extracting the mechanical assembly from the housing (risk of breaking the ribbon cable).

J9 connector, test points

Pin	Description
1	GND
2	Position sensor output
3	Battery discharge control output
4	Amplified force sensor output
5	N.U
6	Motor control optical switch output
7	Force and position sensor reference voltage
8	Piston head detection optical switch output

2.1.4 Mechanical gear box unit

The mechanical unit is composed of a motor-reducer block driving a screw-and-nut unit. At the shaft end, the motor receives a control panel associated with an opto-electronic switch.

The mechanical base unit also accommodates a potentiometer fitted with a rack pinion system.

2.1.5 Mechanical plunger unit

The mechanical plunger unit is mounted on the mechanical gear box. The gear box ensures the displacement movement of the plunger through a screw / nut system.

The plunger is fitted with a disengagement control allowing to separate this from the screw-and-nut system.

2.2 Functional description

From a functional point of view, the **Pilot C** is composed of three sub-assemblies :

- A syringe position control and maintenance assembly.
- A motorisation assembly.
- An external connection assembly.

2.2.1 Syringe control and maintenance assembly

The syringe is fitted into the upper case and held in position by means of a syringe clamp.

Detection of the syringe size (60 cc or 20 cc) is carried out by two opto-electronic sensors mounted onto the syringe clamp.

The fin switch ensures the syringe flanges are correctly positioned in the groove.

Associated with an opto-electronic sensor, the anti-siphon arm controls the piston position.

Composed of a force sensor fitted to the plunger, an anti-occlusion system detects the force applied on the piston and triggers an alarm whenever this force is excessive.

2.2.2 Motorisation assembly

This sub-assembly moves the piston in the syringe.

It is put into motion by means of a motor-reducer unit associated with a screw-and-nut system.

A motor rotation disk mounted on the shaft end of the motor and associated with an opto-electronic sensor controls the rotation.

A potentiometer controls the plunger movement by means of a rack pinion system.

A micro-switch allows for control of the disengagement device.

2.2.3 External connection sub-assembly

The **Pilot C** has three connectors located at the rear end of the lower case:

- A 12-15 V DC, 15 W type external power supply connector.
- An RS 232 connector.
- A Master connector for the connection of a Master module.

3 Description of the menus

3.1 Pressure parameter configuration menu

The configuration menu enables users to adapt the **Pilot** to the specific needs of each department. It provides access to the menus allowing for customisation of the parameters associated with pressure.

Fresenius Vial recommends users to implement the selected configuration procedures in the presence of a member of its qualified personnel or a member of the technical department.









*It is possible to exit the configuration mode at any time by pressing the **OFF** key.*

This menu enables users to:

- **P r E S 1**: select the occlusion alarm management mode.
- **P r E S 2**: modify the low, medium and high pressure limits.
- **P r E S 3**: modify the pressure drop detection threshold.
- **P r E S 4**: select the pressure display mode.

3.1.1 Menu access

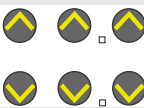
Useful keys

Key	Function
  ON OFF	ON , is used to switch the machine ON. OFF , is used to switch the machine off and, when pressed for over three seconds, to exit the configuration mode.
	SILENCE ALARM , is used to access the configuration mode.
	PRESSURE LIMIT , associated with the "SILENCE ALARM" key, allows to access the pressure configuration mode.
	The selection keys allow to scroll the figures and letters on the tenths, units, tens segments etc.
	CONFIRM , used to validate a choice.
	STOP , used to cancel the current configuration.

Pressure configuration mode setting.

- Press "SILENCE ALARM" and "PRESSURE LIMIT" simultaneously.
- Maintain this position while pressing "ON".
- When $P r E 5$ is shown on the display unit, release the selection of "SILENCE ALARM" and "PRESSURE LIMIT" then validate within three seconds by pressing "CONFIRM".
- $P r E 1$ is shown by default.
- Switching from $P r E 1$ to $P r E 4$ is carried out using the "tenths" keys.

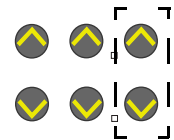
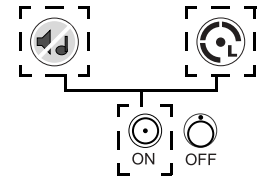

3.1.2 $P r E 1$, configuration of the occlusion alarm

This configuration enables users to select the occlusion alarm management mode.

- $n 1 U 3$, the alarm is managed according to one of the three pressure limit values (low, medium or high).
- $U R r 1$, the alarm is managed according to one single pressure limit value:
 - equal to the last value selected during use,
 - or configurable in increments of 50 mmHg (between 100 and 900 mmHg).

If $n 1 U 3$:

- $P r E 1$, press "CONFIRM".
 - Select the mode $n 1 U 3$ using the keys.
 - Press "CONFIRM".
 - Select the pressure limit value 1, 2 or 3 using the keys.
 - Press "CONFIRM".

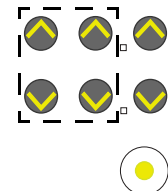

If $U R r 1$:

- $P r E 1$, press "CONFIRM".
 - Select the mode $U R r 1$ using the keys.
 - Press "CONFIRM".
 - Select the default limit value using the keys:
 - ♦ ---: this will be equal to the last value selected,
 - ♦ or display the value to be configured by increments of 50 mmHg.
 - Press "CONFIRM" to memorise it.

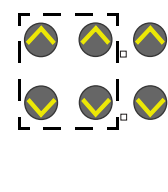

The modification may be cancelled by pressing the "STOP" key.

It is possible to exit the configuration mode at any time by pressing the "OFF" key.



3.1.3 *P r E 2*, pressure limit configuration

This configuration enables users to select the values from the 3 pressure limit thresholds (low, medium or high).

Limit	Min. value	Max. value	Comments
Low	50 mmHg	300 mmHg	Common to 20 and 50 ml syringes.
Medium	lower limit + 100 mmHg	800 mmHg	Common to 20 and 50 ml syringes.
High	medium limit +100 mmHg	900 mmHg	Specific to each 20 and 50 ml type syringe.



The high limit values are also used as minimum values when setting the pressure limits in U R r 1 mode.

■ *P r E 2*, press "CONFIRM"

- The value of the lower limit is displayed e.g. 300. . .
 - ♦ Modify its value using the "tens" keys.

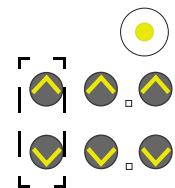

- ♦ Press "CONFIRM"



- The value of the medium limit is displayed e.g. 500. . .
 - ♦ Modify its value using the "tens" keys.

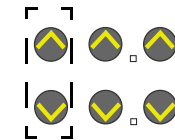

- ♦ Press "CONFIRM".



- The value of the higher limit for 50 ml syringes is displayed e.g. 900. . .
 - ♦ Modify its value using the "tens" keys.

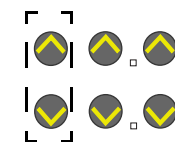

- ♦ Press "CONFIRM"



- The value of the higher limit for 20 ml syringes is displayed e.g. 900. . .
 - ♦ Modify its value using the "tens" keys.

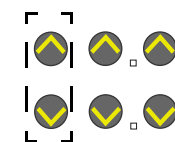

- By validating once again, the 3 limits are memorised and it is possible to select another configuration .



The modification may be cancelled by pressing the "STOP" key.

It is possible to exit the configuration mode at any time by pressing the "OFF" key.



3.1.4 *P r E 3*, configuration of the pressure drop detection threshold



*This configuration is only accessible if the occlusion alarm is managed in *U R r 1* mode.*

This configuration allows for setting of the threshold used for dynamic supervision of the pressure drop. During infusion, an alarm is triggered when the pressure in the syringe exceeds this threshold and then drops back under threshold limits.

This threshold should be between 50 and 900 mmHg.

■ *P r E 3*, press "CONFIRM"

- The value of the threshold is displayed e.g. *100*.

- ♦ Modify its value using the "tens" keys.

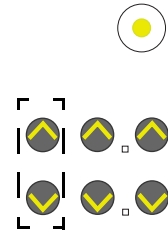

- By validating once again, the value is memorised and it is possible to select another configuration .



The modification may be cancelled by pressing the "STOP" key.

It is possible to exit the configuration mode at any time by pressing the "OFF" key.



3.1.5 *P r E 4*, configuration of the pressure display mode

This configuration enables users to choose whether or not to alternately display the pressure in the syringe with the active pressure limit threshold.

■ *P r E 4*, press "CONFIRM"

- If *R F F*, in operation, pressing the "PRESSURE LIMIT" key will trigger the display of the pressure in the syringe alternately with the active pressure limit value (low, medium or high).
- If *n o R F*, in operation, pressing the "PRESSURE LIMIT" key will trigger the display of the active pressure limit value (low, medium or high).

- ♦ Select the display mode using the keys.

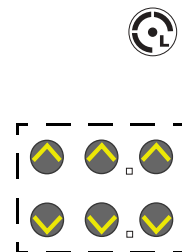

- By validating once again, the display mode is memorised and it is possible to select another configuration.



The modification may be cancelled by pressing the "STOP" key.

It is possible to exit the configuration mode at any time by pressing the "OFF" key.



3.2 Configuration menu of the current operation parameters

The configuration menu enables users to adapt the **Pilot** to the specific needs of each department. It provides access to the menus allowing for customisation of the parameters associated with current operation modes.

Fresenius Vial recommends users to implement the selected configuration procedures in the presence of a member of its qualified personnel or a member of the technical department.







*It is possible to exit the configuration mode at any time by pressing the **OFF** key.*

This menu enables users to:

- **PAR 1**: select the type of flow rate memorisation.
- **PAR 2**: select the syringe selection mode.
- **PAR 3**: modify the maximum flow rates which can be selected using the keyboard.
- **PAR 4**: configure the list of syringes that can be selected.
- **PAR 5**: select the compulsory priming.
- **PAR 6**: select the start-up system.
- **PAR 7**: select the KVO flow rate.
- **PAR 9**: select the RS232 communication speed.
- **PAR R**: select the empty syringe mode.
- **PAR b**: select the frequency of preventive checks.
- **PAR C**: select the drug display mode.
- **PAR d**: choose whether or not to activate the fin detection mode.
- **PAR F**: select the Bolus memorisation mode.
- **PAR G**: enter the list of drugs.
- **PAR J**: choose whether or not to activate the mains disconnection signal.

3.2.1 Menu access

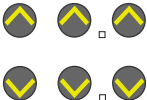
Useful keys

Key	Function
 ON OFF	ON , is used to switch the machine ON. OFF , is used to switch the machine off and, when pressed for over three seconds, to exit the configuration mode.
	SILENCE ALARM , is used to access the configuration mode of the current operation parameters.
	The selection keys allow to scroll the figures and letters on the tenths, units, tens segments etc.
	CONFIRM , is used to validate a choice.
	STOP , is used to cancel the current configuration.

Switch to configuration mode.

- Press "SILENCE ALARM" and "TENS" simultaneously.
- Maintain this position while pressing "ON".

- When PAR is shown on the display unit, release the selection of "SILENCE ALARM" and "TENS" then validate within three seconds by pressing "CONFIRM".
- $PAR 1$ is shown by default.
- Switching from $PAR 1$ to $PAR 2$ is carried out using the "tenths" keys.

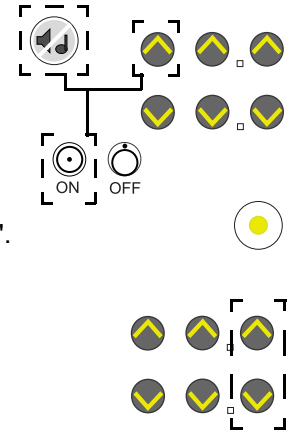

3.2.2 $PAR 1$, configuration of the memorisation type

This configuration enables users to choose whether or not to memorise the infusion flow rate when the **Pilot** is shut down.

- $PAR 1$, press "CONFIRM"
 - If MEM , the flow rate is memorised when the **Pilot** is shut down, this value will be displayed by default when the machine is next switched on.
 - If $NO MEM$, the flow rate is not memorised, the default value is 00.0 each time the machine is switched on.
 - ◆ Select the memorisation type using the selection keys.
- By validating once again, the type is memorised and it is possible to select another configuration .

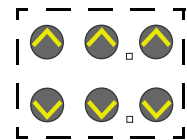

The modification may be cancelled by pressing the "STOP" key.

It is possible to exit the configuration mode at any time by pressing the "OFF" key.



3.2.3 *P A r 2*, configuration of the syringe selection type

This configuration enables users to choose the type of syringe selection.

■ *P A r 2*, press "CONFIRM" 

- If *S E L 3*, automatic validation of the only syringe that may be selected.
- If *S E L 4*, when the **Pilot** is switched on, the user should select the type of syringe installed.

- ◆ Choose the selection type using the selection keys.

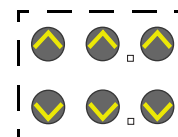

- By validating once again, the type is memorised and it is possible to select another configuration . 



When mode S E L 3 is selected, and if there is a choice of more than one syringe, the Pilot automatically moves onto the configuration of the list of syringes that may be selected P A r 4 when the machine is next switched on.



The modification may be cancelled by pressing the "STOP" key.

It is possible to exit the configuration mode at any time by pressing the "OFF" key.



3.2.4 *P A r 3*, configuration of the maximum flow rate that may be selected on the keyboard

This configuration enables users to choose the maximum flow rate that may be selected using the keyboard for each type of syringe.

Syringe type	Min. flow rate (ml/hr)	Max. flow rate (ml/hr)
50/60 cc	0,1	800
20 cc	0,1	400

■ *P A r 3*, press "CONFIRM" 

- Select the syringe type using the keys.

- ◆ *20 c*, 20 ml.
- ◆ *50 c*, 50 ml.

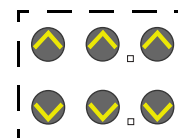

- Press "CONFIRM" 

- ◆ Select the maximum flow rate using the keys.

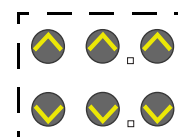

- By validating once again, the type is memorised and it is possible to select another configuration .



The modification may be cancelled by pressing the "STOP" key.



It is possible to exit the configuration mode at any time by pressing the "OFF" key.



3.2.5 *PAR 4*, configuration of the list of syringes that may be selected

This configuration enables users to choose whether or not it may be selected for each type of active syringe.

- *PAR 4*, press "CONFIRM"



- The LED of the syringe to be configured flashes.
 - ♦ If *SEL*, this type of syringe may be selected when the **Pilot** is switched on.
 - ♦ If *no SEL*, this type of syringe may not be selected when the **Pilot** is switched on.

- Make your choice using the keys.

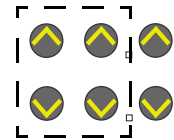

- Press "CONFIRM" to memorise the modification.



- The LED of the configured syringe is:
 - ♦ Lit up is it may be selected.
 - ♦ Off if it may not be selected.



Details of the syringe are displayed when the "tenths" keys are pressed (see "Typical syringe/details correspondence table").

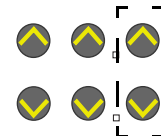

The modification may be cancelled by pressing the "STOP" key.



It is possible to exit the configuration mode at any time by pressing the "OFF" key.



3.2.6 *P A r S*, configuration of the compulsory priming

This configuration enables users to choose whether or not priming is compulsory after selection of a syringe.

- *P A r S* is displayed.
 - Press "CONFIRM"
 - ◆ If *P u r S*, compulsory priming, pressing "BOLUS" during start-up is compulsory to switch to selection of the flow rate.
 - ◆ If *n o P u*, priming is not compulsory, the flow rate may be selected upon start-up straight after validation of the syringe.



- Make your choice using the keys.

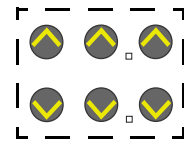

- By validating once again, the type is memorised and it is possible to select another configuration .



The modification may be cancelled by pressing the "STOP" key.



It is possible to exit the configuration mode at any time by pressing the "OFF" key.



3.2.7 *P A r S*, configuration of the rapid infusion start-up

This configuration enables users to choose whether or not to activate the rapid infusion start-up system.

- *P A r S*, press "CONFIRM"
 - If *S t A r*, rapid infusion start-up activated, when the flow rate is low, the plunger moves quicker upon infusion start-up until it comes into contact with the syringe piston. This fast movement is controlled by the force sensor and is limited in distance.
 - If *n o S t*, no rapid start-up, the infusion always starts with the flow rate selected even if this is low.



- ◆ Make your choice using the keys.

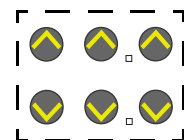

- By validating once again, the type is memorised and it is possible to select another configuration .



The modification may be cancelled by pressing the "STOP" key.



It is possible to exit the configuration mode at any time by pressing the "OFF" key.



3.2.8 *PAR 7*, configuration of the KVO flow rate

This configuration enables users to choose whether or not to activate the switching to KVO flow rate.

■ *PAR 7*, press "CONFIRM" 

- If *100*, KVO flow activated, the infusion continues at 1,0 ml/hr (or at the same flow rate if this is under 1,0 ml/hr) when the volume infused reaches the limit volume.
- If *not 0*, no KVO flow, infusion stops with a limit volume alarm when the infused volume reaches the limit volume.

Make your choice using the keys.

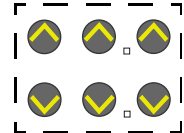

By validating once again, the type is memorised and it is possible to select another configuration .



The modification may be cancelled by pressing the "STOP" key.



It is possible to exit the configuration mode at any time by pressing the "OFF" key.



3.2.9 *PAR 9*, configuration of the RS232 communication speed

This configuration enables the user to select the communication speed of the RS232 link.

■ *PAR 9*, press "CONFIRM" 

- If *19200*, speed at 19200 Bauds.
- If *9600*, speed at 9600 Bauds.
- If *4800*, speed at 4800 Bauds.

Make your choice using the keys.

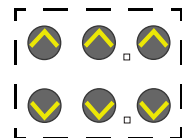

By validating once again, the type is memorised and it is possible to select another configuration .



The modification may be cancelled by pressing the "STOP" key.



It is possible to exit the configuration mode at any time by pressing the "OFF" key.





3.2.10 P A r A , configuration of the empty syringe mode

This configuration enables users to select a type of operation for the instrument using the empty syringe mode.

- P A r A , press "CONFIRM" 
 - If S U I d , empty syringe mode activated.
 - If S U I d , empty syringe mode deactivated.

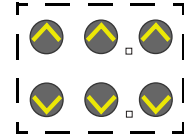
- Make your choice using the keys.



- By validating once again, the type is memorised and it is possible to select another configuration . 



The modification may be cancelled by pressing the "STOP" key.

It is possible to exit the configuration mode at any time by pressing the "OFF" key.





3.2.11 P A r b , configuration of the frequency of preventive checks

This configuration enables users to select the maintenance frequency which lies between 1 and 9999 hours.

- P A r b , press "CONFIRM" 
 - The current value is displayed.

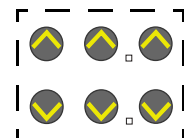
- Display the new frequency value using the keys.



- By validating once again, the type is memorised and it is possible to select another configuration . 



The modification may be cancelled by pressing the "STOP" key.

It is possible to exit the configuration mode at any time by pressing the "OFF" key.





3.2.12 P A r C , configuration of the drug display mode

This configuration enables users to choose whether or not to display the first four letters of the name of the drug used.

- P A r C , press "CONFIRM" 
- If d r U G , display activated, after validation of the syringe type, the operator should select the name of the drug used out of the choice of 15 names.
- If n o d r , display deactivated, the **Pilot** does not offer a choice of drug names.

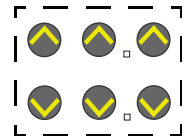
- Make your choice using the keys.



- By validating once again, the type is memorised and it is possible to select another configuration . 



If The modification may be cancelled by pressing the "STOP" key.

It is possible to exit the configuration mode at any time by pressing the "OFF" key.





3.2.13 P A r d , configuration of the fin detection mode

This configuration enables users to choose whether or not to activate the fin position check.

- P A r d , press "CONFIRM" 
- If A i L E , detection activated, inappropriate positioning of the fin is signalled by means of an alarm.
- If n o A L , no detection, the inappropriate positioning of the fin is not checked.

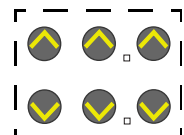
- Make your choice using the keys.



- By validating once again, the type is memorised and it is possible to select another configuration . 



The modification may be cancelled by pressing the "STOP" key.

It is possible to exit the configuration mode at any time by pressing the "OFF" key.



3.2.14 P A r F , configuration of the bolus flow memorisation mode

This configuration enables users to select the bolus flow memorisation mode.

■ P A r F , press "CONFIRM" 

- If *n E n*, bolus memorised, upon start-up of the **Pilot**, the bolus flow given corresponds to the last selected.
- Si *n o n E*, bolus not memorised, upon start-up of the **Pilot**, the bolus flow given is that defined by default.

- Make your choice using the keys.

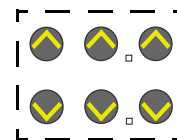

If the "not memorised" mode is selected, the bolus default value must be defined.

- If the *n o n E* is selected, the 50 cc LED lights up and the bolus flow is displayed.
 - ♦ Using the keys, enter the bolus value to be defined by default for a 50 cc syringe.

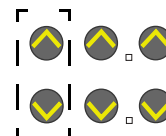

- ♦ Press "CONFIRM" to memorise it 

- The 20 cc LED lights up and the bolus flow is displayed.
 - ♦ Using the keys, enter the bolus value to be defined by default for a 20 cc syringe.

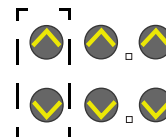

- By validating once again, the type is memorised and it is possible to select another configuration . 



The modification may be cancelled by pressing the "STOP" key.

It is possible to exit the configuration mode at any time by pressing the "OFF" key.





3.2.15 *P A r U*, configuration of the drugs list

This configuration enables users to enter the list of drugs that may be used by the **Pilot**.

■ *P A r U*, press "CONFIRM" 

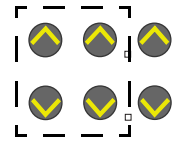
- The first four letters of the drug name are displayed.
 - ♦ The first letter flashes.
 - ♦ Modify the first letter using the "tens" or "units" keys.



- Press "CONFIRM" to memorise it and move onto the next letter 

- When the last letter is validated, the next drug is displayed.

- To validate the one or several modification(s), the entire list of drugs must be scrolled. When the last drug is validated, the *P A r U* menu is displayed.



The modification may be cancelled by pressing the "STOP" key.



It is possible to exit the configuration mode at any time by pressing the "OFF" key.



3.2.16 *P A r U*, configuration of the mains disconnection signal

This configuration enables users to choose whether or not to activate the power cut detection beep.

■ *P A r U*, press "CONFIRM" 

- If *S E C . t*, detection activated, a power cut is signalled by a beep.
- If *n o S, E*, no detection.

- Make your choice using the keys.

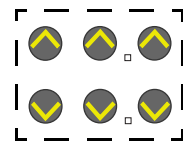

- By validating once again, the type is memorised and it is possible to select another configuration . 



The modification may be cancelled by pressing the "STOP" key.



It is possible to exit the configuration mode at any time by pressing the "OFF" key.



3.2.17 Typical syringe/details correspondence table

Brand	Capacity (ml)	Details
BD Perfusion	50	BPf
BD Plastipak	50	BDk
BD Plastipak	20	BDk
Braun Omnifix	50	BrO
Braun Omnifix	20	BrO
Braun Perfusor	50	BrP
Braun Perfusor	20	BrP
Didactic Line France	50	DiL
Didactic Perfusion	50	DiP
Dispomed Spritze	50	Dis
Fresenius Injectomat	50	FrI
Fresenius P Spritze	50	FrP
Ivac	50	IVa
Map Gliss L L	50	MLL
Map Pic L L (Indolor)	50	MPL
Sherwood Monoject	50	SMJ
Sherwood Monoject	20	SMJ
Terumo	50	Trm
Terumo	20	Trm
Tutoject type T	50	TJT

3.3 Calibration menu

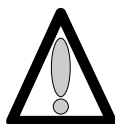

The calibration menu is reserved for authorised personnel only, its access is protected by a secret code.

To determine the operation mode of the different calibrations, refer to the "Calibrations" chapter

This menu allows for calibration:

- *ETR4* : three levels of battery voltage alarms.
- *ETR6* : displacement potentiometer.
- *ETR9* : force sensor.

3.4 ASS test menu

The ASS test menu is reserved for authorised personnel only. It enables users to perform a series of **Pilot** inspections to validate its efficient operation (see "**Checks**" chapter). This must be carried out each time parts are replaced.



The ASS tests may also be performed more easily and more quickly using a PC with installed maintenance software (consult our After Sales Service).

The ASS test menu enables users to perform a series of 17 tests or checks:

- *t S t 1*: Display of the running time and the maintenance date.
- *t S t 2*: Indicator lights test.
- *t S t 3*: Keyboard test.
- *t S t 4*: Display of the battery voltage.
- *t S t 5*: Display of the codes of the last 10 alarms.
- *t S t 6*: Display of the total running time.
- *t S t 7*: TTL serial link test.
- *t S t 8*: RS 232 serial link test.
- *t S t 9*: Display of the piston force.
- *t S t A*: Display of the software version.
- *t S t b*: Display of the analogue input.
- *t S t C*: Display of the plunger position.
- *t S t d*: Buzzer test.
- *t S t E*: Display of the calibration values.
- *t S t F*: Display of the syringe type.
- *t S t G*: Display of the syringe group.
- *t S t H*: Display of the list of syringes.

4 Preventive maintenance

4.1 Recommendations

The **Pilot** syringe pump can only be inspected, serviced or repaired by **Fresenius Vial** or by an authorised and appointed service. The qualified technicians in your establishment and our After Sales Service should be notified of any abnormal operation of the device.

If a repair is necessary, send the instrument in its original packaging if possible with a precise description of the observed fault, to the official dealer for **Fresenius Vial**.

For further information concerning troubleshooting or the usage procedure, please contact our After Sales Service or our Sales Department.

Fresenius Vial is not liable for loss or damage to the equipment during transport to our After Sales Service.

4.2 Maintenance schedule

4.2.1 Use beyond the framework of the departmental order

Frequency	Name
12 months	Carry out a servicing inspection.
3 years	Replace the battery (see "Battery-holder and battery" operation sheet).

4.2.2 Use within the framework of the departmental order

When the equipment is used within the framework of the departmental order of October 3 1995, inspections are performed on a less frequent basis. This is due to the fact that the equipment is inspected before each use.

Frequency	Name
1 st inspection in the 3 rd year	Perform the first servicing inspection.
Then every 2 years	Perform a servicing inspection.
3 years	Replace the battery (see "Battery-holder and battery" operation sheet).

4.3 Checks



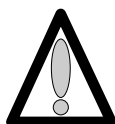



In order to perform equipment follow-up by means of preventive maintenance, a regular servicing inspection is recommended every 12 months (see "Regular servicing sheet").



To ensure the check procedure is carried out efficiently, recharge the battery beforehand (16 hours).

4.3.1 Test access

Keyboard description

Key	Function
  ON OFF	ON , is used to switch the machine ON. OFF , is used to switch the machine off when pressed for over three seconds.
	SILENCE ALARM , to access the test mode.
	STOP , to cancel the test in progress.
	CONFIRM , to validate a choice.
	"PRESSURE LIMIT" , backpressure test.
	The selection keys allow to scroll the figures and letters on the tenths, units, tens segments etc.

Activate the ASS test

- Press "SILENCE ALARM" and "UNITS" keys simultaneously.
- Maintain this position while pressing "ON".
- When $t\ 5\ t .$ is displayed on screen, release selection of the "SILENCE ALARM" and "UNITS" keys, then validate within three seconds by pressing the "CONFIRM" key.
- By default, the equipment starts with test n°1 $t\ 5\ t . 1$
- By using the selection keys "+ or -", scroll the different tests on the display unit.

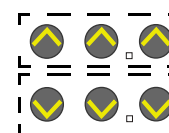
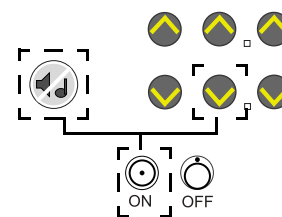

4.3.2 Visual check

Check the general appearance of the case and labels, and check for any traces of shock.

4.3.3 Running time and servicing inspection date

This test allows for display of the **Pilot** running time since its last servicing inspection. It also allows for display and modification of the "last" servicing inspection date. When the servicing inspection date is modified, the running time is reset.

- t S t . 1 , press the "CONFIRM" key.
 - If J J J . H : number of hours of use, 999 hours max.
 - If J J J . d : number of days of use, 999 days max.
 - If J J J . n : number of months, 999 months max. (average duration of one month considered as 30 days).
 - If [t r L is displayed alternately, the result exceeds the max. servicing frequency memorised (see "PArb, configuration of the frequency of preventive checks"): carry out preventive maintenance procedures.
 - ♦ By keeping the "tenths" keys pressed down, the number of times the equipment has been switched on is displayed.
- Press "CONFIRM" again to display the date of the last servicing inspection.
 - J J . d , day of the servicing inspection date.
 - Validate once again,
 - ♦ J J . n , month of the servicing inspection date.
 - By validating once again,
 - ♦ J J J . J , year of the servicing inspection date.

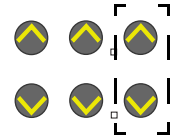

Each time this information is read, the month, day and year of the servicing inspection date may be modified by using the tens and units "-" and "+" keys. This date will be stored in the EEPROM and the running time will be reset.

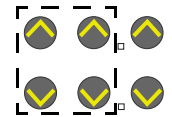

- By validating once again, a different test may be selected.



The test may be stopped at any time by pressing the "STOP" key, and a different test may be selected.



4.3.4 Indicator lights check

This test checks the efficiency of the indicator lamps, the display units and the front panel LCD screen.

- t S t . 2 , press "CONFIRM".
 - All LEDS, 7-segment display units and pressure LCD are ON.
 - By validating once again,
 - ♦ The LEDS and display units are scrolled one by one from left to right. (display of the LEDS, 7-segment display unit by segment and then by sets of 8, LCD pressure display unit with 10 arrow positions as well as the symbols).

The text is OK if all indicator lamps are lit up.



The test may be stopped at any time by pressing the "STOP" key, and a different test may be selected.



4.3.5 Keyboard check

This test allows to check that all keyboard keys function correctly.

- *tSt.3*, press "CONFIRM".
 - The message *CLAU* is displayed.
 - Keep each key pressed down, one by one,
 - ◆ Check the name of the key displayed on the display unit.

The name of each key is displayed as follows:

Display	Selected key
<i>SIR.L</i>	SILENCE ALARM
<i>StoP</i>	STOP
<i>UAl</i>	CONFIRM
<i>boLu</i>	BOLUS
<i>S-..</i>	+ tens
<i>S.-.</i>	+ units
<i>S..-</i>	+ tenths
<i>S...-</i>	- tens
<i>S...-</i>	- units
<i>S...-</i>	- tenths
<i>ULIN</i>	LIMIT VOLUME
<i>UPEr</i>	VOLUME INFUSED
<i>UDEF</i>	CLEAR VOLUME
<i>PrES</i>	PRESSURE
<i>MASt</i>	MASTER



If two or more keys are held down simultaneously, the display unit will show *Err* and a sound alert will ring out "beep!beep!beep!" indicating an error.
The "OFF" key is not included in the keyboard check.



The test may be interrupted at any time by pressing the "CONFIRM" key for over three seconds, and a different test may be selected.



If the display is faulty, replace the display board (see "Display unit and central unit boards" operation sheet).

4.3.6 Battery voltage check

This test allows for display of the battery voltage in Volts and in tenths of a Volt.

- **ESC.4**, press "CONFIRM".
 - The voltage is displayed in Volts.
 - By validating again, a different test may be selected.



The test may be stopped at any time by pressing the "STOP" key, and a different test may be selected.



4.3.7 Checking the last 10 alarms

This test allows for code display of the last 10 alarms triggered on the Pilot.

- **ESC.5**, press "CONFIRM".
 - The code of the most recent alarm is displayed **JJJ.0**.
 - Press the keys to display the following codes from **JJJ.1** to **JJJ.9**.
 - By validating again, a different test may be selected.

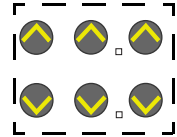

The test may be stopped at any time by pressing the "STOP" key, and a different test may be selected.



Meaning of the codes:

Alarm	Description	Error	Description
A10	Battery alarm	E50	ADC access auto-test error.
A11	Syringe support alarm	E60	Error concerning checking of syringe parameter coherence (incoherence of the syringe diameter in relation to the motor step for 0,1 ml calculated at the time of syringe validation).
A12	End of infusion alarm	E70	Error concerning motor frequency anomaly (motor step period calculated in relation to the syringe diameter and the flow rate selected which is either too low or too high).
A13	Limit volume alarm	E80	Error concerning keypad fault or high electromagnetic interference.
A14	Disengagement alarm	E01	Error concerning rotation check.
A15	Piston head alarm	E32	Error concerning segment advance check
A16	Occlusion alarm	E52	Error concerning advance check during take-up.
A17	Fin alarm	E72	Error concerning advance over the whole length.
		E03	Error concerning communication

- Errors 10, 20,30 and 40 cannot be stored in the EEPROM.
- If the pilot switches off normally, the **OFF** message is displayed.
- If the Pilot switches off due to a malfunction, the **OFF** message is displayed with a flashing **F**.

4.3.8 Total running time check

This test enables users to display the total running time of the **Pilot**. It is not possible to modify this time manually.

- $t 5 t . 6$, press "CONFIRM".
 - If $j j j . H$: number of hours of use, 999 hours max.
 - If $j j j . d$: number of days of use, 999 days max.
 - If $j j j . m$: number of months, 999 months max. (average duration of one month considered as 30 days).
 - ◆ By keeping the "tenths" key pressed down, the number of times the device has been switched on is displayed.
- By validating once again, a different test may be selected.

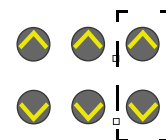

The test may be interrupted at any time by pressing the "STOP" key, and a different test may be selected.



4.3.9 TTL serial link test

This test enables users to check the efficiency of the TTL (80C32) serial link.

- To perform this test, use plug on which lines Rx and Tx are short-circuited (2 and 3).
- $t 5 t 7$, press "CONFIRM".
 - $L t$ is displayed at the start of the test.
 - ◆ If $L t E r$ is displayed, the test is not successful, otherwise, the test is successful.
 - By validating once again, a different test may be selected.



The test may be interrupted at any time by pressing the "STOP" key, and a different test may be selected.





It is impossible to carry out this test when the PC is in communication with the Pilot. In this case, "OPEN" is displayed.

4.3.10 RS 232 serial link check

This test enables users to check the efficiency of the RS 232 (2691) serial link.

To perform this test, use a plug on which lines Rx and Tx, RTS and CTS are short-circuited (2 and 3, 7 and 8).

- **5 5 8**, press "CONFIRM". 
- **NO UART** is displayed if the UART is missing, in this case the test cannot be carried out.
- RTS and CTS line operation test.
 - ◆ If the test is unsuccessful, **NO RT C** is displayed, in which case the test cannot be continued.
- **L r** is displayed.
 - ◆ If **L r E r** is displayed, the test is not successful, otherwise, the test is successful.
- By validating once again, a different test may be selected. 





The test may be interrupted at any time by pressing the "STOP" key, and a different test may be selected. 

It is impossible to carry out this test when the PC is in communication with the Pilot. In this case, "OPEN" is displayed.

4.3.11 Checking the force sensor



This test enables users to display the force exerted on the piston.

- **5 5 9**, press "CONFIRM". 
- **000.9** : displayed in grams, the result must lie between 0 and 100 g.
- Press and release the bonding pad.
 - ◆ The result displayed must always lie between 0 and 100 g.
- By validating once again, a different test may be selected. 

If the value is out of limits, recalibrate the force sensor (see "5 5 9 Force sensor calibration.").

4.3.12 Checking the software version

Run this test to display the software version and revision numbers.

- **5 5 A**, press "CONFIRM". 
- eg. **U09.6** is displayed:
 - ◆ **09**, software version number.
 - ◆ **.6**, revision number
- Press the tenths keys to display the EPROM checksum, e.g. **U0CF.1**.
- Press the other keys to display the software version index e.g. **.A**.
- By validating once again, a different test may be selected. 

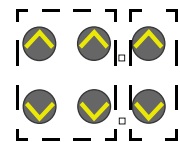

The test may be interrupted at any time by pressing the "STOP" key, and a different test may be selected. 

4.3.13 Checking the ADC

Run this test to read the results, in hexadecimals, of the conversion of the five analogue inputs and three test inputs of the converter.

- t 5 t .b , press "CONFIRM".
 - The result displayed is the first of the five analogue inputs (from 0 to 4), for example 318.0 .
 - The second type of result displayed corresponds to the converter test according to the channel number, J J J .L is the 0 test input, J J J .N is the mid-scale test input, and J J J .H is the ADC full scale test input.



Use the "-" and "+" selection keys to move from one input to another.

- Press the plus of the selected item twice:
 - ◆ J J J .2 reading of input 2, the displayed value must lie between 066 and 08F. This reading gives an amplifier output value of $0,6V \pm 0,05 V$.
- By validating once again, a different test may be selected.

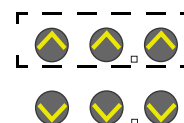

If the value is out of limits, recalibrate the force sensor (see "E t R .9 Force sensor calibration.").

4.3.14 Checking the position sensor

This test enables users to display the plunger position in mm and 10^{ths} of a mm.

- t 5 t .C , using spacers ref. T300940E and T300775G,
 - Position the spacer ref. T300940E and press "CONFIRM".
 - ◆ in high position the display unit shows $115.0 \pm 0,5 \text{ mm}$.
 - Position the spacer ref. T300775G and press "CONFIRM".
 - ◆ in low position the display unit shows $20.0 \pm 0,5 \text{ mm}$.
 - By validating once again, a different test may be selected.



If the value is out of limits, recalibrate the position sensor (see "E t R .5 Position sensor calibration.").

4.3.15 Buzzer test

Run this test to check that the buzzer is working.

- `tSt.d`, press "CONFIRM". 
- The buzzer sounds continuously and the `bEEP` message is displayed.
- By validating once again, a different test may be selected.

4.3.16 Display of the calibration values

Run this test to display the calibration values stored in the EEPROM.

- `tSt.E`, press "CONFIRM". 
- `bAt.1` is displayed alternately with its calibration value.
 - ♦ Press one of the tenths keys to display the number of calibrations carried out for this value
- Press one of the unit or tenths keys to move onto another value.

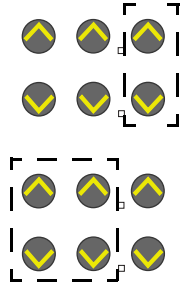

Display	Name
<code>bAt.1</code>	Alarm and pre-alarm battery voltage 6.3 V
<code>bAt.2</code>	Pre-alarm battery voltage 5.9 V
<code>bAt.3</code>	Alarm battery voltage 5.7 V
<code>H10.H</code>	Displacement potentiometer with large 115.0 mm spacer
<code>L00</code>	Displacement potentiometer with small 20.0 mm spacer
<code>0.0</code>	Force sensor with 0 kg
<code>5t.0</code>	Force sensor with 5 kg

4.3.17 Checking the syringe clamp

This test displays the type of syringe fitted to the **Pilot**.

- `tSt.F`, press "CONFIRM" 
- with a 50 cc and 20 cc capacity syringe.
 - Place the syringe clamp in the higher position. The display unit shows `- - - . -`
 - Fit the 50 cc syringe. The display unit shows `50 cc`
 - Fit the 20 cc syringe. The display unit shows `20 cc`
 - Place the syringe clamp in the lower position. The display unit shows `- - - . -`



Capacities which are non-existent or non-configured in the EEPROM are displayed in the form of `- - - . -`.

- By validating once again, a different test may be selected. 

4.3.18 Checking the syringe group number

Run this test to determine for which list of syringes the instrument has been configured.

- **555.G**, press "CONFIRM".
 - The syringe group number configured in EEPROM is displayed, for example **001**.
 - By validating once again, a different test may be selected.



4.3.19 Checking the list of syringes

This test enables users to display the list of syringes programmed in the Pilot.

- **555.H**, press "CONFIRM".
 - The syringe capacity is displayed and the corresponding Led lights up.
 - Each time a key is pressed:
 - ♦ The syringe details are displayed.
 - ♦ The Led corresponding to the details lights up.
 - ♦ The one or several Led(s) corresponding to the capacities light(s) up.
 - Press stop to select a different test.

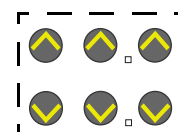

4.3.20 Checking the disengagement system

To carry out this operation, exit the test mode and press "OFF".



- Press "ON".
 - Lift the disengagement lever.
 - ♦ Check for presence of the mechanical disengagement alarm (red Led at the end of the syringe diagram).
 - Fit the device with the 50 cc syringe, ensuring the fin and plunger are in position.
 - Release the disengagement lever.
 - ♦ Ensure there is no mechanical lever release alarm.
 - ♦ Check the linear plunger locking.



4.3.21 Checking the fin detection system

To carry out this operation, exit the test mode and press "OFF".



- Press "ON".
 - Fit the device with the 50 cc syringe, ensuring the fin and plunger are in position.
 - Ensure the syringe is detected appropriately eg. **50cc**.
 - Place the syringe in the device ensuring the fin is out of the groove.
 - Fit the syringe clamp and plunger correctly.
 - Make sure the indicator alarm flashes, locating the problems on the syringe diagram.



4.3.22 Checking the anti-siphon arm



This check must be carried out for every syringe provided with the instrument.

- Check the functionality.
 - Free play, without end play or disassembly of this.
- Check for alarm presence with:
 - Anti-siphon arm in the upper position.
 - Anti-siphon arm in the lower position.

Ensure there is no alarm in presence of spacers or 20 cc and 50 cc syringes.

- Using spacers ref. T301518-A and T301519-B.
 - To carry out this operation, exit the test mode and press "OFF",
 - Press "ON".
 - Fit the instrument with the spacer ref T301518-A and lock it into position using the syringe clamp.
 - ♦ Place the plunger against the spacer with the anti-siphon arm on the spacer.
 - ♦ 20 c . c is displayed without triggering the alarm.
 - Fit the instrument with the spacer ref T301519-A and lock it into position using the syringe clamp.
 - ♦ Place the plunger against the spacer with the anti-siphon arm on the spacer.
 - ♦ 50 c . c is displayed without triggering the alarm.

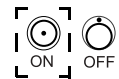

- Using 20cc and 50cc syringes.
 - To carry out this operation, exit the test mode and press "OFF",
 - Press "ON".
 - Fit the instrument with the 20 cc syringe and lock it into position using the syringe clamp.
 - ♦ Place the syringe plunger against the syringe with the anti-siphon arm on the syringe piston.
 - ♦ 20 c . c is displayed without triggering the alarm.
 - Fit the instrument with the 50 cc syringe and lock it into position using the syringe clamp.
 - ♦ Place the syringe plunger against the syringe with the anti-siphon arm on the syringe piston.
 - ♦ 50 c . c is displayed without triggering the alarm.



4.3.23 Checking the backpressure

To carry out this operation, exit the test mode and press "OFF",



*The instrument initialises the sensor once the plunger is disengaged.
The backpressure test must be performed with zero backpressure.*

- Press "ON".
 - Fit the instrument with the 50 cc syringe and lock it into position using the syringe clamp, ensuring the fin and plunger are correctly positioned.
 - Place the manometer (or any other pressure measurement device) at the syringe outlet.
 - Select a 50 ml "B-D PLASTIPAK" syringe by pressing "CONFIRM".
 - By pressing the "LIMIT PRESSURE" key, select a medium limit:
 - ♦ M (medium limit) = 500 mmHg \pm 75 or 0,65 bar \pm 0,1 bar.
 - Select a maximum flow rate and start the infusion by pressing the "CONFIRM" key.
 - ♦ Ensure there is no acoustic and visual alarm (backpressure Led off).
 - ♦ Check the infusion Leds are flashing.
 - ♦ Ensure the alarm is triggered for a value of 500 mmHg \pm 75 or 0,65 bar \pm 0,1 bar.
 - Stop the infusion cycle by pressing the "STOP INFUSION" key.

- Repeat this test selecting a higher limit by pressing the "LIMIT PRESSURE" key.:
 - ♦ H (high limit) = 900 mmHg \pm 150 or 1,2 bar \pm 0,2 bar.



4.3.24 Checking the end of infusion pre-alarm

To carry out this operation, exit the test mode and press "OFF",



■ Press "ON".

- Fit the device with the syringe, ensuring the fin and plunger are in position.
- Ensure the syringe is detected appropriately eg. **50 c.c.**
- Select a "B-D PLASTIPAK" syringe filled to 20 ml.
- Select a flow rate of 120 ml/hr.
 - ♦ For normal flow rates, the pre-alarm is activated 5 minutes before end of infusion.
 - ♦ Flow rate example: > 60 ml/hr, the pre-alarm is activated when the remaining volume equals 10% of the total syringe capacity.
 - ♦ Ensure the end of infusion pre-alarm is present.



- Press the "SILENCE ALARM" key.
 - ♦ The acoustic alarm is silenced and the visual signal is maintained.
- Measure the "hard height" distance at "end of infusion".
 - ♦ $18,5 \leq x \leq 19,5$.

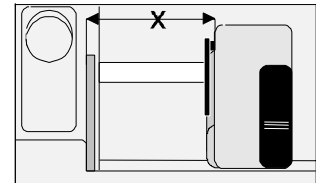

Top view



For accurate checking of the "hard height", do not move the plunger when measuring.

If the "hard height" reading is out of limits, recalibrate the position sensor (see "E L R.6 Position sensor calibration.").

4.3.25 Checking the limit volume programming

To carry out this operation, exit the test mode and press "OFF",



- Press "ON".
 - Fit the device with the syringe, ensuring the fin and plunger are in position.
 - Ensure the syringe is detected appropriately eg. **50 c.c.**
 - Select a "B-D PLASTIPAK" syringe filled to 20 ml.
 - Select a flow rate of 100 ml/hr on the display unit.
 - Select a limit volume of 10 ml.
 - ♦ Pre-alarm presence.
 - ♦ For normal flow rates, the pre-alarm is activated 5 minutes before end of infusion.
 - ♦ Flow rate example: > 60 ml/hr, the pre-alarm is activated when the remaining volume equals 10% of the total syringe capacity.
 - Press the "SILENCE ALARM" key
 - ♦ The acoustic alarm is silenced and the visual signal is maintained.



The limit volume alarm is activated when the programmed limit volume is reached. The device changes to KVO mode. flow rate of 1 ml/hr keeping the vein open.

- The pre-alarm is present when the KVO is activated.

4.3.26 Checking the linearity

To carry out this operation, exit the test mode and press "OFF",

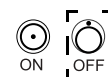

- Equipment required: Stop-clock, electronic calliper, BD Plastipak 50 ml. syringe.
- Press "ON".
 - Fit the device with the "B-D PLASTIPAK" 50 ml syringe, ensuring the fin and plunger are in starting position.
 - Measure the displacement X in mm.
- Ensure the syringe is detected appropriately eg. **50 c.c.**
- Select a "B-D PLASTIPAK" syringe filled to 50 ml.
- Select a flow rate of 50 ml/hr.
- Press "CONFIRM" to start infusion and simultaneously start the stop-clock
- At 50 minutes, stop the infusion by pressing "STOP" and measure the displacement X2.
- Ensure $X = X1 - X2$ lies between $74,96 \text{ mm} \leq X \leq 76,47 \text{ mm}$.

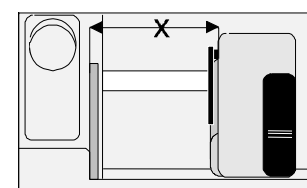
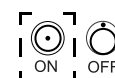

Top view



For accurate checking of the linearity do not move the plunger when measuring.

4.3.27 Checking the list of syringes

- *É* *S* *É* *H*, press "CONFIRM".
 - Upon start-up *S* *0* *c* *c* is displayed and the "50 ml" Led lights up.
 - Using the selection keys, a different syringe is shown on the display unit and is indicated by its Led.
 - ♦ Another possible capacity is *2* *0* *c* *c* corresponding to "20 ml".
 - ♦ The next part of the test concerns syringe details,
 - b* *d* *L* . = BD Plastipack,
 - b* *P* *F* . = BD Perfusion,
 - b* *r* *0* . = Braun Omnifix,
 - b* *r* *P* . = Braun Perfusor,
 - S* *n* *J* . = Sherwood Monoject,
 - t* *r* *n* . = Terumo.



4.3.28 Checking mains/battery operation

To carry out this operation, exit the test mode and press "OFF",

- Connect the device to a mains supply.
 - Check the operation of the mains presence Led (indicator in the shape of a plug).
- Connect the device to a test power supply.
 - Disconnect the device from the mains.
 - Remove the battery holder.
 - Remove the battery.
 - Remove the connection lugs.
 - Connect the battery lugs to a stabilised supply set at 6.3 V. Respect the polarities.
 - Press "ON".
 - Select a syringe from the syringe list proposed by the device.
- Press "CONFIRM"
- Select a flow rate and validate.
- Reduce the test power supply voltage until the battery discharge alarm is triggered.
 - ♦ Ensure this is triggered between 5.8 V and 6 V.



The acoustic alarm can be temporarily silenced by pressing "SILENCE ALARM" (2 minutes).



- Reduce the test power supply voltage again until the battery discharge alarm is triggered.
 - ♦ Ensure this is triggered between 5.6 V and 5.8 V.

If the results obtained during the tests differ from the values indicated, recalibrate the battery voltage levels (see "*É* *É* *R* . *4* Calibration of the 3 battery voltage levels.").

4.3.29 Battery autonomy test

- Recharge the battery for 16 hours.
- Perform an autonomy test of over 1 hour.
 - Fit the device with a B-D Plastipak 50 ml/hr syringe with a flow rate of 120 ml/hr (without Master module connections), then validate.
 - The "battery discharge" pre-alarm warns the user that an autonomy of 60 minutes at 5 ml/hr remains.
 - ◆ The "total battery discharge" alarm will sound before infusion stops completely.

4.3.30 Continuity test

Using a multimeter.

To carry out this operation, exit the test mode and press "OFF",

- Connect the multimeter to an ohmmeter.
 - Check the electrical resistance shown by the ohmmeter is over 10 M Ω :
 - ◆ between phase and metal tube.
 - ◆ between neutral and metal tube.



4.3.31 Regular inspection sheet

Use this table to note the results of the different tests.

Equipment type:	Code:	Equipment series N°:
-----------------	-------	----------------------

N°	Procedure	Resulting value	Conformity	
			Yes	No
1	■ Check the general condition of the case and its labels.			
2	■ Display total running time, <i>t 5 t 1</i> (in hours, days or months):*****			
3	■ Display the last servicing inspection date, <i>t 5 t 1</i> (in days, months or years):*****			
4	■ Check all indicator lights, <i>t 5 t 2</i> .			
5	■ Check the keyboard, <i>t 5 t 3</i> .			
6	■ Display the total running time, <i>t 5 t 6</i> (in hours, days or months):*****			
7	■ Check the force sensor, <i>t 5 t 9</i> : <input type="checkbox"/> On standby, check that the displayed value is <i>000.9 ± 100 g</i> : <input type="checkbox"/> Press and release the bonding pad, the value displayed should be <i>000.9 ± 100 g</i> : *****			
8	■ Check the ADC, <i>t 5 t b</i> : <input type="checkbox"/> Ensure the value of input 2 is: $066 \leq X \leq 08F$: *****			
9	■ Check the position sensor, <i>t 5 t c</i> : <input type="checkbox"/> High position with T300940 spacer, check that the displayed value is <i>115.0 ± 0.5 mm</i> : *****			
	<input type="checkbox"/> Low position with T300775 spacer, check that the displayed value is <i>20 .0 ± 0.5 mm</i> : *****			
10	■ Check the syringe clamp <i>t 5 t F</i> : <input type="checkbox"/> Syringe clamp in high position, check that the displayed value is <i>- - - . -</i> :*****			
	<input type="checkbox"/> Fit the device with a 50 cc syringe or a T301521 spacer, check that the value displayed is <i>50 c . c</i> :*****			
	<input type="checkbox"/> Fit the device with a 20 cc syringe or a T301521 spacer, check that the value displayed is <i>20 c . c</i> :*****			
	<input type="checkbox"/> Syringe clamp in low position, check that the displayed value is <i>- - - . -</i> :*****			
11	■ Check the list of programmed syringes, <i>t 5 t H</i> .			
12	■ Check the anti-siphon arm: <input type="checkbox"/> Free travel without end play. <input type="checkbox"/> Presence of the alarm in high and low position. <input type="checkbox"/> No alarm in presence of 20 cc and 50 cc syringe piston.			

N°	Procedure	Resulting value	Conformity	
			Yes	No
13	<ul style="list-style-type: none"> ■ Check the backpressure (use a Fresenius Vial dynamometer): <ul style="list-style-type: none"> □ 2nd segment of the LCD in 3-level mode, or 500 mmHg in standby mode $0.55 \leq X \text{ bar} \leq 0.75$: ***** 			
14	<ul style="list-style-type: none"> ■ Check the end of infusion pre-alarm: <ul style="list-style-type: none"> □ Eg.: for a flow rate of 50 ml/hr with a 60 cc BD, check that the pre-alarm is triggered at $5 \text{ mn} \pm 10 \text{ s}$ before the end of infusion: ***** 			
15	<ul style="list-style-type: none"> ■ Check the end of infusion alarm: <ul style="list-style-type: none"> □ With a 60 cc BD, check that the hard height distance is $18,5 \leq x \text{ mm} \leq 19,5$: ***** 			
16	<ul style="list-style-type: none"> ■ Check the linearity (60 cc BD Plastipack): <ul style="list-style-type: none"> □ Measure the plunger distance, X1 mm: ***** □ Measure the plunger distance after 50 mn pump running, X2 mm:..... □ Ensure $74.96 \leq X1-X2 \text{ mm} \leq 76.47$:***** 			
17	<ul style="list-style-type: none"> ■ Check the battery autonomy: <ul style="list-style-type: none"> □ Recharge the battery for 16 hours. □ Operate the Pilot for 1 hr at a flow rate of 120 ml/hr:***** 			
18	<ul style="list-style-type: none"> ■ Carry out the electrical tests according to standard EN 60601-1 			

Name:	Date:	Signature:
-------	-------	------------

Comments:

4.4 Flow rate control

4.4.1 Measurement with a computer

ISDébit software is required for measuring the flow with a computer. This software is the property of **Fresenius Vial**. Please contact our After Sales Service for any further information.

The operation mode defined by this software follows the project protocol of standard PrEN-60-601-2-24 for **infusion pumps**. It is up to the user to adapt this procedure to the software used.



*In order to purchase the ISDébit flow rate control software, contact the **Fresenius Vial** customer service.*

The test procedure defined below must be carried out using a 50 ml or 20 ml syringe.

Equipment required

- Scales coupled to a microcomputer:

Flow rate value	Scales sensitivity
$x \leq 5$ ml/hr	1/10000th
5 ml/hr $< x \leq 30$ ml/hr	1/1000th
$x > 30$ ml/hr	1/100th

- Multi scales acquisition programme.
- Test tube or beaker with 1 ml graduating
- Liquid: distilled water and oil
- Luer lock type plastic syringe (50 or 20 ml).
- Catheter extension with Luer Lock (length 100 cm, inside diameter 2,5 mm).
- Needle:

Flow rate value	Needle type
$x \leq 30$ ml/hr	G26
$x > 30$ ml/hr	G18 or G21

Installation

- According to the installation drawings shown below.

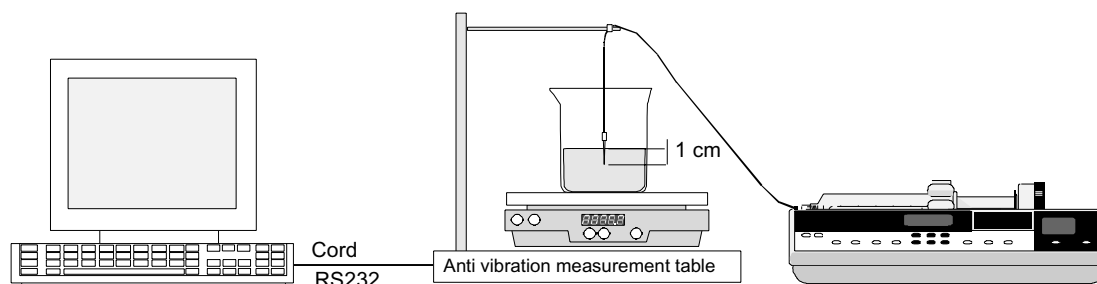

Make sure the horizontal installation plane is respected.

- Fill the syringe with 50 ml of distilled water.
 - Prime to eliminate any air bubbles.
- Secure the female Luer Lock end piece of the catheter extension onto the syringe and the male Luer lock end piece onto the needle.
- Fit the syringe onto the device.
- Fill the test tube ensuring the needle is dipped in the liquid (> 1 cm).
 - Add several drops of oil to create a greasy film on the surface of the liquid. This way the user will avoid any measurement error due to evaporation of the liquid.
- Place the test tube in the centre of the scales platform.
- Place the needle inside the test tube.

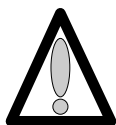

The infusion line (needle/catheter extension) must not rest on the scales/test tube assembly.

- Press "ON" (device in mains supply mode).
 - Prime the infusion line using the "BOLUS" key.
 - Check that there are no air bubbles.



Operating mode



*The software works following the operating mode described in the PrEN-60-601-2-24 standard project for **infusion pumps**.*

- Start the acquisition programme for the scales.
- Enter the necessary data to launch the programme without validating the flow rate.
- Adjust the scales to the specified flow rate.
- Confirm the flow rate on the microcomputer so that the automatic setting of the scales can take place.
- Start the infusion by pressing the "CONFIRM" key, when **00.00** appears on the scales display screen.
- When the specified time is over, note the error percentage displayed on the screen.



4.4.2 Measurement with scales

Equipment required

- Stop clock
- Scales

Flow rate value	Scales sensitivity
$x \leq 5$ ml/hr	1/10000th
5 ml/hr $< x \leq 30$ ml/hr	1/1000th
$x > 30$ ml/hr	1/100th

- Test tube or beaker with 1 ml graduating
- Liquid: distilled water and oil
- Luer lock type plastic syringe (50 or 20 ml)
- Catheter extension with Luer Lock (length 100 cm, inside diameter 2,5 mm).
- Needle:

Flow rate value	Needle type
$x < 30$ ml/hr	G26
$x > 30$ ml/hr	G18 or G21

Installation

- According to the installation drawings shown below.

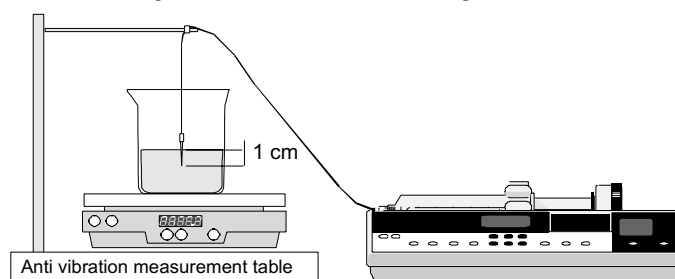

Make sure the horizontal installation plane is respected.

- Fill the syringe with 50 ml of distilled water.
- Prime to eliminate any air bubbles.
- Secure the female Luer Lock end piece of the catheter extension onto the syringe and the male Luer lock end piece onto the needle.
- Fit the syringe onto the device.
- Fill the test tube ensuring the needle is dipped in the liquid (> 1 cm).
- Add several drops of oil to create a greasy film on the surface of the liquid. This way the user will avoid any measurement error due to evaporation of the liquid.
- Place the test tube in the centre of the scales platform.
- Place the needle inside the test tube.



The infusion line (needle/catheter extension) must not rest on the scales/test tube assembly.

- Press "ON" (device in mains supply mode).
 - Prime the infusion line using the "BOLUS" key.
 - Check that there are no air bubbles.

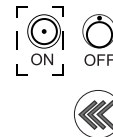

Operating mode

- Select a flow rate.



For low flow rates (< 5 ml/hr), validate and wait for the infusion to stabilise for 1 hour. For higher flow rates, wait for 10 to 30 minutes after infusion.

- Set the scales at **00.00** g.
- Start infusion by pressing the "CONFIRM" key, and start the stop clock at the same time, (if necessary make a note of the stop clock start value).
- Press the "STOP INFUSION" key to stop the test one hour later.
- Note the value in grams of the "infused" liquid.
- Calculate the difference between the design value and the real value.



1 gram = 1 ml.

- The error percentage can be calculated from this difference :

$$\frac{(\text{Real value} - \text{Design value})}{\text{Design value}} \times 100 = \text{Error percentage}$$

4.4.3 Measurement using a test tube

Equipment required

- Stop clock.
- Test tube or beaker with 1 ml graduating
- Liquid: distilled water and oil
- Luer lock type plastic syringe (50 or 20 ml)
- Catheter extension with Luer Lock (length 100 cm, inside diameter 2,5 cm).
- Needle:

Flow rate value	Needle type
x < 30ml/hr	G26
x > 30 ml/hr	G18 or G21

Installation

- According to the installation drawings shown below.

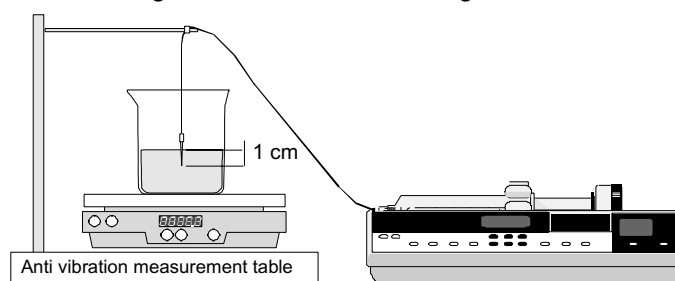

Make sure the horizontal installation plane is respected.

- Fill the syringe with 50 ml of distilled water.
 - Prime to eliminate any air bubbles.
- Secure the female Luer Lock end piece of the catheter extension onto the syringe and the male Luer lock end piece onto the needle.
- Fit the syringe onto the device.
- Fill the test tube ensuring the needle is dipped in the liquid (> 1 cm).
 - Add several drops of oil to create a greasy film on the surface of the liquid. This way the user will avoid any measurement error due to evaporation of the liquid.
 - Place the needle inside the test tube.

Operating mode

- Select a flow rate.



For low flow rates (< 5 ml/hr), validate and wait for the infusion to stabilise for 1 hour. For higher flow rates, wait for 10 to 30 minutes after infusion.

- Start infusion by pressing the "CONFIRM" key, and start the stop clock at the same time, (if necessary make a note of the stop clock start value).
- Once the whole infused syringe is in the test tube, calculate the difference between the design value and the real value:
Real flow rate = 50 ml/time in hours
- The error percentage can be calculated from this difference :

$$\frac{(\text{Real value} - \text{Design value})}{\text{Design value}} \times 100 = \text{Error percentage}$$



4.5 Cleaning and disinfection

The syringe pump is part of the patient's immediate environment. It is advisable to clean and disinfect the external surfaces of the device on a daily basis in order to protect both patient and personnel from any risks of contamination.

- Disconnect the power cable from the wall socket before cleaning.
- Do not place in an AUTOCLAVE or IMMERSE the device, and do not allow liquid to penetrate inside the equipment case or power supply cover.
 - Use a cloth soaked in DETERGENT-DISINFECTANT, diluted in water if necessary, to eliminate micro organisms.
 - Avoid excessively abrasive brushing that could scratch the case.
 - Do not rinse or wipe the surfaces.
- If the equipment is used in a department with severe contamination risks, after disinfecting by wiping with a damp cloth, equipment should be left in the room during aerial disinfection.

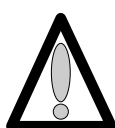

Do not use TRICHLOROETHYLENE-DICHLOROETHYLENE.

- "TRICHLOROETHYLENE-DICHLOROETHYLENE:
 - AMMONIA.
 - AMMONIUM CHLORIDE
 - CHLORINE AND AROMATIC HYDROCARBON.
 - ETHYLENE DICHLORIDE-METHYLENE CHLORIDE
 - CETONE based cleaning products.

These aggressive agents could damage the plastic parts and lead to apparatus malfunctions.

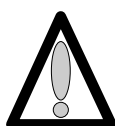

Also beware of ALCOHOL SPRAYS (20% -40% alcohol) that tarnish and crack the plastic and fail to provide the cleaning action required prior to disinfection.

For further information, please contact the competent department in your hospital for supply of the appropriate cleaning and disinfecting products.

4.6 Storage

In case of prolonged storage, it is advisable to disconnect the battery using the battery access door on the bottom of the device. This operation should be done by an experienced technician.

The equipment must be stored in a dry and cool place.

- The recommended environmental temperature conditions for storage of the equipment are between 0°C and 40°C.
- Relative humidity tolerated: max. 85%, no condensation.

Fully recharge the battery before using the equipment to avoid any risks caused by micro power cuts in the mains supply and to ensure maximum autonomy.

5 Diagnosis

5.1 Troubleshooting

Problem	Cause	Solution
End of infusion detected too early (at approximately 10 ml).	<ul style="list-style-type: none"> ■ The syringe used does not correspond to the selected one. 	<ul style="list-style-type: none"> ■ Change the syringe.
No pre-alarm or alarm at end of infusion.		
Too much flow rate or displacement control drift.		
Occlusion alarm upon start-up	<ul style="list-style-type: none"> ■ Inappropriate calibration of the force sensor. 	<ul style="list-style-type: none"> ■ Recalibrate the force sensor (see "E t R.9 Force sensor calibration.").
	<ul style="list-style-type: none"> ■ Force sensor out of order. 	<ul style="list-style-type: none"> ■ Check the force sensor (see "E t R.9 Force sensor calibration.").
	<ul style="list-style-type: none"> ■ Ribbon cable cut. 	<ul style="list-style-type: none"> ■ Replace the ribbon cable (see "Ribbon cable winding kit" operation sheet).
Occlusion alarm during operation.	<ul style="list-style-type: none"> ■ Pressure limit selected is too low. 	<ul style="list-style-type: none"> ■ Select a medium pressure limit.
	<ul style="list-style-type: none"> ■ Inappropriate calibration of the force sensor. 	<ul style="list-style-type: none"> ■ Recalibrate the force sensor (see "E t R.9 Force sensor calibration.").
	<ul style="list-style-type: none"> ■ Ribbon cable cut. 	<ul style="list-style-type: none"> ■ Replace the ribbon cable (see "Ribbon cable winding kit" operation sheet).
Disengagement alarm upon start-up	<ul style="list-style-type: none"> ■ Faulty disengagement micro-switch. 	<ul style="list-style-type: none"> ■ Replace the micro-switch (see "Syringe detection system" operation sheet)
Syringe piston detection alarm not justified.	<ul style="list-style-type: none"> ■ Faulty photoelectric cell and/or syringe piston obturator. 	<ul style="list-style-type: none"> ■ Check the syringe clamp (see "Checking the syringe clamp").
Syringe body clamp alarm not justified.		
Syringe fin detection alarm not justified.	<ul style="list-style-type: none"> ■ Faulty switch and/or fin detection connections. 	<ul style="list-style-type: none"> ■ Check the fin detection system 'see "Checking the fin detection system").
Display fault: segments, Leds	<ul style="list-style-type: none"> ■ Control transistors and/or display board connections. 	<ul style="list-style-type: none"> ■ Check the display (see "Checking the indicator lights"). ■ Check the connectors.
After a fall.	<ul style="list-style-type: none"> ■ Damaged mechanical elements. 	<ul style="list-style-type: none"> ■ Check that the input bearing and mechanical assembly are intact.

5.2 Error messages

Error code	Description	Recommended action
Electronic control and software* anomalies		
<i>Er 10</i>	<ul style="list-style-type: none"> Internal RAM anomaly. 	<ul style="list-style-type: none"> Reconfigure the Pilot (see "Current operation parameter configuration menu").
<i>Er 20</i>	<ul style="list-style-type: none"> External RAM anomaly. 	
<i>Er 30</i>	<ul style="list-style-type: none"> EEPROM anomaly. 	
<i>Er 40</i>	<ul style="list-style-type: none"> EEPROM anomaly. 	
<i>Er 50</i>	<ul style="list-style-type: none"> ADC anomaly. 	<ul style="list-style-type: none"> Check the ADC (see "Checking the ADC").
<i>Er 60</i>	<ul style="list-style-type: none"> Syringe parameter anomaly. 	<ul style="list-style-type: none"> Reconfigure the Pilot (see "Current operation parameter configuration menu")
<i>Er 70</i>	<ul style="list-style-type: none"> Motor frequency anomaly. 	
<i>Er 80</i>	<ul style="list-style-type: none"> Faulty keyboard. Short circuit in the keyboard. 	<ul style="list-style-type: none"> Check the keyboard.
	<ul style="list-style-type: none"> Electromagnetic disturbance exceeding standard limits. 	<ul style="list-style-type: none"> Check the operation environment of the Pilot.

*: When rewriting the EEPROM, when the device is switched off, the Check Sum is rewritten in the memory to save the parameters.

If the Hard cut-off circuit is shorter in time than the Soft circuit, the device is switched off before the EEPROM is fully rewritten: Check Sum not compliant.

Err(-)0 or CFPc: When the device is in CFPc, reconfiguration is compulsory: Faulty WATCH DOG.

Motor anomalies

<i>Er 01</i>	<ul style="list-style-type: none"> Motor control failure. Motor fault. 	<ul style="list-style-type: none"> Check the motor power supply. Replace the motor.
--------------	--	---

Plunger advance anomalies

<i>Er 32</i>	<ul style="list-style-type: none"> Anomaly over a short distance. 	<ul style="list-style-type: none"> Check the connectors. Check that the potentiometer is tightened. Check the ADC (see "Checking the ADC"). Check the position sensor (see "Checking the position sensor").
<i>Er 52</i>	<ul style="list-style-type: none"> Anomaly during compensation for play. 	
<i>Er 72</i>	<ul style="list-style-type: none"> Anomaly over the whole length. 	
<i>Er 82</i>	<ul style="list-style-type: none"> Anomaly in relation to the flow rate. 	

Error code	Description	Recommended action
Calculation parameter anomalies (motor and flow rate)		
<i>Er 14</i>	■ Motor period calculation anomaly.	<ul style="list-style-type: none"> ■ Check the ADC (see "Checking the ADC"). ■ Check the position sensor (see "Checking the position sensor.").
<i>Er 24</i>	■ Motor rotation direction anomaly.	
<i>Er 34</i>	■ Flow rate/period calculation anomaly.	
<i>Er 44</i>	■ UART and micro-controller crystal frequency anomaly.	
Configuration anomalies		
<i>CFPc</i>	■ The configuration self-test upon start-up was not satisfactory.	■ Reconfigure the Pilot (see "Pressure parameter configuration menu" and "Current operation parameter configuration menu").

6 Operation sheets

This chapter lists the set of dismounting/remounting sheets.

N°1, Procedure: Display and central unit boards

Safety:

For safety reasons, the technician should not carry out any maintenance when the device is connected to the 230 V mains supply voltage.

Disconnect the mains power supply cable.

Equipment required:

- 1 Posidriv Z1 screwdriver.
- 1 antistatic wriststrap.

Maintenance level:

Level 2, specialised technician (see documentation on biomedical training).

Procedure:

Access

- Turn the **Pilot** over onto the upper case.
- Unscrew the 6 Phillips head screws (ref. 1) located at the bottom of the lower case, which link this to the upper case.
- Keep the **Pilot** assembled and turn it over onto the lower case.
- Remove the upper case making sure the CPU board flat jumper is not accidentally removed in the process.
- Disconnect the CPU board flat jumper.

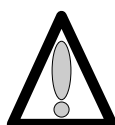

Hands must not come into contact with the CPU boards.

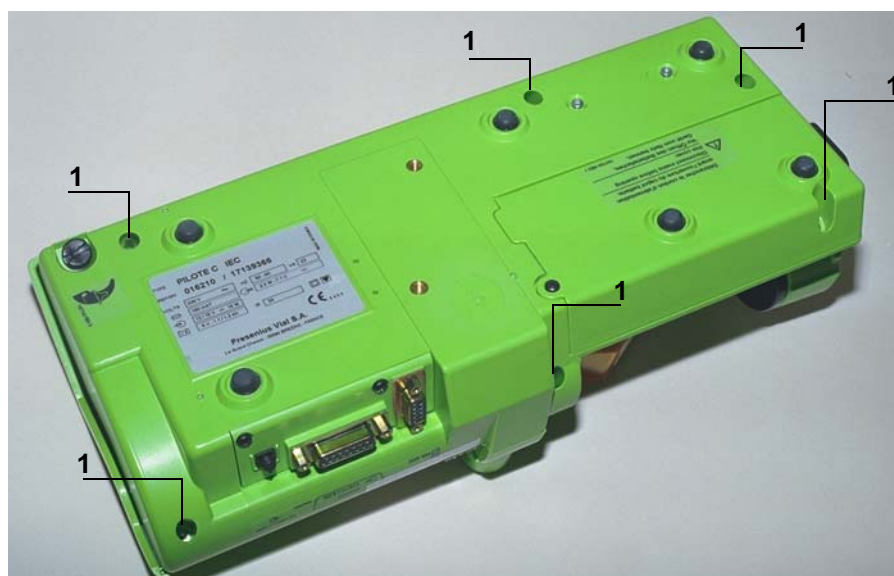

Dismounting



When electronic components are handled, it is recommended to wear an antistatic wriststrap linked to ground and to work on an antistatic foam mat.

- Unscrew the 5 Phillips head screws (ref. 2) located at the display board, which link this to the upper case.
- Remove the board insulator (ref. 3) located on the left.
- Lift the display board slightly and remove the display unit flat jumper (ref. 4).
- Disconnect the black connector (ref. 5).

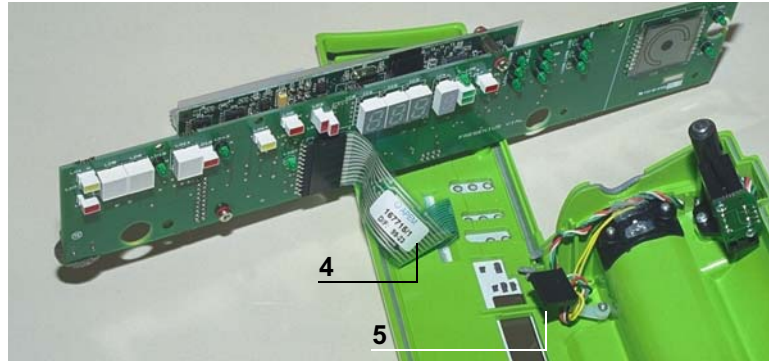
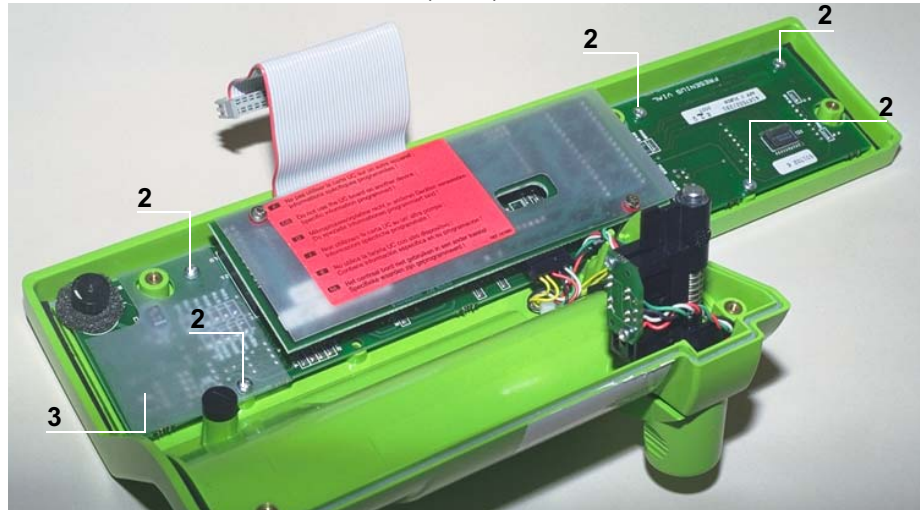

Remounting



*A specific type of board corresponds to each **Pilot** "CPU and display board" ; It is important to avoid reversing the references between each **Pilot** and order the part number corresponding to your device.*

Carry out the same procedures in reverse to reassemble the parts.



When mounting the display board, it is important to reduce the torque in the plastic inserts so as to avoid causing damage to these.

When fitting the upper case, ensure the joint is perfectly positioned in its slot after reassembly.

Recalibrate the **Pilot** (see "Calibrations") then carry out the regular servicing tests (see "Regular servicing sheet").

N°2, Procedure: Syringe clamp

Safety:

For safety reasons, the technician should not carry out any maintenance when the device is connected to the 230 V mains supply voltage.

Disconnect the mains power supply cable.

Equipment required:

- 1 Posidriv Z1 screwdriver.
- 1 Posidriv Z1 flat screwdriver.

Maintenance level:

Level 2, specialised technician (see documentation on biomedical training).

Procedure:

Access

- Turn the Pilot over onto the upper case.
- Unscrew the 6 Phillips head screws (ref. 1) located at the bottom of the lower case, which link this to the upper case.
- Keep the Pilot assembled and turn it over onto the lower case.
- Remove the upper case making sure the CPU board flat jumper is not accidentally removed in the process.
- Disconnect the CPU board flat jumper.

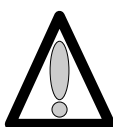

Hands must not come into contact with the CPU boards.

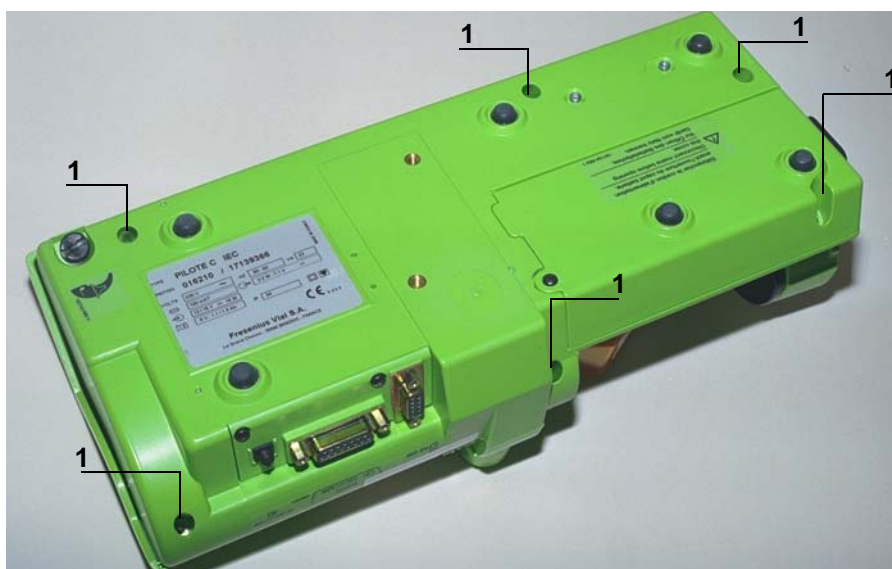

Dismounting

- Remove the spring retaining ring (ref. 2) located on the syringe clamp shaft, which holds this to the CPU support.
- Remove the obturator and the spring (ref. 3).
- Remove the syringe clamp.

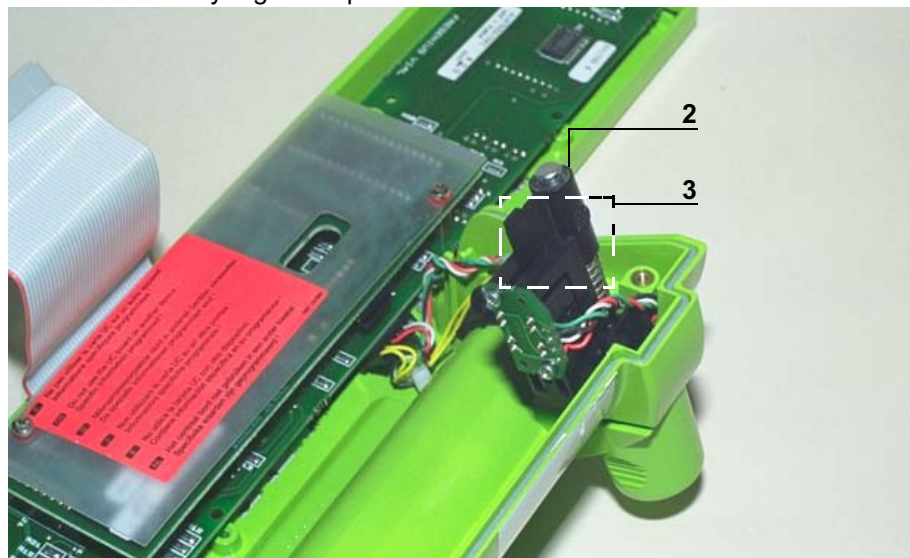

Reassembly

Carry out the same procedures in reverse to remount the unit.



When fitting the upper case, ensure the joint is perfectly positioned in its slot after reassembly.

Perform the regular servicing tests (see "Regular servicing sheet").

N°3, Procedure: Syringe detection system

Safety:

For safety reasons, the technician should not carry out any maintenance when the device is connected to the 230 V mains supply voltage.

Disconnect the mains power supply cable.

Equipment required:

- 1 Posidriv Z1 screwdriver.
- 1 antistatic wriststrap.
- 1 soldering iron
- "RADIEL Sn60Pb RI 1" welding wire (cleaning not required for rewelding) or equivalent.
- Silicone ref. 161249.

Maintenance level:

Level 2, specialised technician (see documentation on biomedical training).

Switch replacement procedure:

Access

- Turn the **Pilot** over onto the upper case.
- Unscrew the 6 Phillips head screws (ref. 1) located at the bottom of the lower case, which link this to the upper case.
- Keep the **Pilot** assembled and turn it over onto the lower case.
- Remove the upper case making sure the CPU board flat jumper is not accidentally removed in the process.
- Disconnect the CPU board flat jumper.

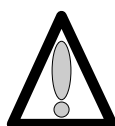

Hands must not come into contact with the CPU boards.

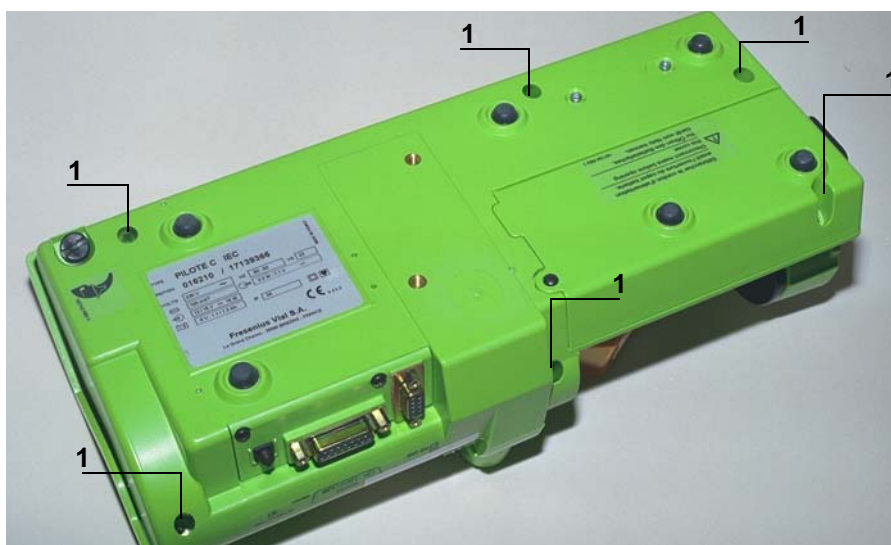

Dismounting

- Disconnect the connector (ref. 2).
- Unscrew the Phillips head screw (ref. 3) which holds the conductor to the upper case.
- Unscrew the 2 Phillips head screws (ref. 4) which hold the switch support in position.
- Remove the switch assembly.
- Remove the silicone pins.

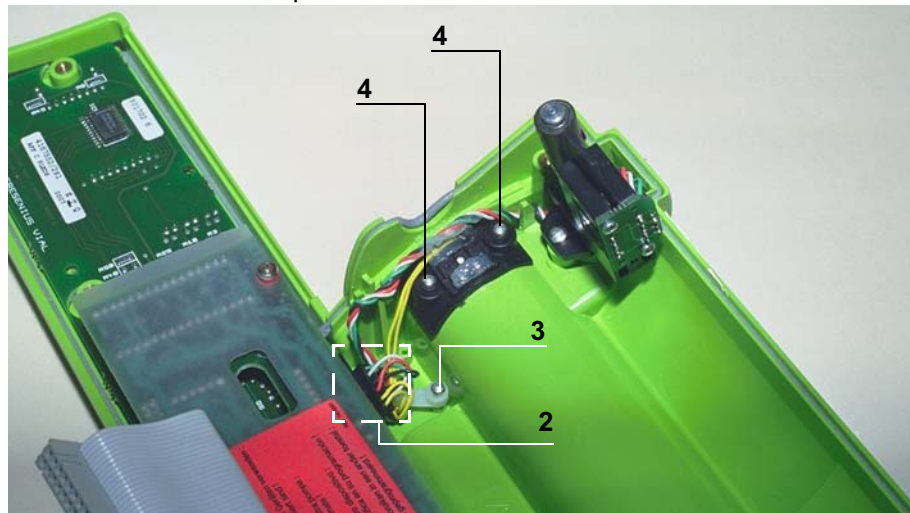

Welding and unwelding operations are carried out using a soldering iron fitted with a tip in good condition, constantly tapered and clean kept. The temperature of the iron should be between 315°C and 340°C.

- Unweld the switch wires:
 - Add more weld to facilitate the unwelding process.
 - Heat and pull on the wires one by one.
 - Straighten up the 4 mounting lugs and remove the switch.

Reassembly

- Place the new switch on the support.
- Bend the mounting lugs towards the inside in order to lock them into position.
- Weld the wires of the new switch:
 - Taper the 2 welding wires and the 2 lugs of the switch to be welded.
 - Place the wires under the bent lugs.
 - Place the welding iron tip on the welding surface.
 - Place the welding wire on the pin surface of the switch to be welded.
 - Remove the welding wire and then the welding iron tip.
 - Check that the welding has been carried out correctly. It should not form a ball, but should lie against the length of the wire.
- Screw the 2 Phillips head screws (ref. 3) which hold the "switch support" assembly in position.



When mounting the "switch support", it is important to reduce the torque in the plastic inserts so as to avoid causing damage to these.

- Connect the conductor to the CPU board.
 - Tighten the Phillips head screw holding the conductor (ref. 2).
 - Place 2 silicone pins on the switch contacts in order to insulate these.
- Carry out the same procedures in reverse to remount the unit.



When fitting the upper case, ensure the joint is perfectly positioned in its slot after reassembly.

Perform the regular servicing tests (see "Regular servicing sheet").

Opto replacement procedure:

Access

- Turn the **Pilot** over onto the upper case.
- Unscrew the 6 Phillips head screws (ref. 1) located at the bottom of the lower case, which link this to the upper case.
- Keep the **Pilot** assembled and turn it over onto the lower case.
- Remove the upper case making sure the CPU board flat jumper is not accidentally removed in the process.
- Disconnect the CPU board flat jumper.

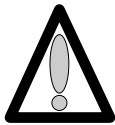

Hands must not come into contact with the CPU boards.

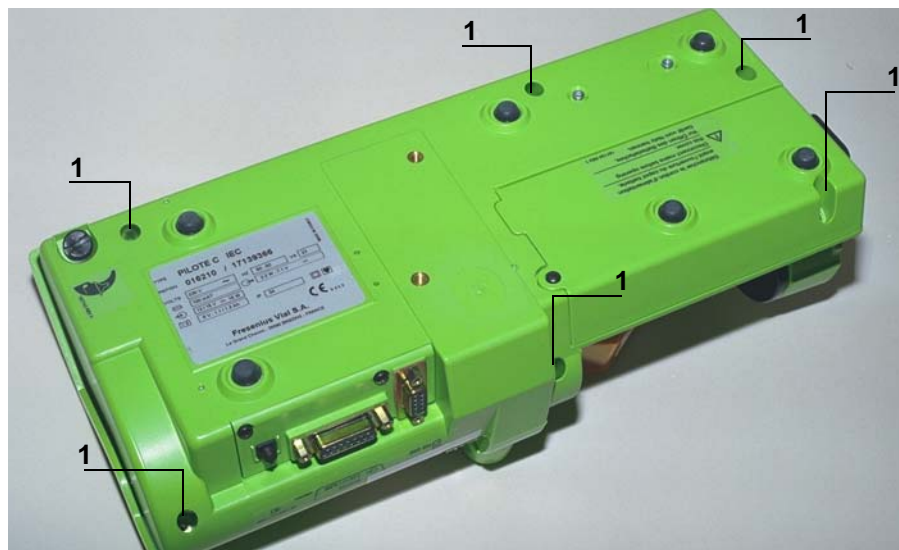

Dismounting

- Disconnect the connector (ref. 2).
- Unscrew the Phillips head screw (ref. 3) which holds the conductor to the upper case.
- Unscrew the 2 Phillips head screws (ref. 5) which hold the opto PCB in position.
- Remove the opto assembly.

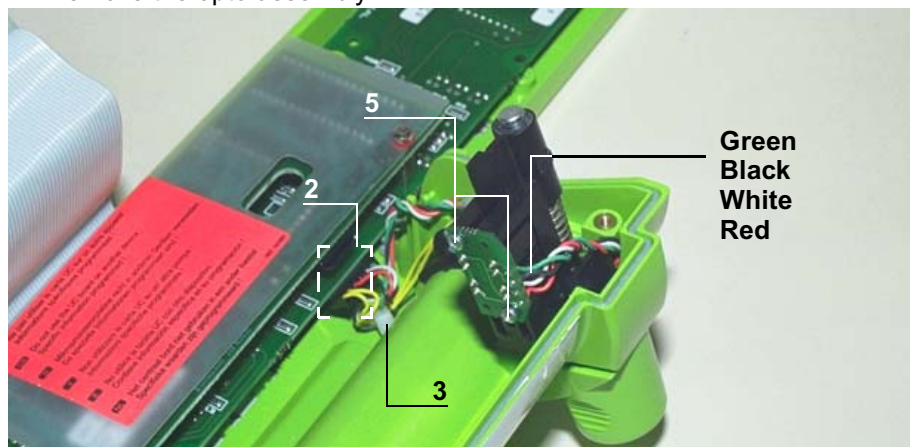

Reassembly

- Place the new opto assembly on the PCB support.
- Screw the 2 Phillips head screws (ref. 5) which hold the "PCB and opto" assembly in position.



When mounting the "PCB and opto", it is important to reduce the torque in the plastic inserts so as to avoid causing damage to these.

- Connect the conductor to the CPU board.
 - Tighten the Phillips head screw holding the conductor (ref. 2).
- Carry out the same procedures in reverse to remount the unit.



When fitting the upper case, ensure the joint is perfectly positioned in its slot after reassembly.

Perform the regular servicing tests (see "Regular servicing sheet").

N°4, Procedure: Motor + Opto + Disk

Safety:

For safety reasons, the technician should not carry out any maintenance when the device is connected to the 230 V mains supply voltage.

Disconnect the mains power supply cable.

Equipment required:

- 1 Posidriv Z1 screwdriver.
- 1 antistatic wriststrap.

Maintenance level:

Level 2, specialised technician (see documentation on biomedical training).

Procedure:

Access

- Turn the Pilot over onto the upper case.
- Unscrew the 6 Phillips head screws (ref. 1) located at the bottom of the lower case, which link this to the upper case.
- Keep the Pilot assembled and turn it over onto the lower case.
- Remove the upper case making sure the CPU board flat jumper is not accidentally removed in the process.
- Disconnect the CPU board flat jumper.

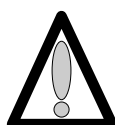

Hands must not come into contact with the CPU boards.

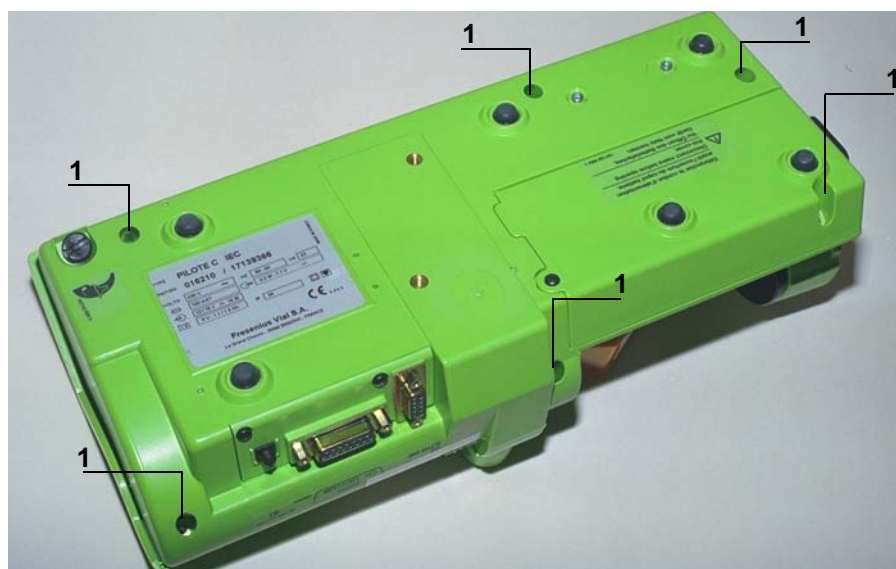

Dismounting

- Press the syringe pump disengagement lever towards the back of the Pilot as far as possible.
- Maintain this position and slide the whole unit to the back left.
- Remove the plunger guide.
- Disconnect the black connectors (ref. 2).
- Unscrew the flat jumper mounting lug (ref. 3) without removing it.
- Remove the mechanical plunger unit from its slot.
- Disconnect the blue connector from the flat jumper (ref. 4).
- Remove the mechanical plunger unit.

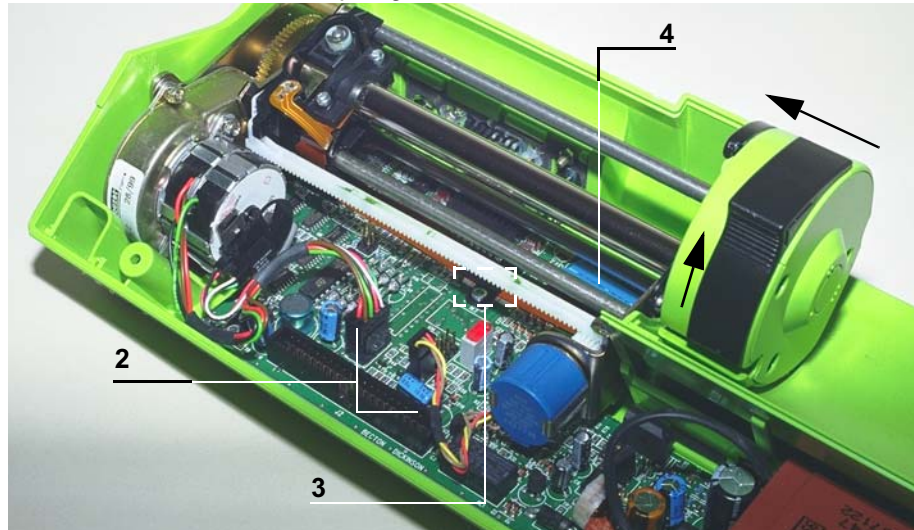

- Unscrew the 2 Phillips head screws (ref. 5).
- Remove the motor, opto and disk assembly.

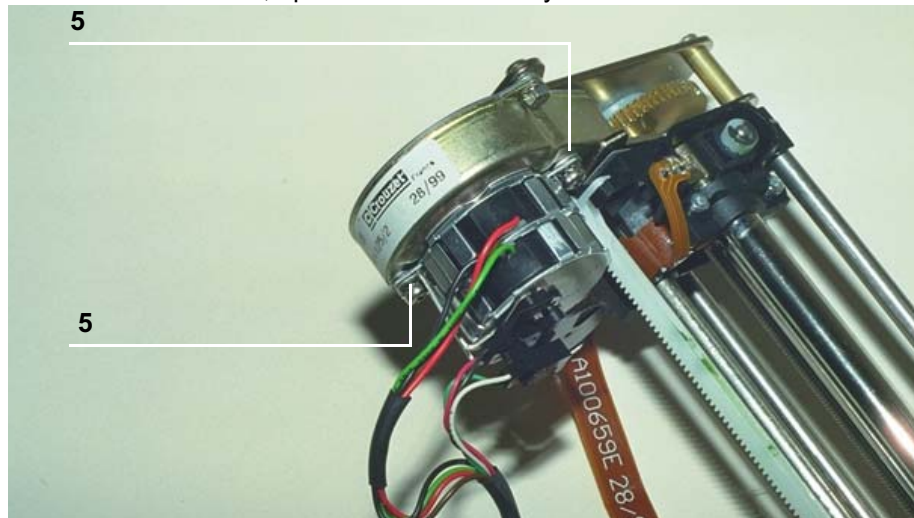

Reassembly

Carry out the same procedures in reverse to remount the unit.



When fitting the upper case, ensure the joint is perfectly positioned in its slot after reassembly.

Perform the regular servicing tests (see "Regular servicing sheet").

N°5, Procedure: Pressure sensor

Safety:

For safety reasons, the technician should not carry out any maintenance when the device is connected to the 230 V mains supply voltage.

Disconnect the mains power supply cable.

Equipment required:

- 1 Posidriv Z1 screwdriver.
- 1 hexagon socket key (2.5).
- 1 soldering iron.
- "RADIEL Sn60Pb RI 1" welding wire (cleaning not required for rewelding) or equivalent.

Maintenance level:

Level 2, specialised technician (see documentation on biomedical training).

Procedure:

Access

- Turn the **Pilot** over onto the upper case.
- Unscrew the 6 Phillips head screws (ref. 1) located at the bottom of the lower case, which link this to the upper case.
- Keep the **Pilot** assembled and turn it over onto the lower case.
- Remove the upper case making sure the CPU board flat jumper is not accidentally removed in the process.

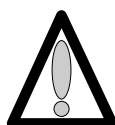

Hands must not come into contact with the CPU boards.

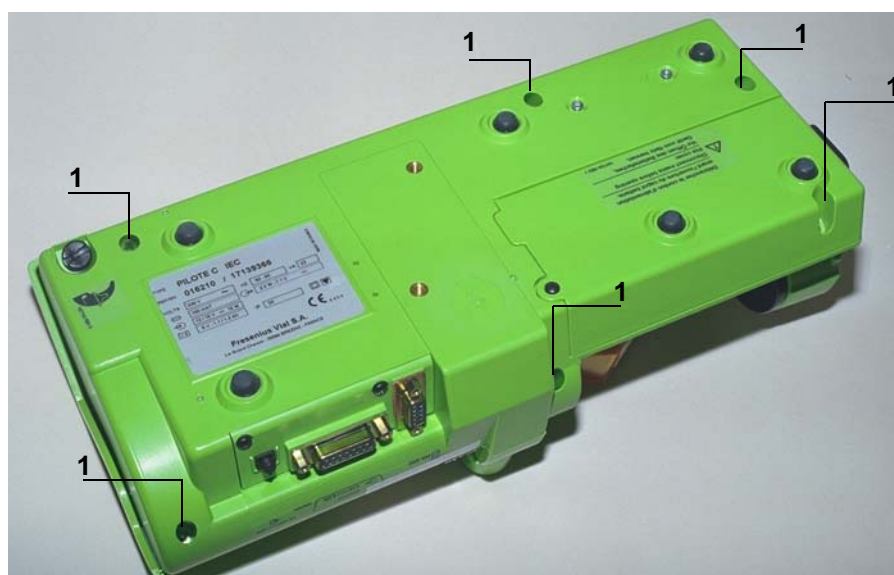

Dismounting

- Press the syringe pump disengagement lever towards the back of the Pilot as far as possible.
- Maintain this position and slide the whole unit to the back right.
- Remove the plunger guide.
- Unscrew the 3 Phillips head screws (ref. 2) located at the bottom of the plunger end shield which link this to the plunger cover.

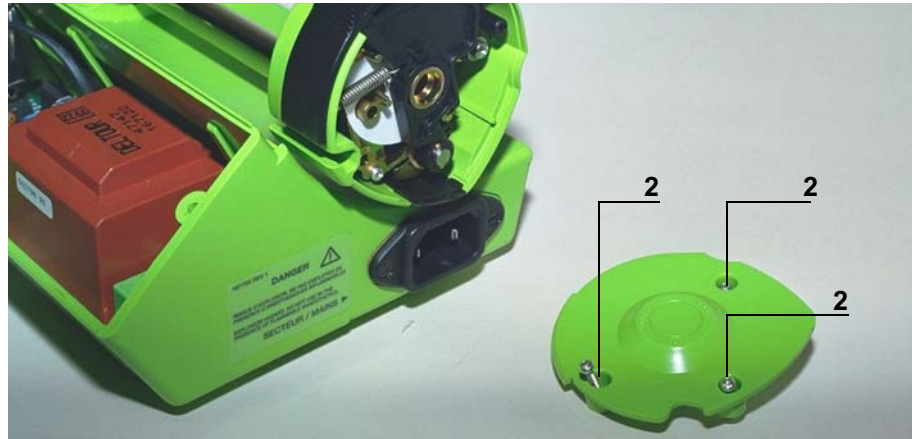

- Remove the plunger end shield, the disengagement lever and its spring (ref. 3) as well as the protective plunger film (ref. 4).
- Remove the plunger cover clip (ref. 5).

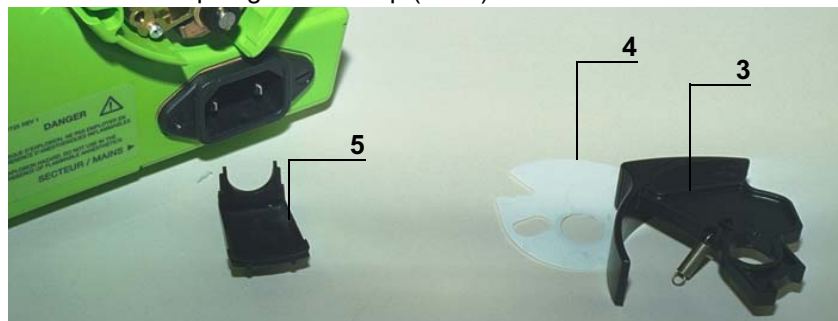

- Unscrew the 2 Phillips head screws (ref. 6 and 7) which link the plunger support to the plunger cover.
- Unscrew and remove the Phillips head screw and the washer (ref. 8) which attach the anti-siphon cam to the anti-siphon arm.
- Remove the cam/arm unit as well as the plunger cover.

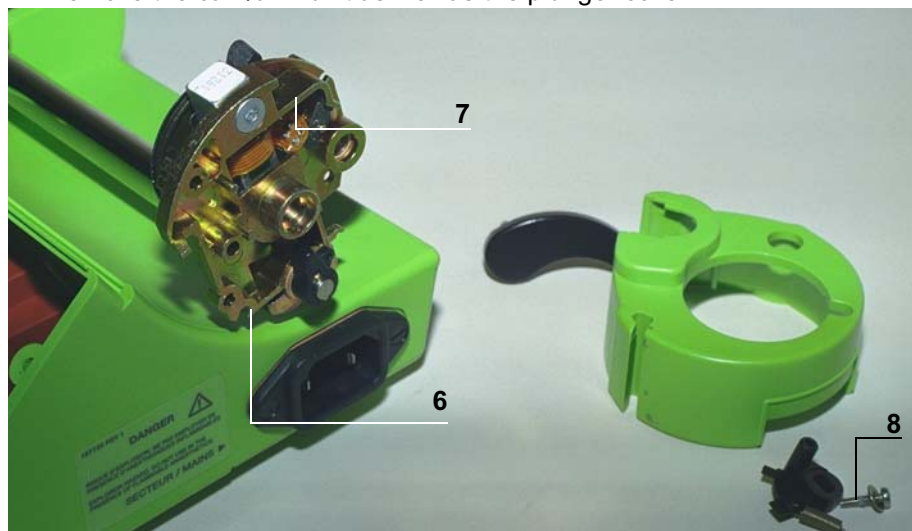

- Remove the bonding pad label.
- Unscrew the 6 hexagon socket screws (ref. 9) and remove the bonding pad.
- Unscrew the 6 hexagon socket screws (ref. 10) and remove the force sensor.

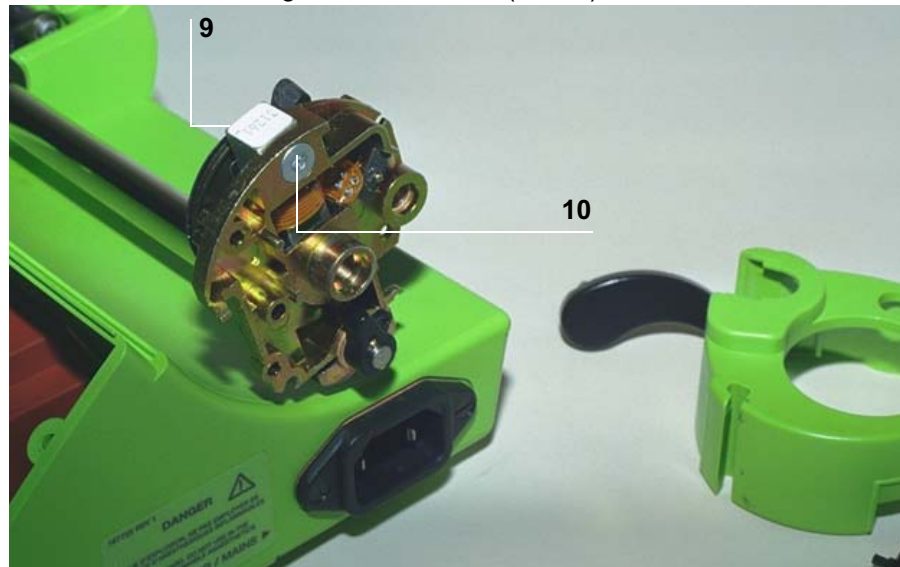

Welding and unwelding operations are carried out using a soldering iron fitted with a tip in good condition, constantly tapered and clean kept.. The temperature of the iron should be between 315°C and 340°C.

- Unweld the sensor wires on the flex circuit:



When dismantling the force sensor, ensure the welding pellets are not damaged.

- Add more weld to facilitate the unwelding process.
- Heat and pull on the wires one by one.

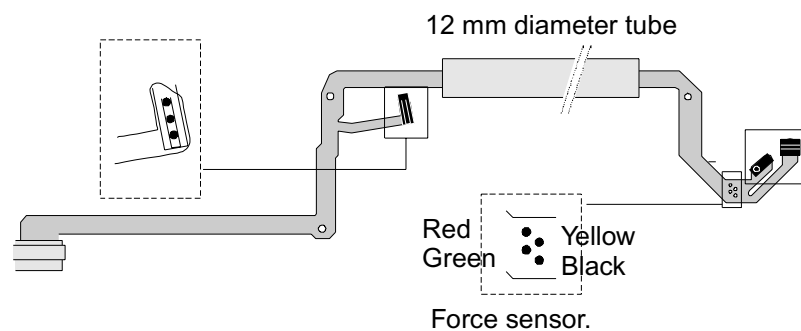

Reassembly

- Weld the wires to the new sensor, respecting the colour code.
 - Taper the 4 welding wires.
 - Weld the 4 wires.
 - Check that the welding has been carried out correctly. It should not form a ball, but should lie against the length of the wire.
- Impregnate with weak loctite and screw the 6 hexagon socket screws (ref. 10) which attach the sensor to the plunger support.
- Impregnate with weak loctite and screw the 6 hexagon socket screw (ref 9) which hold the new force sensor to the bonding pad.
- Mount the plunger cover onto the plunger support.
- Centre the bonding pad in relation to the plunger cover and lock the bonding pad/sensor unit into position on the plunger support.
- Check the free movement of the removable stop plate.



- Impregnate the screw with weak loctite (ref. 8).
 - Position and screw the cam/anti-siphon arm unit using the Phillips head screw and the washer (ref. 8).
 - Screw the 2 Phillips head screws (ref. 7 and 6) which link the plunger support to the plunger cover.
 - Position the plunger cover clip (ref. 5).
 - Cover the plunger with the protective film, mount the disengagement lever and its spring, and screw the plunger end shield back on (4,3 and 2).
- Carry out the same procedures in reverse to remount the unit.



When fitting the upper case, ensure the joint is perfectly positioned in its slot after reassembly.

Recalibrate the pressure sensor (see "Calibrations") then carry out the regular servicing tests (see "Regular servicing sheet").

N°6, Procedure: Plunger advance control potentiometer

Safety:

For safety reasons, the technician should not carry out any maintenance when the device is connected to the 230 V mains supply voltage.

Disconnect the mains power supply cable.

Equipment required:

- 1 Posidriv Z1 screwdriver.
- 1 flat screwdriver.
- 1 flat key (12).
- 1 potentiometer dismantling tool ref. T300869.

Maintenance level:

Level 2, specialised technician (see documentation on biomedical training).

Procedure:

Access

- Turn the Pilot over onto the upper case.
- Unscrew the 6 Phillips head screws (ref. 1) located at the bottom of the lower housing case, which link this to the upper case.
- Keep the Pilot assembled and turn it over onto the lower case.
- Remove the upper case making sure the CPU board flat jumper is not accidentally removed in the process.
- Disconnect the CPU board flat jumper.

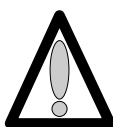

Hands must not come into contact with the CPU boards.

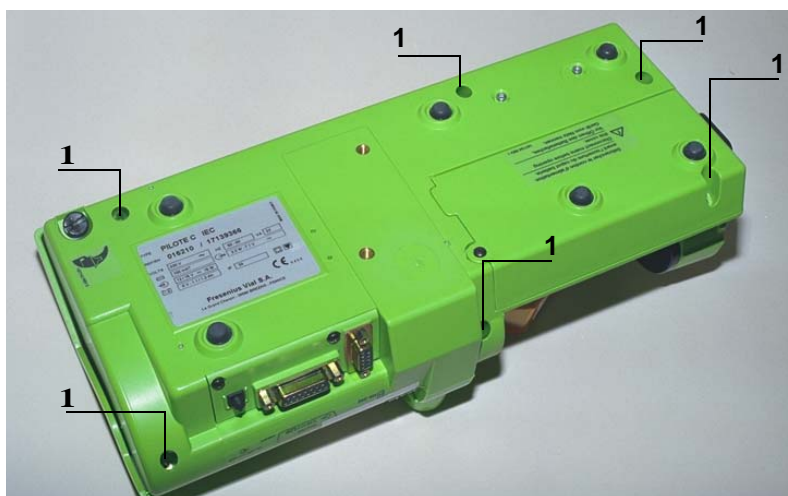

Dismounting

- Press the syringe pump disengagement lever towards the back of the Pilot as far as possible.
- Maintain this position and slide the whole unit to the back left.
- Remove the plunger guide.
- Disconnect the black connectors (ref. 2).
- Unscrew the flat jumper mounting lug (ref. 3) without removing it.
- Remove the mechanical plunger unit from its slot.
- Disconnect the blue connector from the flat jumper (ref. 4).
- Remove the mechanical plunger unit.
- Unscrew the potentiometer lock nut (ref. 5).
- Remove the tooth lockwasher and the potentiometer.

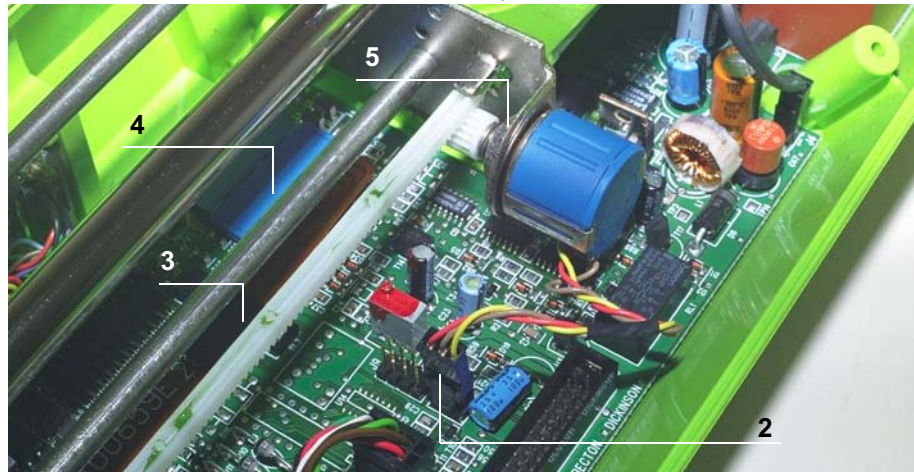

Reassembly

- Dismount the end shield from the reducer frame.
- Mount the potentiometer onto the end shield (screw the nut onto a thread).
- Position the end shield in equipment T 300 869 and lock it into position using the knurled screw.
- Position the potentiometer in the device and bring it up against the end shield.
- Tighten the potentiometer.
- Extract the end shield from device T 300 869.
- Mount the pinion on the potentiometer (match up the indexing plane).
 - The larger diameter of the pinion must be flattened against the potentiometer.
- With the potentiometer facing you, turn the pinion anticlockwise until it blocks, then turn it $\frac{1}{4}$ of a turn in the opposite direction.
- Mount the moving mechanical assembly onto the reducer frame.
- Slide the end shield onto the guides and rack.
 - Check the position of the input bearing which must be on the plunger side.
 - Ensure the flex circuit is not damaged when mounting (folding).
- Secure the end shield using the three M3x3 TC screws.
- Secure the input bearing using the two M3x3 TC screws.



When fitting the upper case, ensure the joint is perfectly positioned in its slot after reassembly.

Recalibrate the position sensor (see "Calibrations") then carry out the regular servicing tests (see "Regular servicing sheet").

N°7, Procedure: Plunger cover and/or disengagement lever + anti-siphon arm

Safety:

For safety reasons, the technician should not carry out any maintenance when the device is connected to the 230 V mains supply voltage.

Disconnect the mains power supply cable.

Equipment required:

- 1 Posidriv Z1 screwdriver.

Maintenance level:

Level 2, specialised technician (see documentation on biomedical training).

Procedure:

Access

- Press the syringe pump disengagement lever towards the back of the Pilot as far as possible.
- Maintain this position and slide the whole unit to the back right.

Dismounting

- Unscrew the 3 Phillips head screws (ref. 1) located at the bottom of the plunger end shield which links this to the plunger cover.
- Remove the plunger end shield (ref. 2), the disengagement lever and its spring (ref. 3) as well as the protective plunger film (ref. 4).
- Unscrew and remove the Phillips head screw and the washer (ref. 5) which attach the anti-siphon cam to the anti-siphon arm.
- Remove the cam/anti-siphon arm assembly (ref. 6).

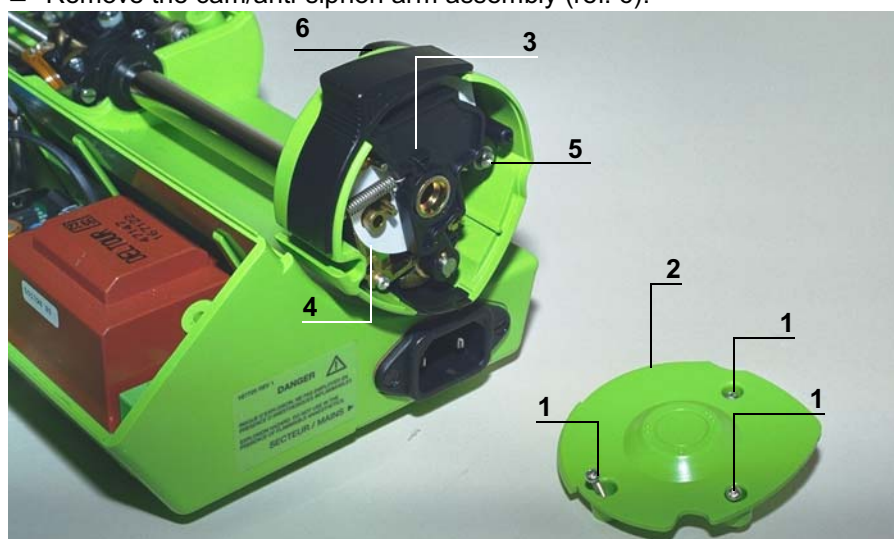

Reassembly

Carry out the same procedures in reverse to remount the unit.

- Impregnate the screw with weak loctite (ref. 5) before mounting the cam and arm assembly.



When fitting the upper case, ensure the joint is perfectly positioned in its slot after reassembly.

Perform the regular servicing tests (see "Regular servicing sheet").

N°8, Procedure: Power supply board

Safety:

For safety reasons, the technician should not carry out any maintenance when the device is connected to the 230 V mains supply voltage.

Disconnect the mains power supply cable.

Equipment required:

- 1 Posidriv Z1 screwdriver.
- 1 small flat screwdriver
- 1 antistatic wriststrap.

Maintenance level:

Level 2, specialised technician (see documentation on biomedical training).

Procedure:

Access

- Turn the **Pilot** over onto the upper case.
- Unscrew the 6 Phillips head screws (ref. 1) located at the bottom of the lower case, which link this to the upper case.
- Keep the **Pilot** assembled and turn it over onto the lower case.
- Remove the upper case making sure the CPU board flat jumper is not accidentally removed in the process.
- Disconnect the CPU board flat jumper.

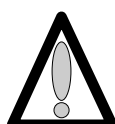

Hands must not come into contact with the CPU boards.

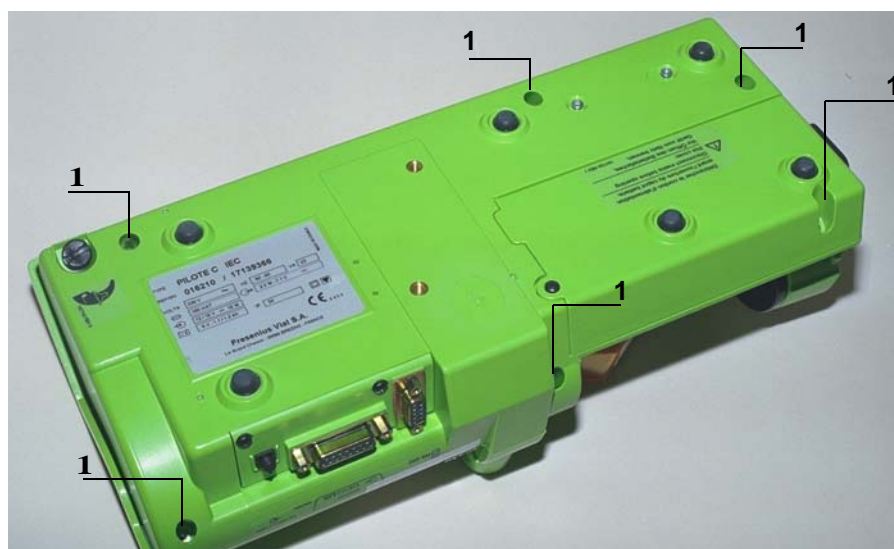

Dismounting

- Press the syringe pump disengagement lever towards the back of the Pilot as far as possible.
- Maintain this position and slide the whole unit to the back left.
- Remove the syringe pump guide.
- Disconnect the black connectors.



When electronic components are handled, it is recommended to wear an antistatic wriststrap linked to ground and to work on an antistatic foam mat.

- Unscrew the flat jumper mounting lug (ref 2) without removing it.
- Remove the mechanical plunger unit from its slot.
- Disconnect the blue connector from the flat jumper (ref. 3).
- Remove the mechanical plunger unit.
- Disconnect the black connectors (ref 4, ref 5, ref.6, ref.7, ref.8, ref.9).
- Unscrew the 3 Phillips head screws (ref. 10) located on the power supply board, which link this to the lower case.
- Unscrew the 2 Phillips head screws (ref. 11) located on lower case, which link this to the power supply board.
- Remove the power supply board.

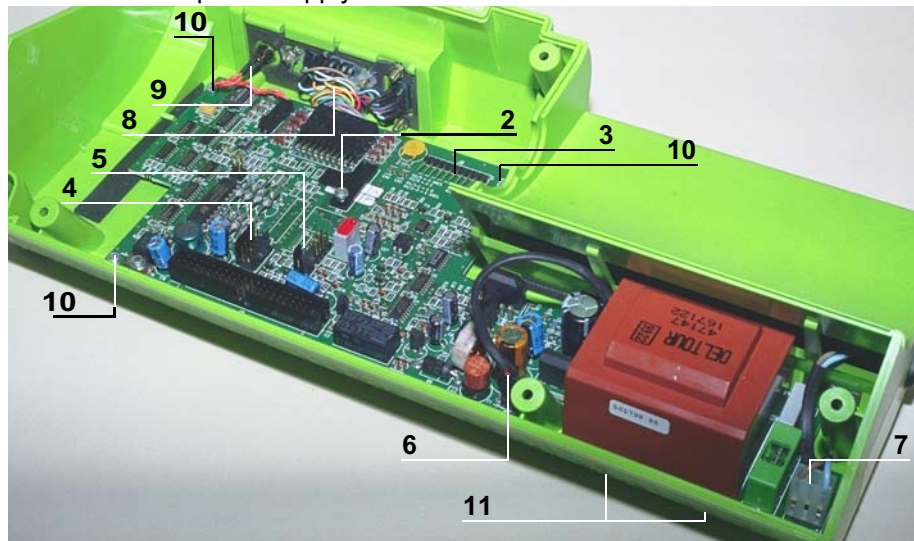

Reassembly

Carry out the same procedures in reverse to remount the unit.



When fitting the upper case, ensure the joint is perfectly positioned in its slot after reassembly.

Recalibrate the force sensor (see "Calibrations") then carry out the regular servicing tests (see "Regular servicing sheet").

N°9, Procedure: Battery holder and battery

Safety:

For safety reasons, the technician should not carry out any maintenance when the device is connected to the 230 V mains supply voltage.

Disconnect the mains power supply cable.

Equipment required:

- 1 Posidriv Z1 screwdriver.

Maintenance level:

Level 2, specialised technician (see documentation on biomedical training).

Procedure:

Access

- Turn the **Pilot** over onto the upper case.

Dismounting

- Unscrew the 2 Phillips head screws (ref. 1) to be found in the lower case battery holder kit, which link this to the lower case.
- Swivel the battery holder and remove the battery.
- Disconnect this.

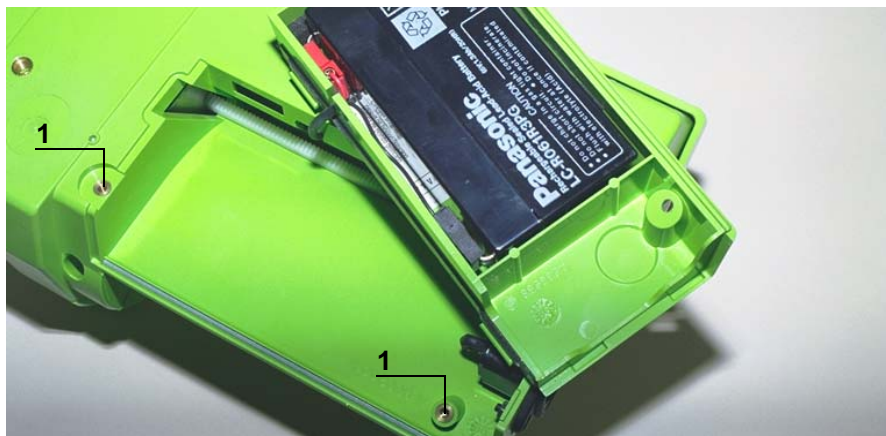

Reassembly

Carry out the same procedures in reverse to remount the unit.



It is recommended to perform a full loading and unloading cycle to ensure the battery is in working condition.

Perform the regular servicing tests (see "Regular servicing sheet").

N°10, Procedure: Rear plug support

Safety:

For safety reasons, the technician should not carry out any maintenance when the device is connected to the 230 V mains supply voltage.

Disconnect the mains power supply cable.

Equipment required:

- 1 Posidriv Z1 screwdriver.

Maintenance level:

Level 2, specialised technician (see documentation on biomedical training).

Procedure:

Access

- Turn the **Pilot** over onto the upper case.
- Unscrew the 6 Phillips head screws (ref. 1) located at the bottom of the lower case, which link this to the upper case.
- Keep the **Pilot** assembled and turn it over onto the lower case.
- Remove the upper case making sure the CPU board flat jumper is not accidentally removed in the process.
- Disconnect the CPU board flat jumper.

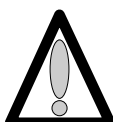

Hands must not come into contact with the CPU boards.

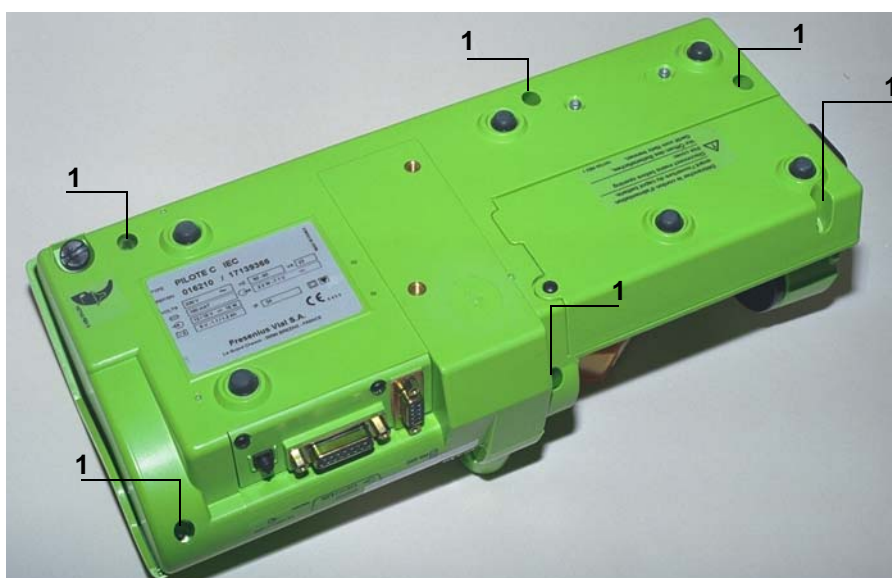

Dismounting

- Disconnect the two black connectors (ref 2 and ref 3).
- Unscrew the 2 Phillips head screws (ref. 4) located on the cabled plug support, which link this to the lower case.
- Remove the cabled plug support.

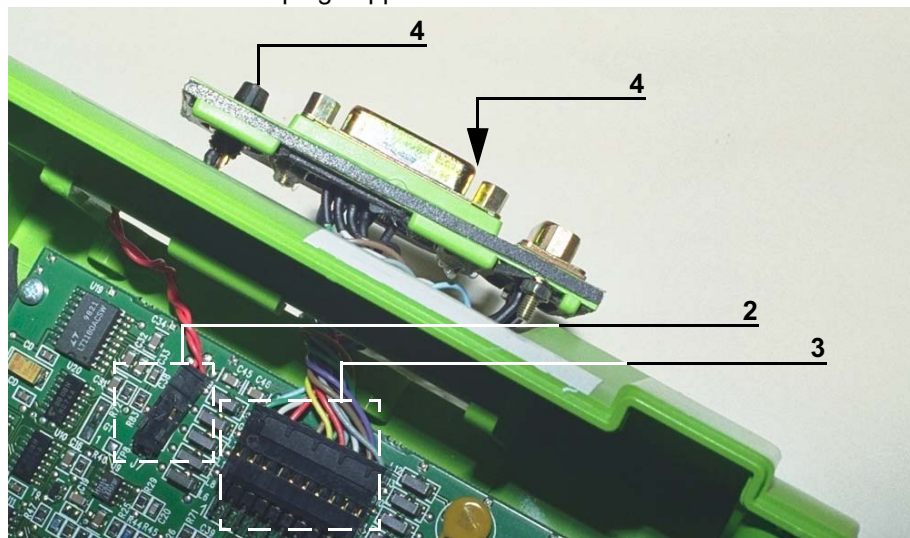

Reassembly

Carry out the same procedures in reverse to reassemble the parts.

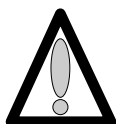

If the number of rear door connector points is different to the number of power supply board points, make the connections as described below.

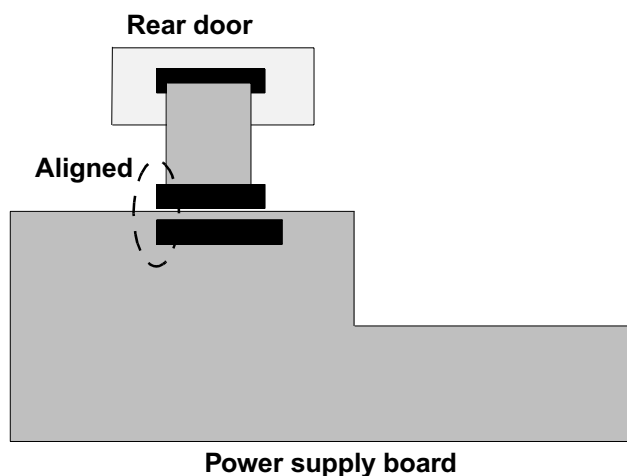

Perform the regular servicing tests (see "Regular servicing sheet").

N°11, Procedure: Ribbon cable winding kit

Safety:

For safety reasons, the technician should not carry out any maintenance when the device is connected to the 230 V mains supply voltage.

Disconnect the mains power supply cable.

Equipment required:

- 1 Posidriv Z1 screwdriver.

Maintenance level:

Level 2, specialised technician (see documentation on biomedical training).

Procedure:

Access

- Turn the **Pilot** over onto the upper case.
- Unscrew the 6 Phillips head screws (ref. 1) located at the bottom of the lower case, which link this to the upper case.
- Keep the **Pilot** assembled and turn it over onto the lower case.
- Remove the upper case making sure the CPU board flat jumper is not accidentally removed in the process.

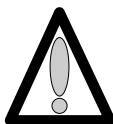

Hands must not come into contact with the CPU boards.

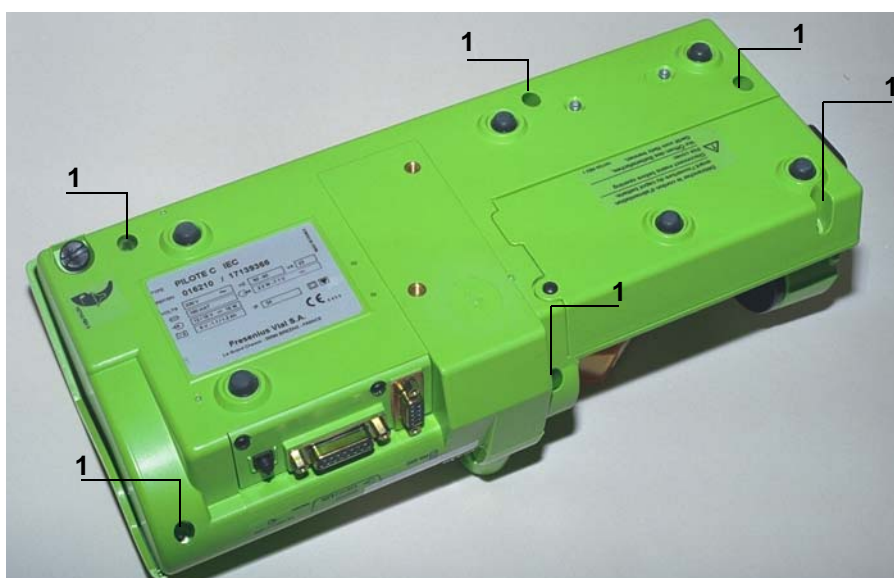

Dismounting

- Press the syringe pump disengagement lever towards the back of the Pilot as far as possible.
- Maintain this position and slide the whole unit to the back left.
- Remove the plunger guide.
- Disconnect the black connectors (ref. 2 and ref. 3).



When electronic components are handled, it is recommended to wear an antistatic wriststrap linked to ground and to work on an antistatic foam mat.

- Unscrew the flat jumper tongue (ref. 4) without removing it.
- Remove the mechanical plunger unit from its slot.
- Disconnect the blue connector (ref. 5) from the flat jumper.
- Remove the mechanical plunger unit.
- Fully unscrew and remove the guiding tongue (ref. 4).

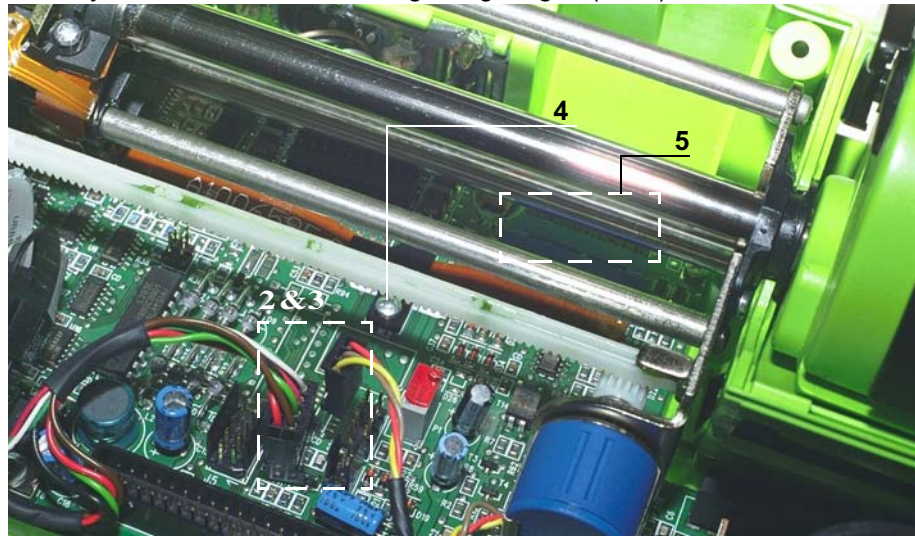

Remounting

Fitting the flexible tongue:

- Remove the clip (ref. 6).
- Stick the flexible tongue (ref. 7) with the adhesive facing the ribbon cable.
- Reposition the clip making sure the ribbon cable and the flexible tongue are centred on the mechanical unit sprocket.
- Lift both ends of the flexible tongue slightly.

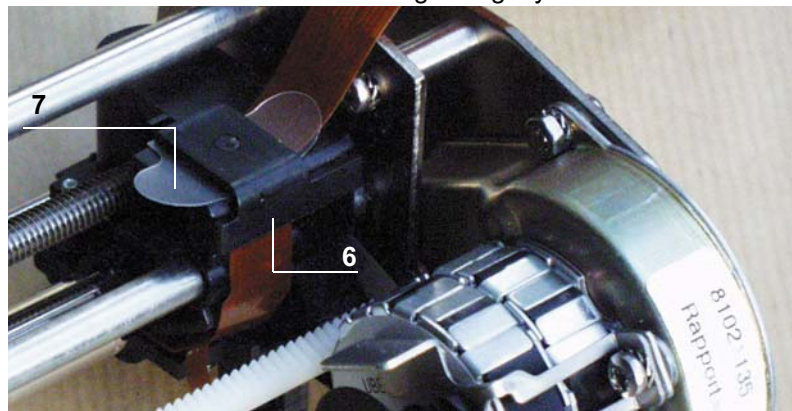

Fitting the guiding flange:



There are several types of flange tongues. If you have an older version, replace it with that provided with the kit.

- Position the new guiding flange (ref. 4) using the two screws.

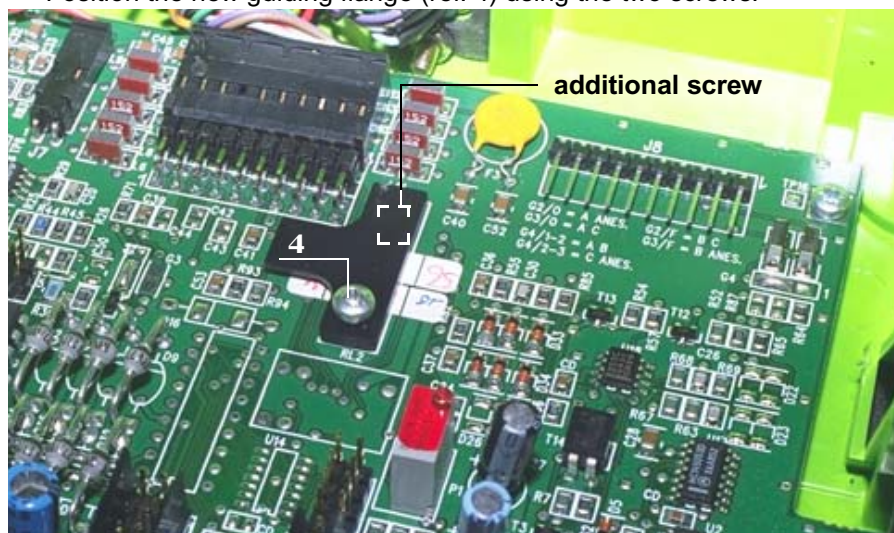

- Disconnect the blue connector (ref. 5) from the flat jumper.
- Position the whole mechanical plunger unit making sure the ribbon cable is centred under the flange.
- Perform a few round cycles to check the ribbon cable winds up correctly.
- Connect the black connectors (ref. 2 and ref. 3).
- Replace the plunger guide.

Carry out the same procedures in reverse to remount the upper case.



When fitting the upper case, ensure the joint is perfectly positioned in its slot after reassembly.

Perform the regular servicing tests (see "Regular servicing sheet").

N°12, Procedure: Syringe head detection plunger kit

Safety:

For safety reasons, the technician should not carry out any maintenance when the device is connected to the 230 V mains supply voltage.

Disconnect the mains power supply cable.

Equipment required:

- 1 Posidriv Z1 screwdriver.
- 1 2.5 hexagon socket key (2.5).

Maintenance level:

Level 2, specialised technician (see documentation on biomedical training).

Procedure:

Access

- Turn the **Pilot** over onto the upper case.
- Unscrew the 6 Phillips head screws (ref. 1) located at the bottom of the lower case, which link this to the upper case.
- Keep the **Pilot** assembled and turn it over onto the lower case.
- Remove the upper case making sure the CPU board flat jumper is not accidentally removed in the process.

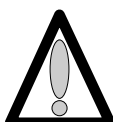

Hands must not come into contact with the CPU boards.

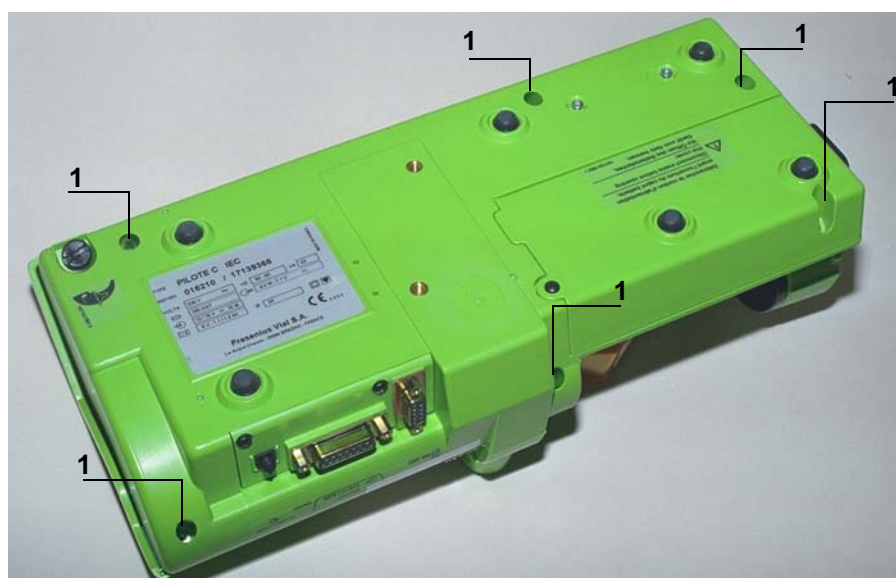

- Press the syringe pump disengagement lever towards the back of the Pilot as far as possible.
- Maintain this position and slide the whole unit to the back right.
- Remove the syringe pump guide.

Dismounting

- Unscrew the 3 Phillips head screws (ref. 2) located at the bottom of the plunger end shield slots which link this to the plunger cover.

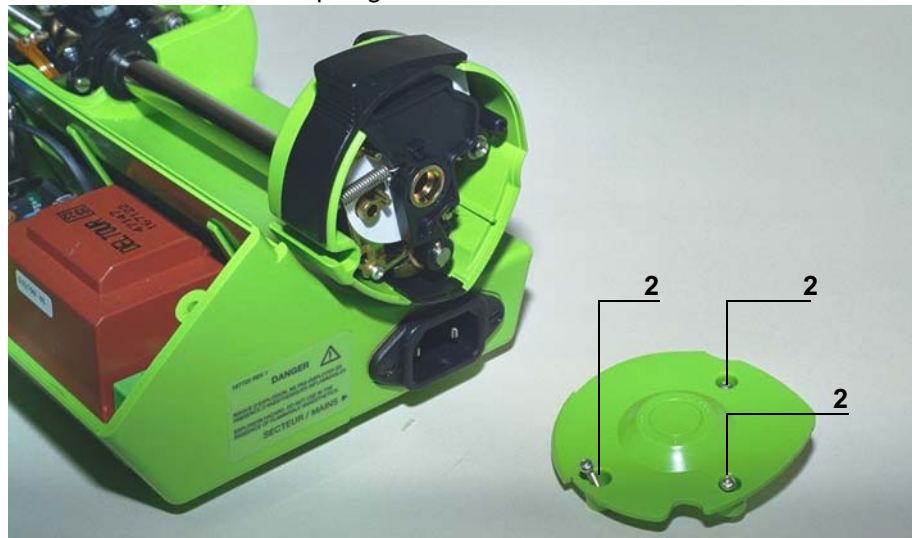

- Remove the plunger end shield, the disengagement lever and its spring as well as the protective plunger film.
- Remove the plunger cover clip.
- Unscrew the 2 Phillips head screws (ref. 3 and 4) which link the plunger support to the plunger cover.
- Unscrew and remove the Phillips head screw and the washer (ref. 5) which hold the anti-siphon cam to the anti-siphon arm.
- Remove the cam/arm unit as well as the plunger cover.
- Remove the bonding pad label (ref. 6).
- Unscrew the six hexagon socket screws (ref. 7) and remove the plunger unit.

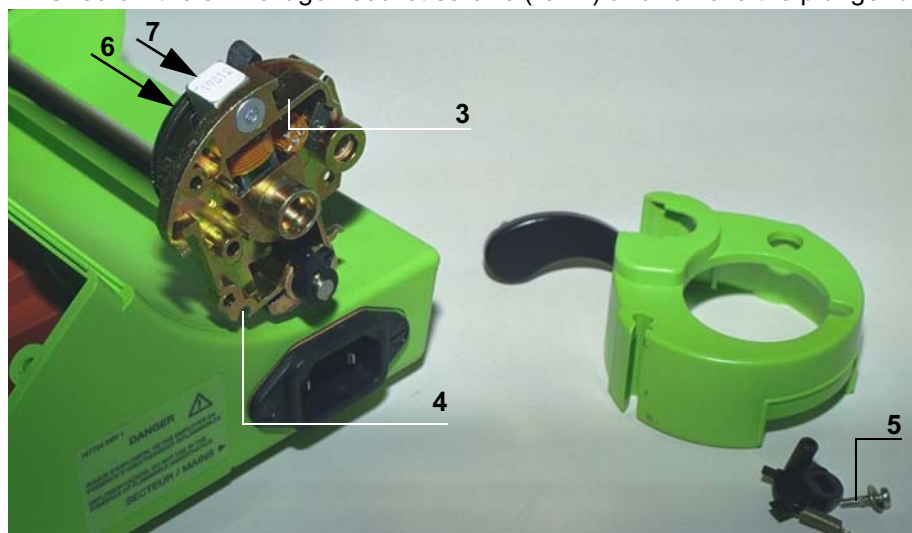

Remounting

- If necessary, cut the protective flexible ribbon cable label if it protrudes over the edge of the sensor.
- Impregnate with weak loctite and screw the 6 hexagon socket screw (ref. 6) which holds the new bonding pad to the force sensor.
- Break the contact of the bonding pad fixing lugs from the plunger cover.
- Mount the plunger cover onto the plunger support.



Weak loctite must be used to mount the new arm and the new anti-siphon arm supplied with the kit.

- Centre the bonding pad in relation to the plunger cover and lock the bonding pad/sensor unit into position on the plunger support.
- Check the free movement of the removable stop plate.

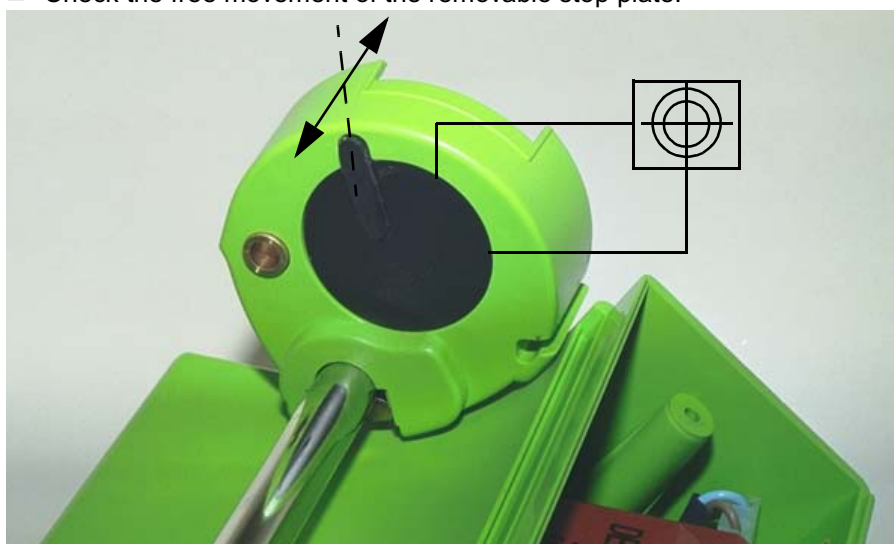

Do not forget to replace the anti-siphon cam with the new one supplied with the kit.

- Position and screw the cam/anti-siphon arm unit using the Phillips head screw and the washer (ref. 5).
 - Screw the 2 Phillips head screws (ref. 3 and 4) which link the plunger support to the plunger cover.
 - Position the plunger cover clip.
 - Cover the plunger with the protective film, and mount the disengagement lever and its spring, and screw the plunger end shield back on.
- Carry out the same procedures in reverse to reassemble the unit.



When fitting the upper case, ensure the joint is perfectly positioned in its slot after reassembly.

Perform the regular servicing tests (see "Regular servicing sheet").

N°12, Procedure: Centering ring kit

Safety:

For safety reasons, the technician should not carry out any maintenance when the device is connected to the 230 V mains supply voltage.

Disconnect the mains power supply cable.

Equipment required:

- 1 Posidriv Z1 screwdriver.
- 1 cutter.
- GEB type 100% silicone grease.

Maintenance level:

Level 2, specialised technician (see documentation on biomedical training).

Procedure:

Access

- Turn the **Pilot** over onto the upper case.
- Unscrew the 6 Phillips head screws (ref. 1) located at the bottom of the lower case, which link this to the upper case.
- Keep the **Pilot** assembled and turn it over onto the lower case.
- Remove the upper case making sure the CPU board flat jumper is not accidentally removed in the process.

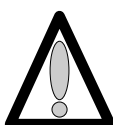

Hands must not come into contact with the CPU boards.

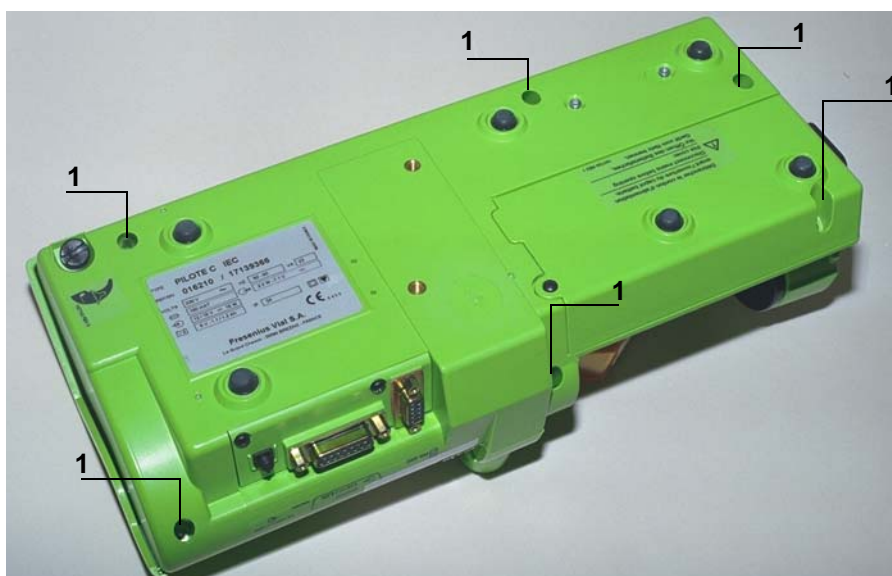

- Press the syringe pump disengagement lever towards the back of the Pilot as far as possible.
- Maintain this position and slide the whole unit to the back left.
- Remove the plunger guide.
- Disconnect the black connectors (ref. 2).
- Unscrew the flat jumper mounting lug (ref. 3) without removing it.
- Remove the mechanical plunger unit from its slot.
- Disconnect the blue connector from the flat jumper (ref. 4).
- Remove the mechanical plunger unit.

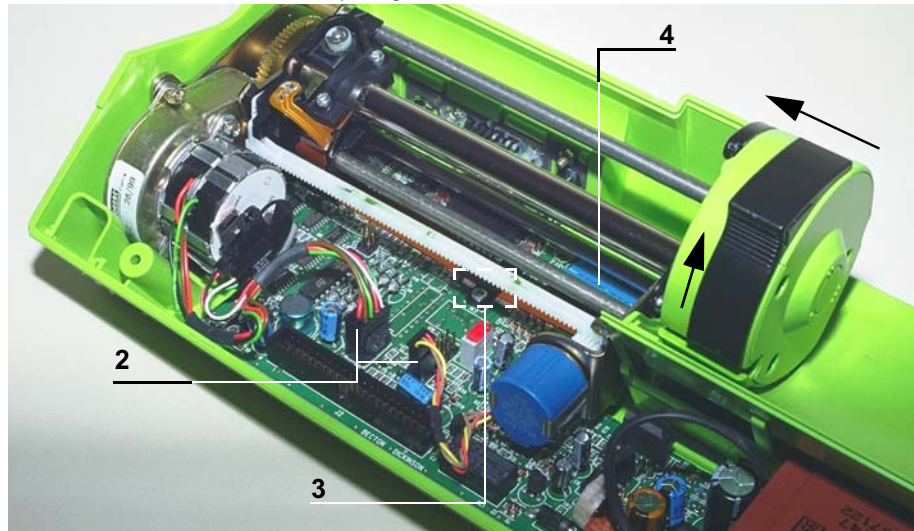

- Press the syringe pump disengagement lever towards the back of the Pilot as far as possible.
- Maintain this position and slide the whole unit to the back right.

Dismounting

- Unscrew the 2 slotted head screws (ref. 5) which link the centering ring to the mechanical end shield.
- Using the cutter, cut the input bearing and remove it from the plunger tube.

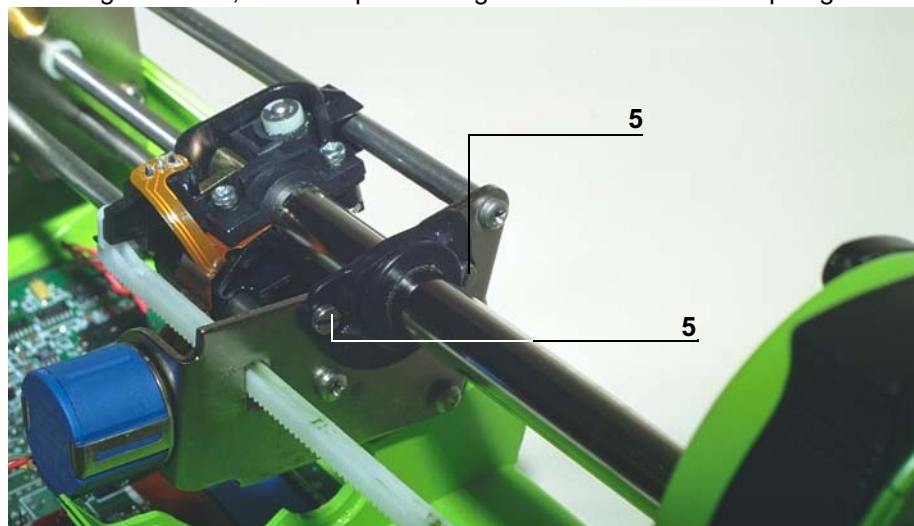

Remounting

- Mount the new slotted input bearing onto the plunger tube by twisting it.
- Laying it flat on a table, cut the O-ring using a cutter.
- Place the O-ring around the tube.
- Fit the O-ring into the centering ring slot (horizontal cut, so as to avoid lining it up with the centering ring cut).
- Mount the stainless steel slotted plate onto the pin, by twisting it.
- Place the silicone grease cord onto the plate around the passage of the pin.
- Place the plate on the input bearing.
- Position the whole assembly against the mechanical end shield and screw it on using the two slotted screws (ref. 5).
- Check the plunger slides correctly.



It should slide uniformly across the entire centering ring and slight friction is due to the O-ring scraping against the tube.

Perform the regular servicing tests (see "Regular servicing sheet").

N°14, Procedure: Flex circuit and tube kit

Safety:

For safety reasons, the technician should not carry out any maintenance when the device is connected to the 230 V mains supply voltage.

Disconnect the mains power supply cable.

Equipment required:

- 1 Posidriv Z1 screwdriver.
- 1 antistatic wriststrap.

Maintenance level:

Level 2, specialised technician (see documentation on biomedical training).

Procedure:

Access

- Turn the Pilot over onto the upper case.
- Unscrew the 6 Phillips head screws (ref. 1) located at the bottom of the lower case, which link this to the upper case.
- Keep the Pilot assembled and turn it over onto the lower case.
- Remove the upper case making sure the CPU board flat jumper is not accidentally removed in the process.
- Disconnect the CPU board flat jumper.

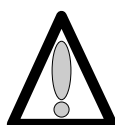

Hands must not come into contact with the CPU boards.

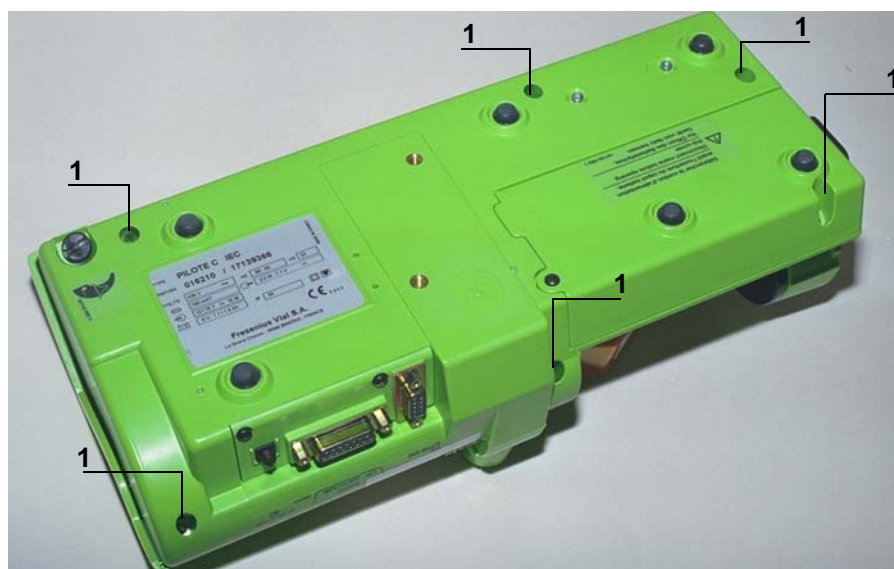

Dismounting

- Press the syringe pump disengagement lever towards the back of the Pilot as far as possible.
- Maintain this position and slide the whole unit to the back left.
- Remove the plunger guide.
- Disconnect the black connectors (ref. 2).
- Unscrew the flat jumper mounting lug (ref. 3) without removing it.
- Remove the mechanical plunger unit from its slot.
- Disconnect the blue connector from the flat jumper (ref. 4).
- Remove the mechanical plunger unit.

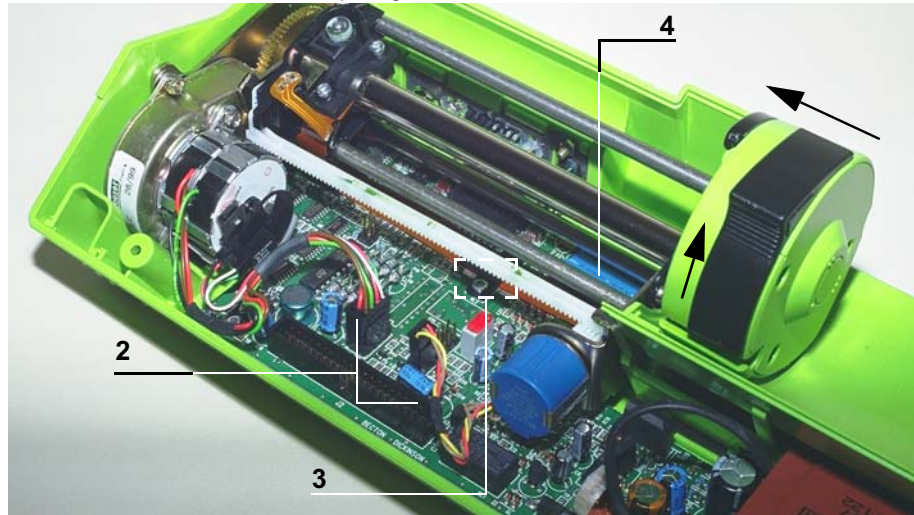

- Press the syringe pump disengagement lever towards the back of the Pilot as far as possible.
- Maintain this position and slide the whole unit to the back right.



Welding and unwelding operations are carried out using a soldering iron fitted with a tip in good condition, constantly tapered and clean kept.. The temperature of the iron should be between 315°C and 340°C.

- Unweld the flex circuit (ref. 5) ensuring the disengagement switch is not damaged in the process.
- Unscrew the 2 slotted head screws (ref. 6) which link the centering ring to the mechanical end shield.
- Unscrew the 2 Phillips head screws (ref. 7) which link the centering ring to the mechanical end shield.
- Remove the flex circuit clip (ref. 8).

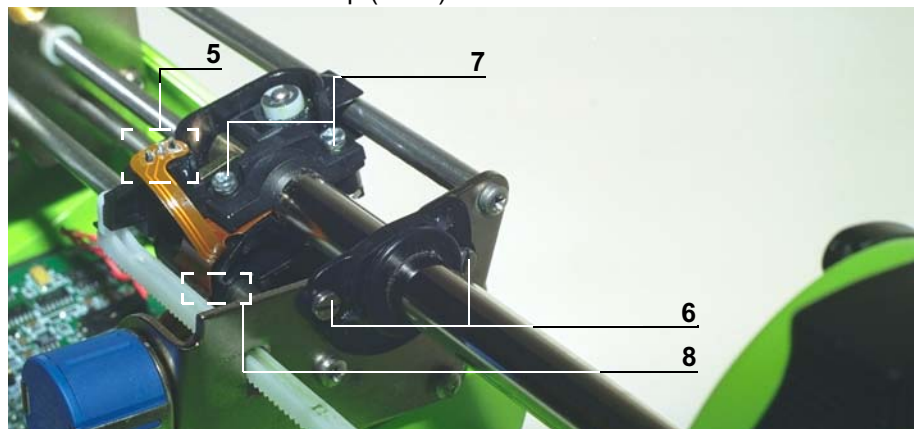

- Unscrew the 3 Phillips head screws (ref. 9) located at the bottom of the plunger end shield which link this to the plunger cover.

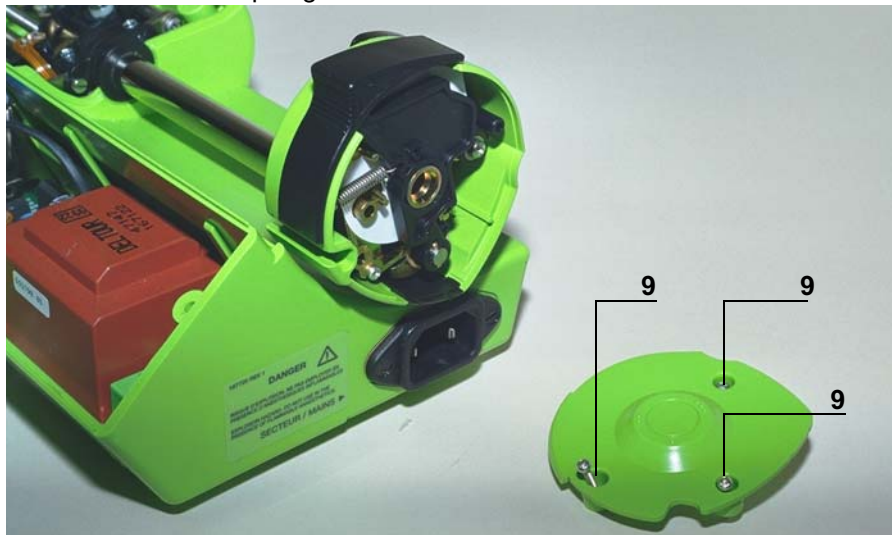

- Remove the plunger end shield, the disengagement lever and its spring (ref. 10) as well as the protective plunger film (ref. 11).

- Remove the plunger cover clip (ref.12).

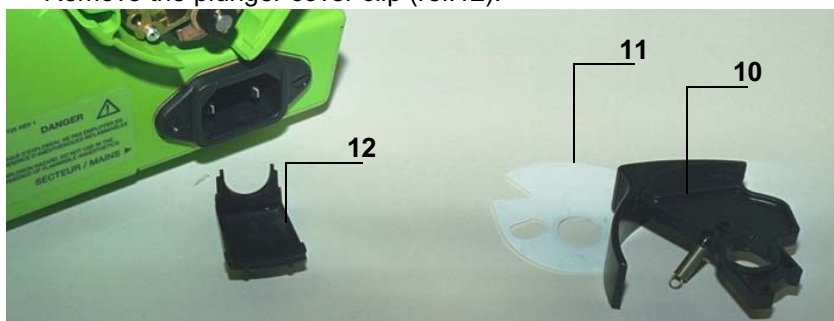

- Unscrew the 2 Phillips head screws (ref. 13 and 14) which link the plunger support to the plunger cover.

- Unscrew and remove the Phillips head screw and the washer (ref. 15) which attach the anti-siphon cam to the anti-siphon arm.

- Remove the cam/arm unit as well as the plunger cover.

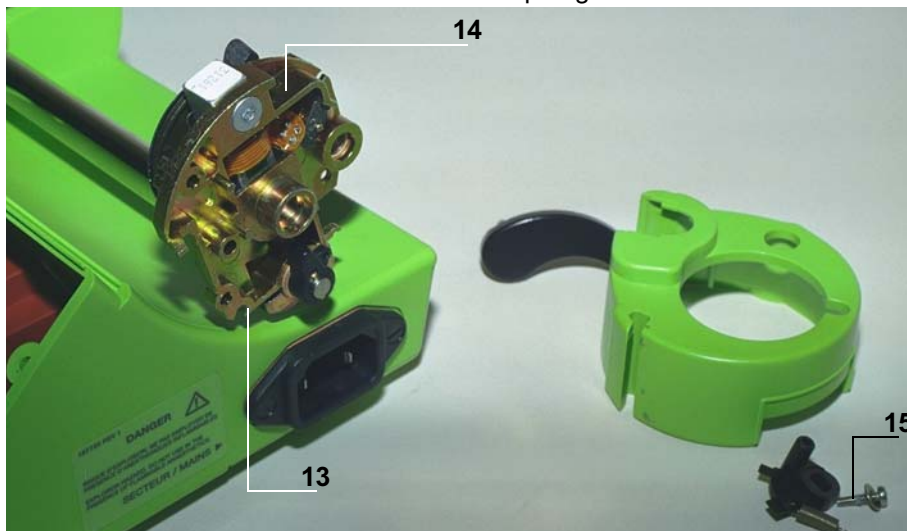

- Unscrew the 6 hexagon socket screws (ref. 16) and remove the force sensor.
- Unscrew the 2 Phillips head screws (ref. 17) which attach the clamping collar to the plunger support.
- Remove the disengagement pin (ref. 18).

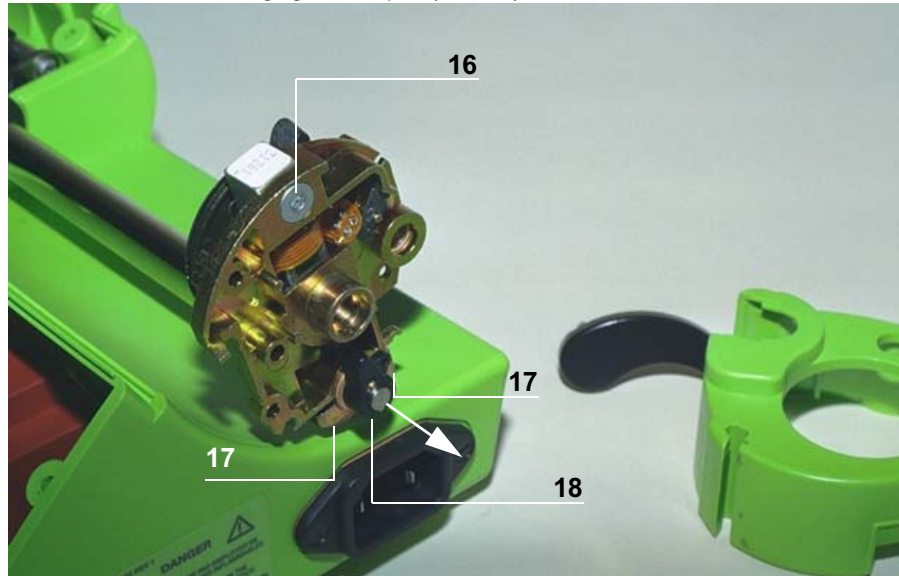

Welding and unwelding operations are carried out using a soldering iron fitted with a tip in good condition, constantly tapered and clean kept.. The temperature of the iron should be between 315°C and 340°C.

- Unweld the sensor wires:



When dismantling the force sensor, ensure the welding blocks are not damaged and the square is not removed in the process.

- Add more weld to facilitate the unwelding process.
- Heat and pull on the wires one by one.

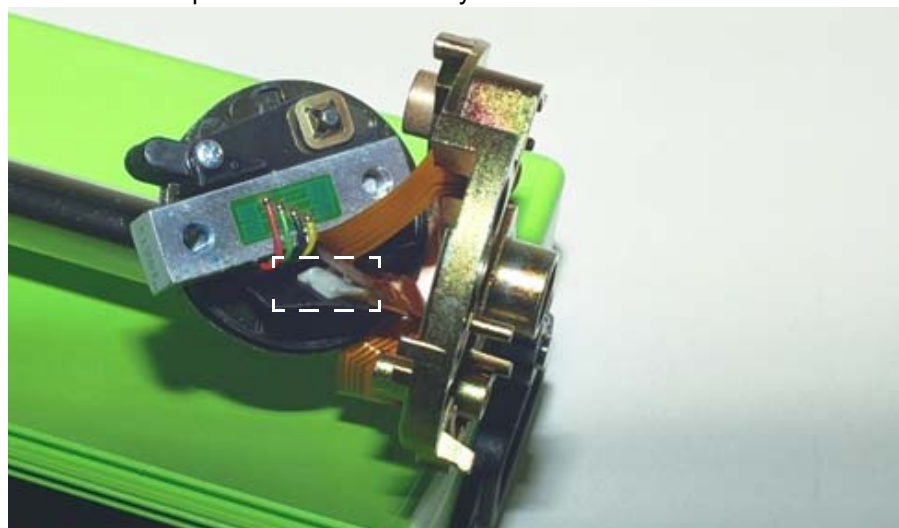

Remounting

- Remove the sticky tape holding the flex circuit to the tube.
- Cut the part of the flex circuit which corresponds to version A2.
- Weld the disengagement microswitch to the ribbon cable at approximately 1.5 mm without flattening it against this.
- Weld the force sensor wires. Weld the wires to the new sensor, respecting the colour code.
 - Taper the 4 welding wires.
 - Weld the 4 wires.
 - Check that the welding has been carried out correctly. It should not form a ball, but should lie against the length of the wire.

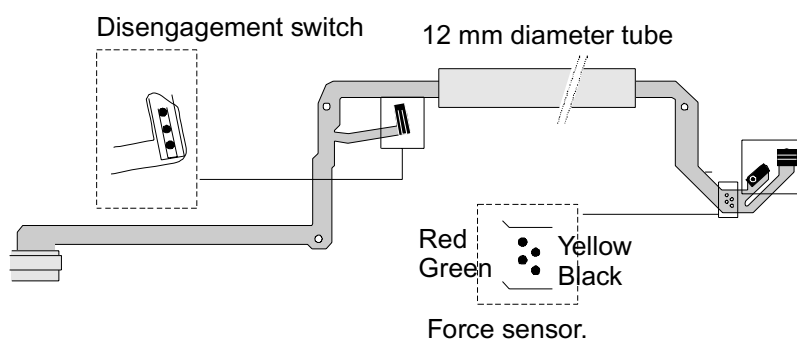

- Slide the excess wire into the force sensor oblong making sure the flex circuit is well-positioned.
- Impregnate with weak loctite and screw the 6 hexagon socket screws (ref. 10) which attach the sensor to the plunger support.

Carry out the same procedures in reverse to remount the unit.



Do not forget to impregnate the cam/arm clamping screw (rep. 15) with weak loctite.



When fitting the upper case, ensure the joint is perfectly positioned in its slot after reassembly.

Recalibrate the force sensor (see "Calibrations") then carry out the regular servicing tests (see "Regular servicing sheet").

N°14, Procedure: Upper and lower cases

Safety:

For safety reasons, the technician should not carry out any maintenance when the device is connected to the 230 V mains supply voltage.

Disconnect the mains power supply cable.

Equipment required:

- 1 Posidriv Z1 screwdriver.
- 1 antistatic wriststrap.
- 1 soldering iron.
- "RADIEL Sn60Pb RI 1" welding wire (cleaning not required for rewelding) or equivalent.

Maintenance level:

Level 2, specialised technician (see documentation on biomedical training).

Procedure:

Access

- Turn the **Pilot** over onto the upper case.
- Unscrew the 6 Phillips head screws (ref. 1) located at the bottom of the lower case, which link this to the upper case.
- Keep the **Pilot** assembled and turn it over onto the lower case.
- Remove the upper case making sure the CPU board flat jumper is not accidentally removed in the process.
- Disconnect the CPU board flat jumper.

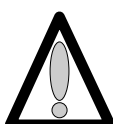

Hands must not come into contact with the CPU boards.

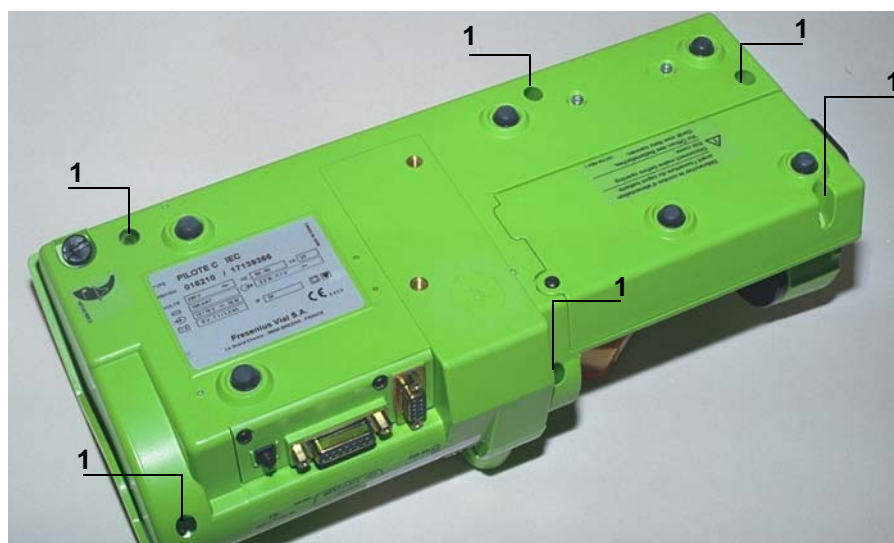

Dismounting the upper cover

- Dismount the central unit and display boards (see corresponding sheet).
- Dismount the syringe clamp (see corresponding sheet).
- Dismount the syringe detection system (see corresponding sheet).

Remounting the upper cover

- Remount the syringe detection system (see corresponding sheet).
- Remount the syringe clamp (see corresponding sheet).
- Remount the central unit and display boards (see corresponding sheet).
 - If the original lower case is fitted with a removable buzzer bell, you can use your "CPU and display board" kit without having to adapt it.
 - If the original lower case has a cylindrical guide for accommodating the buzzer, the buzzer from the "CPU and display board" kit must be replaced with the buzzer supplied with the spare parts as the latter is fitted with snubbers and a separate foam joint. Follow the mounting diagram shown below to carry out this adaptation procedure.



Welding and unwelding operations are carried out using a soldering iron fitted with a tip in good condition, constantly tapered and kept clean. The temperature of the iron should be between 315°C and 340°C.

- Unweld the snubbers from the buzzer:
 - ◆ add more weld to facilitate the unwelding process.
 - ◆ Heat and pull on the buzzer pins one by one.



Clean the buzzer slot surfaces using a cloth soaked in rubbing alcohol.

- Weld the snubbers of the new buzzer:



Buzzer with snubbers



Display board

- ◆ taper the 2 buzzer pins to be welded.
- ◆ place the buzzer onto the board following the mounting diagram.
- ◆ weld to buzzer onto the board.
- ◆ check that the welding has been carried out correctly. It should not form a ball, but should lie against the length of the wire.

Continue with the remounting procedure, referring to the "central unit and display board" sheet.

Perform the regular servicing tests (see "Regular servicing sheet").

Dismounting the lower cover

- Dismount the power supply board (see corresponding sheet).
- Dismount the battery holder (see corresponding sheet).
- Dismount the rear plug support (see corresponding sheet).

Remounting the lower cover

Carry out the remounting procedure in reverse.

Perform the regular servicing tests (see "Regular servicing sheet").

7 Calibration



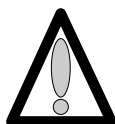

7.1 Calibration procedure



The calibration menu is reserved for authorised personnel only, its access is protected by a secret code.

7.1.1 Calibration access

Keyboard description

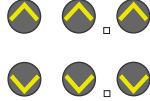
Key	Function
 ON OFF	ON , to switch the machine ON. OFF , to switch the machine off when pressed for over three seconds.
	SILENCE ALARM , to access the calibration mode.
	CONFIRM , to validate a choice.
	BOLUS , to access the calibration mode.
	The select keys allow to scroll the figures and letters on the LCD screen, on the units, tens, tenths segments etc.

Activate calibration

- Press the "SILENCE ALARM" and "BOLUS" keys simultaneously.
- Maintain this position while pressing "ON".
- When *E t R .* is displayed, release the "SILENCE ALARM" and "PRIME/BOLUS" keys, then validate within three seconds by pressing the "CONFIRM" key.
- *000.0*: enter the calibration mode access code using the + and - select keys, and validate.
- The device initiates the *E t R .4* calibration by default
- Scroll the different display unit calibration states using the "+" or "-" select keys.
 - *E t R .4*: calibration of the 3 battery voltage levels.
 - *E t R .6*: calibration of the position sensor.
 - *E t R .9*: calibration of the force sensor.

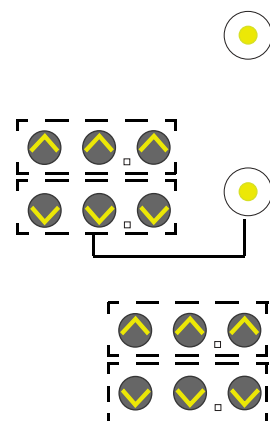
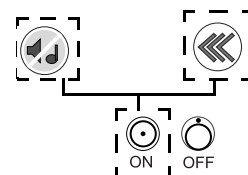

7.1.2 *E t A . 4* Calibration of the 3 battery voltage levels.

This menu enables the user to store the three Bat1, Bat2 and Bat3 battery voltage values in an EEPROM.

- *E t A . 4*, press "CONFIRM".
 - *b a t . 1*: supply the device with $6.3 \text{ V} \pm 0.05$ using a stabilised power supply.
 - ◆ Press "CONFIRM".
The voltage is read and stored in the EEPROM.
 - Press "CONFIRM".
 - *b a t . 2*: supply the device with $5.9 \text{ V} \pm 0.05$ using a stabilised power supply.
 - ◆ Press "CONFIRM".
The voltage is read and stored in the EEPROM.
 - Press "CONFIRM".
 - *b a t . 3*: supply the device with $5.7 \text{ V} \pm 0.05$ using a stabilised power supply.
 - ◆ Press "CONFIRM".
The voltage is read and stored in the EEPROM.
- By validating once again, it is possible to select another calibration.



7.1.3 *E t A . 5* Calibration of the position sensor.

This menu enables users to store both high and low displacement limit values in the EEPROM.

- *E t A . 5*, press "CONFIRM".
 - *H i g h*: Place a spacer measuring $115 \text{ mm} \pm 0.05$ ref. T 300940, into the fin groove.
 - ◆ Position the plunger in contact with the spacer.
 - ◆ Keep the plunger disengaged and press "CONFIRM".
The position value is read and stored in the EEPROM.
 - Press "CONFIRM".
 - *L o w*: Place a spacer measuring $20 \text{ mm} \pm 0.05$ ref. T 300775, into the fin groove.
 - ◆ Position the plunger in contact with the spacer.
 - ◆ Keep the plunger disengaged and press "CONFIRM".
The position value is read and stored in the EEPROM.



Once both high and low values have been stored in the EEPROM, the device indicates the number of LSB in decimals between the two measurement points. This value should be 776 ± 10 LSB.

- If the value is out of limits, carry out the calibration procedure once again.
- By validating once again, it is possible to select another calibration.

7.1.4 *E t A . 9* Calibration of the force sensor.

This menu enables users to store both high and low limit values in the EEPROM.

- *E t A . 9*, press "CONFIRM".
- *0 9*: set the potentiometer P1 of the power supply board so that the amplitude is $0.6 \text{ V} \pm 0.05 \text{ V}$ between J9.4 and the ground J9.1 without applying stress to the plunger.
 - ◆ press "CONFIRM". The position value is stored in the EEPROM.
- Press "CONFIRM".
- *5 t 9*: Apply a force of $5 \text{ Kg} \pm 50 \text{ g}$ to the plunger.
 - ◆ press "CONFIRM". The position value is stored in the EEPROM.
- By validating once again, it is possible to select another calibration.



8 Spare parts catalogue

8.1 Upper case

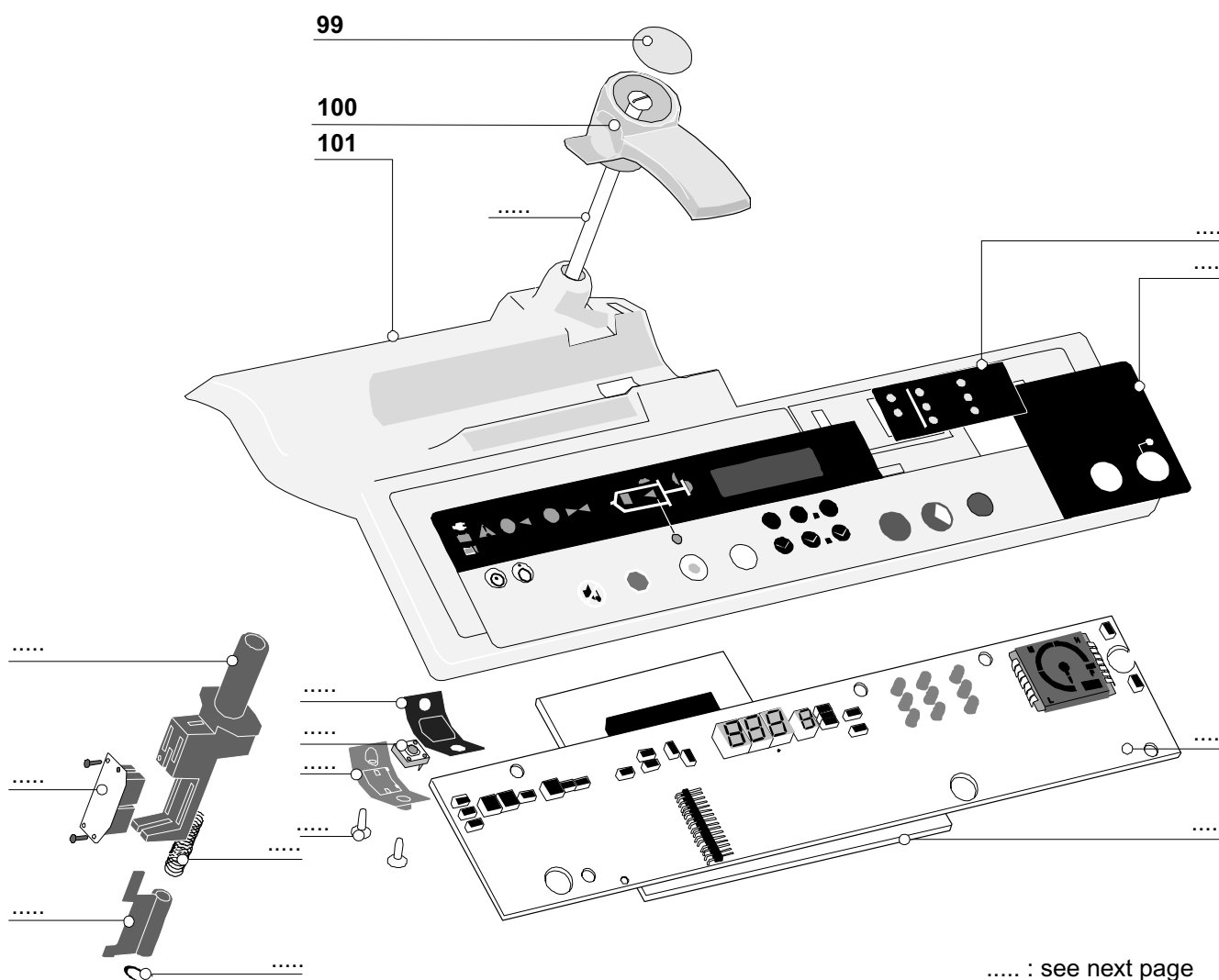

Mark	Qty	Reference	Name
	1	167246	LCD transparent pilot window
	1	167627	6 diam injected bumper
	2	199560	Female M3x12 hybrid spacer
	1	167067	PCB 500 protective film
	1	167296	Adhesive flat jumper protective film
	1	167632	Buzzer foam
	1	167636	Buzzer foam bell
99	1	167744	17.5 diam Pilot label
100	1	167476	20/60cc syringe clamp
101	1	199240	Upper case + label C IEC
	1	199241	Upper case + label C DIN
	1	199242	Upper case + label C NC

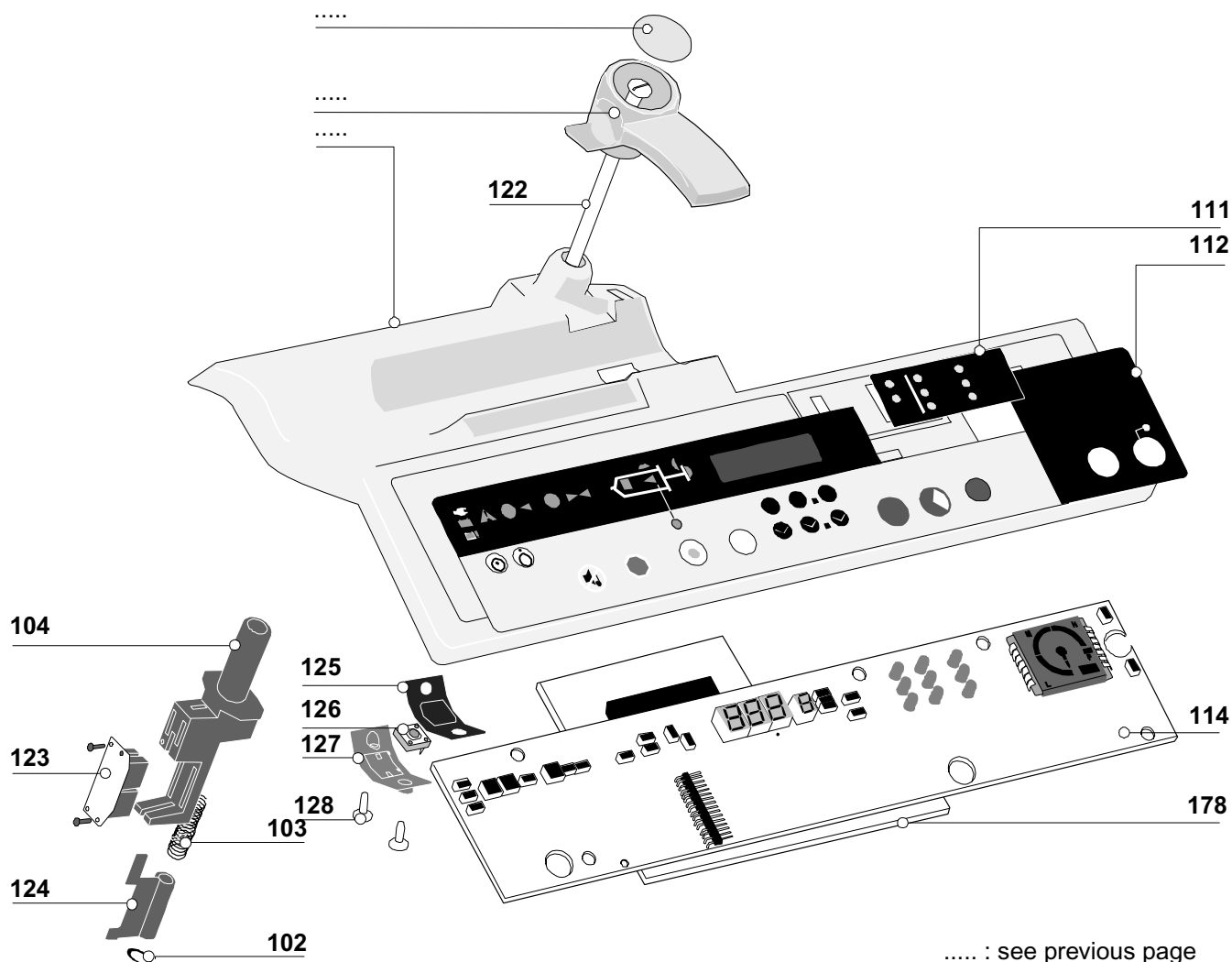

..... : see previous page

Mark	Qty	Reference	Name
102	1	167361	5 diam retaining ring
103	1	167310	Syringe clamp compression spring
104	1	167452	Injected PCB support (opto)
111	1	167670	Syringe list label
112	1	167642	C FR/CE pilot front panel
	1	167650	C DIN pilot front panel
	1	168108	C IS, SP, S, B, P pilot front panel
	1	167660	C NL pilot front panel
	1	167654	C IT pilot front panel
114	1	167552	Display board
	1	167715	Keyboard (active part)
122	1	167458	Syringe clamp shaft
123	1	167944	Wired CE HE 13 pilot opto PCB + 167372
124	1	167462	Pilot 20/60 ml obturator (not compatible with former version)

Mark	Qty	Reference	Name
125	1		Fin Pilot Switch Seal
126	1		ALPS SKHCAF switch
127	1		Fin Pilot Switch Support
128	2	199618	Eco-Syn TCB 2.2 x 8 screw
178	1	167568	CPU board

*Mounted on the 101 kit ref. 199240
or the sub-assembly ref. 167944
+ 167372*

8.2 Lower case

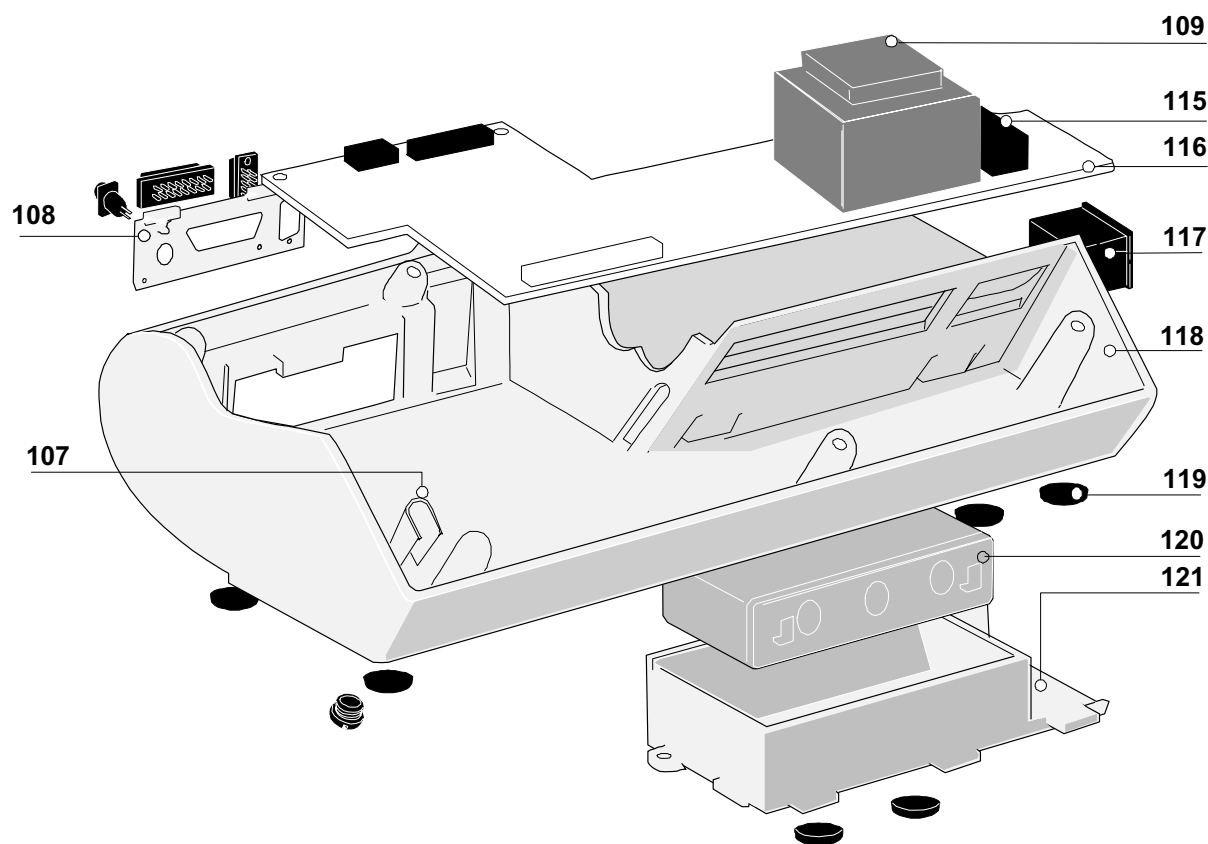

Mark	Qty	Reference	Name
	1	167059	Pilot guide rail
	1	167299	Buzzer adjustment washer
	1	167297	Spring washer
	1	167961	HE13 battery connector
	1	167122	Injected flexible PCB flange
	1	167355	Mains fibre gasket
	1	170416	Mains cord
107	1	167093	Buzzer bell
108	1	167969	C HE 13 pilot wired plug support
109	1	177201	Transformer
	1	167432	Buzzer adjustment button
115	1	170228	Fuse F2
116	1	167536	C 16 VA HE 13 pilot power supply board
117	1	167942	Wired mains socket
118	1	199200	Lower case + label C IEC
	1	199201	Lower case + label C DIN
	1	199202	Lower case + label C NL
	1	199203	Lower case + label C IS
119	6	167249	Black stop piece

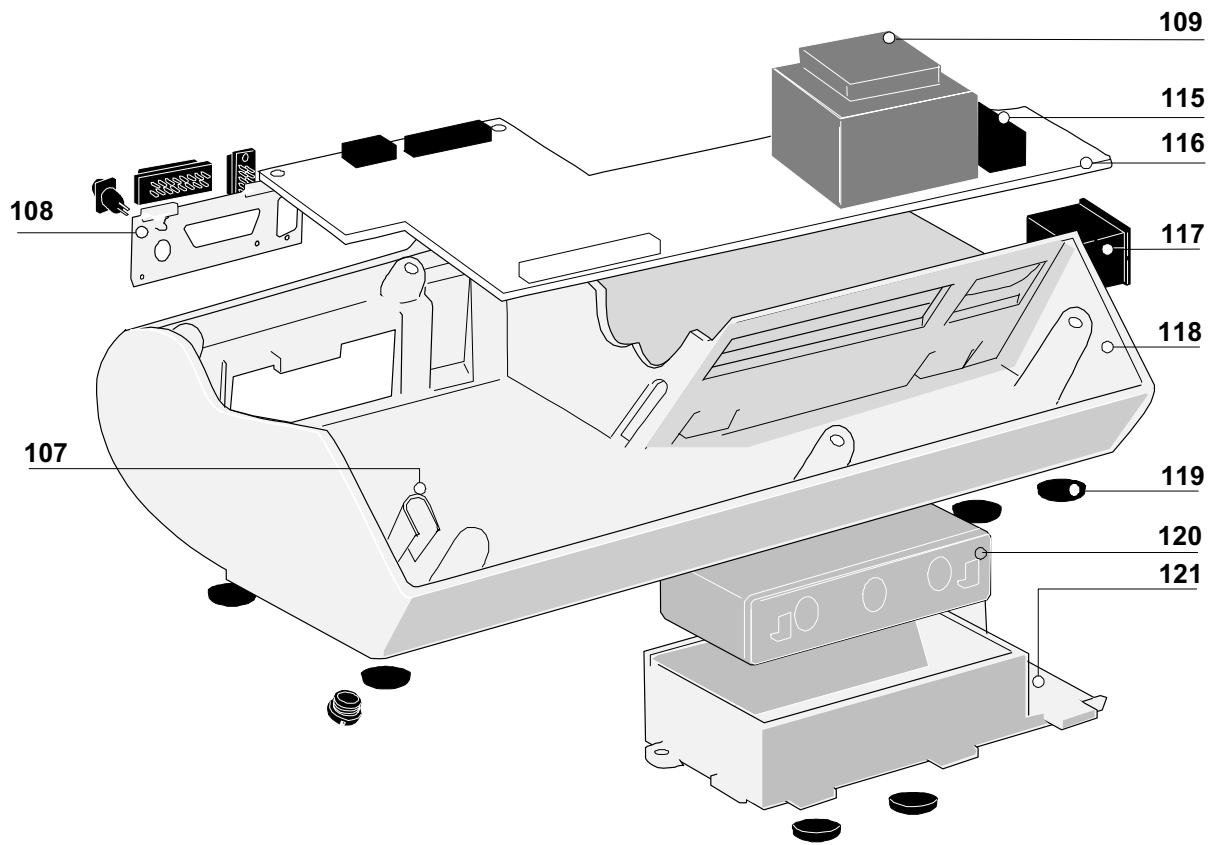

Mark	Qty	Reference	Name
120	1	174019	A500 6V 1.3Ah battery
121	1	199169	Pilot battery holder kit

8.3 Plunger unit

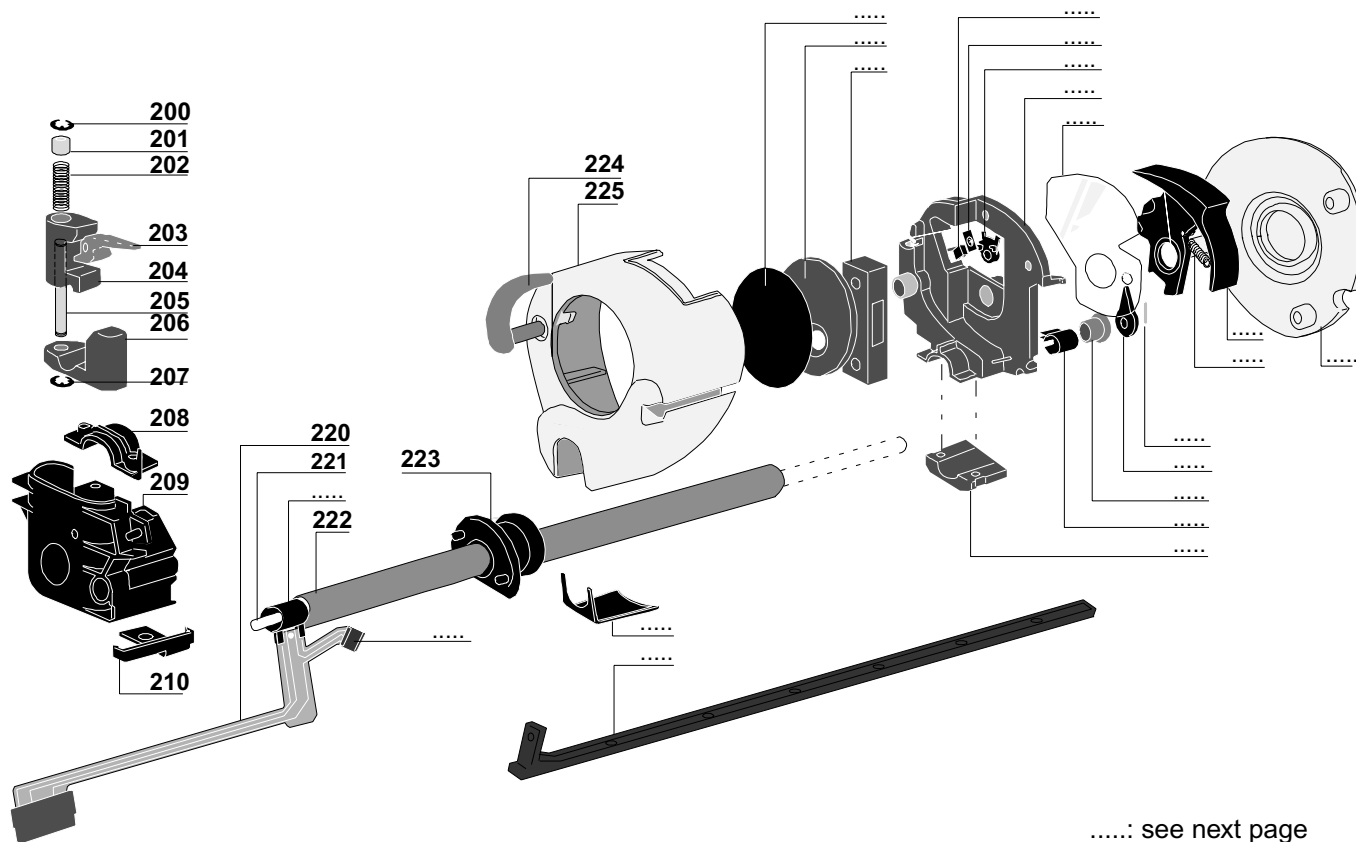

.....: see next page

Mark	Qty	Reference	Name
	1	167264	Anti-siphon spring
200/207	2	167360	3.5mm diam retaining ring
201	1	167465	Disengagement spring follower
202	1	167469	Disengagement follower
203	1	167460	Injected disengagement cam
204	1	167471	Injected upper mechanism nut
205	1	167464	Disengagement spring shaft
206	1	167472	Injected lower mechanism nut
208	1	167475	Mechanical flange
209	1	167281	Injected slug + mechanical block
210	1	167275	Flexible PCB clip
220	1	167271	Flex circuit
221	1	167317	Full disengagement shaft
222	1	167292	12 diam tube (20/60 ml version)
223	1	167403	Slotted injected input bearing
	1	177203	O-ring (to put in the bearing)
	1	177204	Stainless steel plate (to be mounted between the bearing and the end shield)
224	1	167291	Pilot anti-siphon arm
225	1	199253	Plunger kit Pilot C

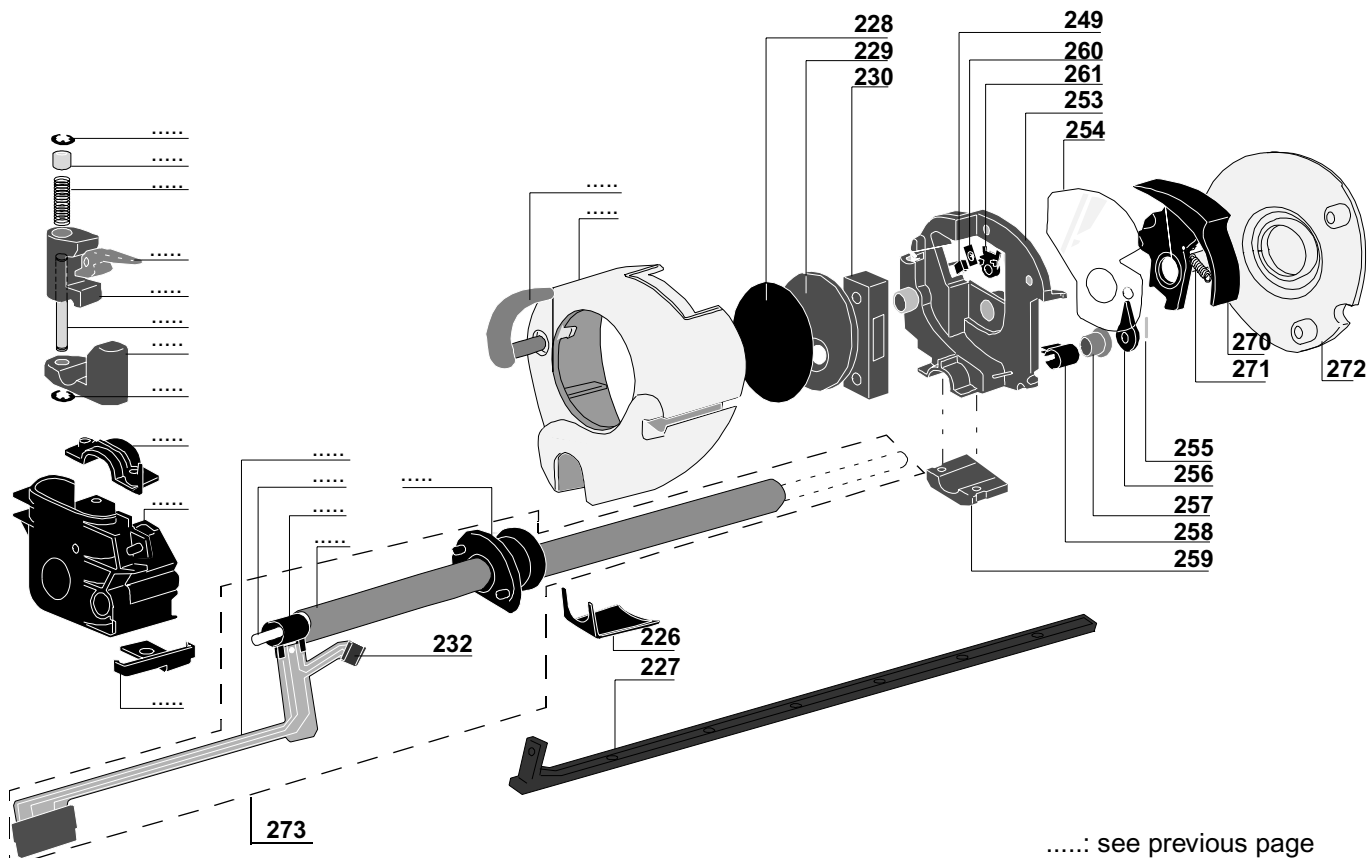

.....: see previous page

Mark	Qty	Reference	Name
226	1	167259	Plunger cover clip
227	1	167442	Injected M 0.5 rack
228	1	167721	36 diam protective label
229	1	167219	Inj C contact plate
230	1	167132	Force sensor.
232	1	173408	OMRON micro-switch
249	1	162311	Photo switch (type RP I 131)
253	1	167288	Reduced play C D plunger support
254	1	167497	Protective plunger film
255	1	167460	Disengagement cam
256	1	168231	Disengagement finger
257	1	167487	Sintered disengagement shaft bearing
258	2	167298	Injected flexible PCB protector
259	1	167272	Injected clamping collar
260	1	190714	Retaining ring
261	1	167385	Anti-siphon cam
270	1	167260	Disengagement lever
271	1	167245	Disengagement lever spring
272	1	167056	PILOT C plunger end shield
273	1	199103	Flexible circuit + tube kit

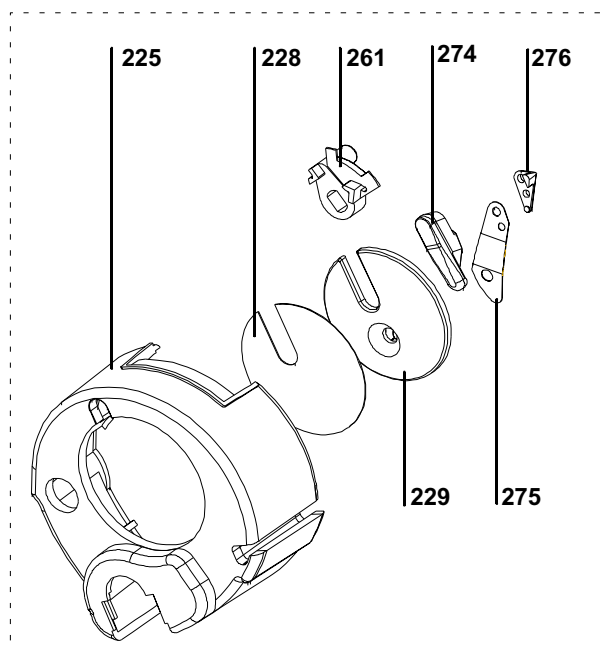
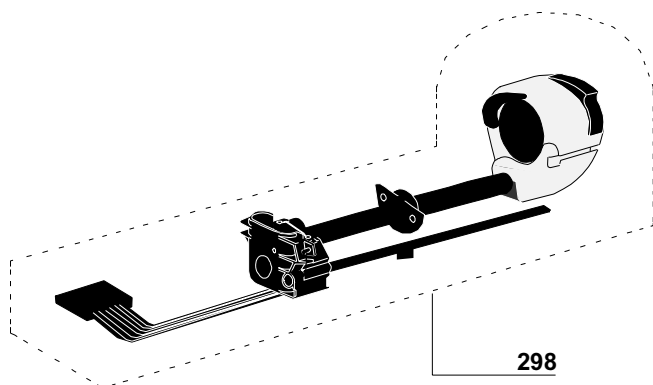

Plunger kit

Mark	Qty	Reference	Name	
225	1		Pilot plunger cover	
228	1		36 diam protective label	
229			Contact plate	
229	1		Inj C contact plate	Included in the plunger 298 kit ref. 199253
261	1		Anti-siphon cam	
274	1		Pil plunger removable bumper	
275	1		Pil plunger spring leaf	
276	1		Plate b	
298	1	199136	Mechanical kit	

8.4 Mechanical gear box

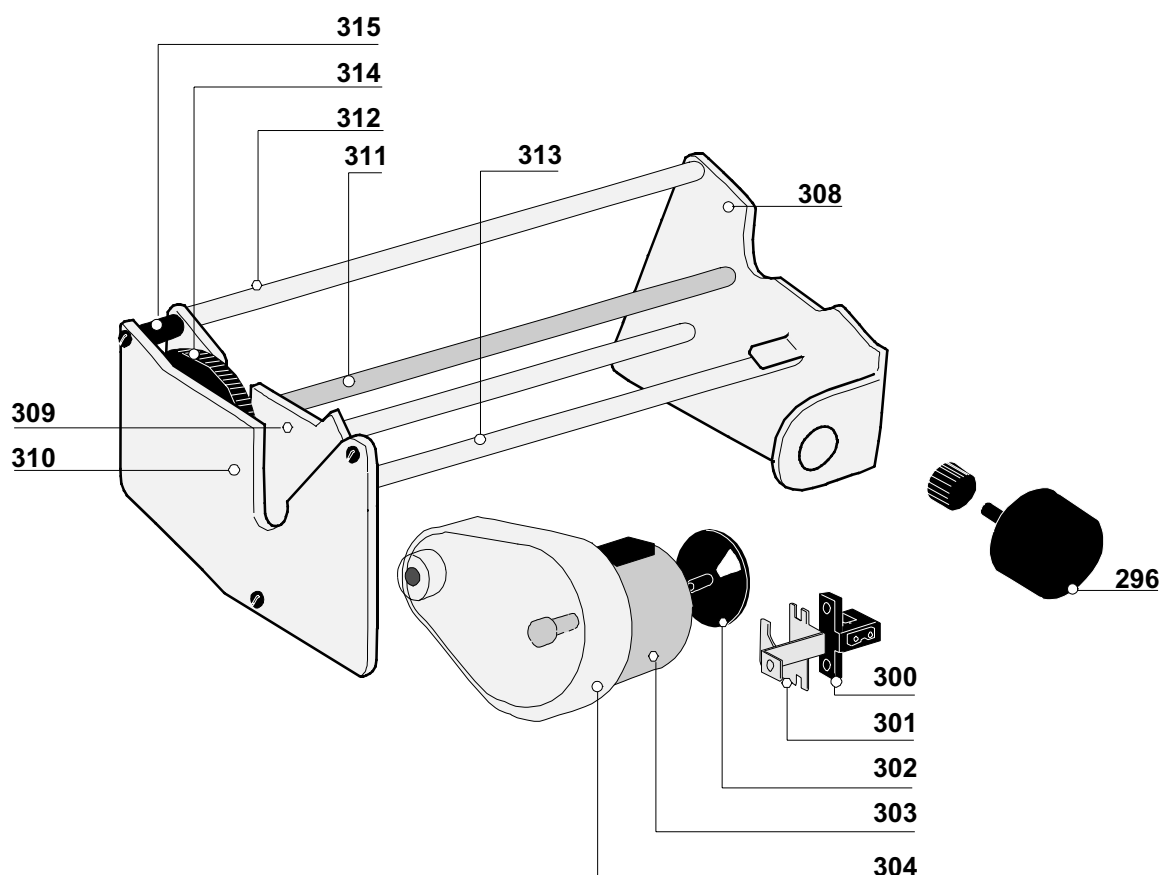

Mark	Qty	Reference	Name
	2	190714	Retaining ring
296	1	167963	HE13 wired potentiometer connector
300	1	167128	Motor rotation switch
301	1	167145	Standard motor opto support
302	1	167111	Motor rotation disk
300 to 304	1	167965	Motor / Reducer
304	1	167156	Reducer
308	1	167117	Mechanical end shield
309	1	167140	Intermediate end shield
310	1	167158	Standard reducer end shield
311	1	167142	T M6 2 x 100 threaded rod
312/313	3	167143	6 dia guide pin
314	1	167144	Pinion (64 teeth)
315	1	167157	Spacer

8.5 Labels

Mark	Qty	Reference	Name
	1	167838	Condensed instruction guide label FR/C
	1	167972	Condensed instruction guide label DIN
	1	167772	Condensed instruction guide label IS
	1	167829	Condensed instruction guide label NL
	1	167775	Condensed instruction guide label IT
	1	167857	Condensed instruction guide label SP
	1	167887	Condensed instruction guide label S
	1	167689	Condensed instruction guide label B, P
	1	167892	Door label FR/C, DIN, IS, NL, IT, SP, S, B, P
	1	167742	Buzzer adjustment label FR/C, DIN, IS, NL, IT, SP, S, B, P
	1	167741	Danger selection label FR/C
	1	167979	Danger selection label DIN
	1	167776	Danger selection label IS
	1	167811	Danger selection label NL
	1	167778	Danger selection label IT
	1	167858	Danger selection label SP
	1	167886	Danger selection label S
	1	167692	Danger selection label B, P
	1	167734	Battery door label FR/C, DIN, IS, S
	1	167756	Battery door label NL, IT, SP
	1	167691	Battery door label B, P
	1	171091	Main DANGER label (inside) FR/C, DIN, IS, NL, IT, SP, S, B, P
	1	167725	Danger mains label (outside) FR/C, IS
	1	167978	Danger mains label (outside) DIN
	1	167814	Danger mains label (outside) NL
	1	167800	Danger mains label (outside) IT
	1	167758	Danger mains label (outside) SP
	1	167897	Danger mains label (outside) S
	1	167690	Danger mains label (outside) B, P
	1	167721	Diam. 36 pusher label FR/C, DIN, IS, NL, IT, SP, S, B, P

Useful addresses

SALES DEPARTMENT

Fresenius Vial
Le Grand Chemin, 38590 Brézins

CUSTOMER SERVICE

Tel.: 00 33 (0) 4 76 67 10 81
or 00 33 (0) 4 76 67 10 54
or 00 33 (0) 4 76 67 11 08
Fax: 00 33 (0) 4 76 67 11 34

SALES MANAGEMENT

Tel.: 00 33 (0) 4 76 67 10 81
Fax: 00 33 (0) 4 76 67 11 34

TRAINING DEPARTMENT

Fresenius Vial
Le Grand Chemin, 38590 Brézins

Tel.: 04 76 67 10 76
Fax: 04 76 67 11 22

AFTER SALES SERVICE

FRANCE After Sales Service Division GRENOBLE Tel.: 04 76 67 10 34
Fresenius Vial Le Grand Chemin, 38590 Brézins Fax: 04 76 67 11 22
FRANCE

BELGIUM **FRESENIUS VIAL** NV/SA Tel.: 32/388.07307
Vial Médical Division Fax: 32/388.05007
Molenberglei 7
2627 Schelle
BELGIUM

GERMANY **FRESENIUS MCM**
AM-Neuen Berg
63749 ALZENAU
GERMANY

It is possible that this manual contains errors or typing mistakes.
Modifications may be made in future editions.
COPYRIGHT © 1998, **Fresenius Vial S.A.**

This document may not be reproduced in part or in whole without the written permission of
Fresenius Vial S.A.

Fresenius Vial S.A. - main office: Le Grand Chemin - 38590 Brézins (FRANCE)
Public Company with board of directors and advisory council, and with capital of 90128000F
SIREN Grenoble B 408 720 282.
Design and construction: SONOVISION ITEP